

# CM3566 Reference User Manual

---

V3. 20220326

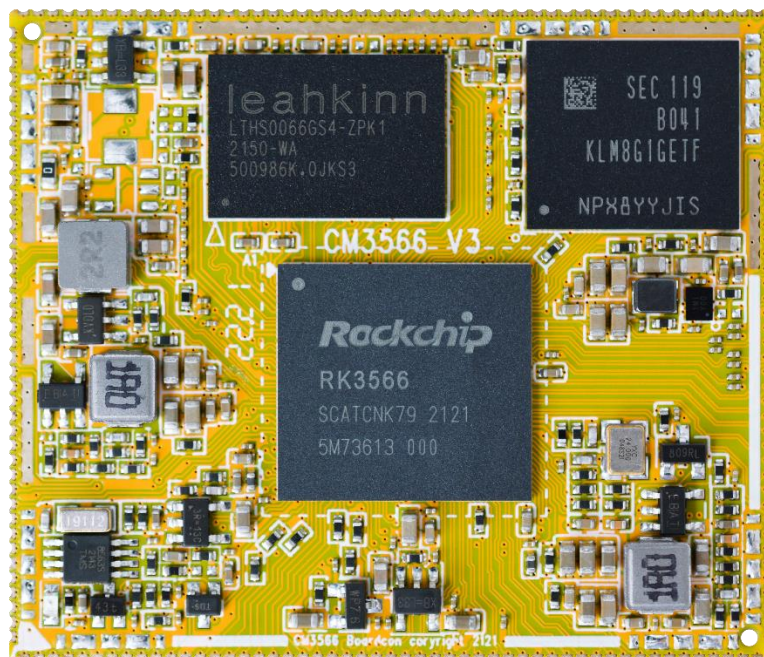

**Boardcon Embedded Design**

[www.armdesigner.com](http://www.armdesigner.com)



## **1. Introduction**

### **1.1. About this Manual**

This manual is intended to provide the user with an overview of the board and benefits, complete features specifications, and set up procedures. It contains important safety information as well.

### **1.2. Feedback and Update to this Manual**

To help our customers make the most of our products, we are continually making additional and updated resources available on the Boardcon website ([www.boardcon.com](http://www.boardcon.com) , [www.armdesigner.com](http://www.armdesigner.com)).

These include manuals, application notes, programming examples, and updated software and hardware. Check in periodically to see what's new!

When we are prioritizing work on these updated resources, feedback from customers is the number one influence, If you have questions, comments, or concerns about your product or project, please no hesitate to contact us at [support@armdesigner.com](mailto:support@armdesigner.com).

### **1.3. Limited Warranty**

Boardcon warrants this product to be free of defects in material and workmanship for a period of one year from date of buy. During this warranty period Boardcon will repair or replace the defective unit in accordance with the following process:

A copy of the original invoice must be included when returning the defective unit to Boardcon. This limited warranty does not cover damages resulting from lightning or other power surges, misuse, abuse, abnormal conditions of operation, or attempts to alter or modify the function of the product.

This warranty is limited to the repair or replacement of the defective unit. In no event shall Boardcon be liable or responsible for any loss or damages, including but not limited to any lost profits, incidental or consequential damages, loss of business, or anticipatory profits arising from the use or inability to use this product.

Repairs make after the expiration of the warranty period are subject to a repair charge and the cost of return shipping. Please contact Boardcon to arrange for any repair service and to obtain repair charge information.



## **Content**

1 CM3566 Introduction.....	3
1.1 Summary .....	3
1.2 Features.....	3
1.3 CM3566 Block Diagram .....	5
1.4 CM3566 specifications.....	6
1.5 CM3566 PCB Dimension .....	7
1.6 CM3566 Pin Definition .....	7
1.7 Development Kit (EM3566).....	14
2 Hardware Design Guide.....	15
2.1 Peripheral Circuit Reference.....	15
2.2 PCB Footprint .....	16
3 Product Electrical Characteristics .....	17
3.1 Dissipation and Temperature .....	17
3.2 Reliability of Test.....	17
3.3 Certifications .....	18



# 1 CM3566 Introduction

## 1.1 Summary

The CM3566 system-on-module is equipped with Rockchip's RK3566 with quad-core Cortex-A55 CPU, Mali-G52 GPU, and 1 TOPs NPU.

It is designed specifically for the AI devices such as industrial controller, IoT devices, intelligent interactive devices, personal computers and robots. The high performance and low power solution can help customers to introduce new technologies more quickly and enhance the overall solution efficiency.

## 1.2 Features

- **Microprocessor**
  - Quad-core Cortex-A55 up to 1.8G
  - 32KB I-cache and 32KB D-cache for each core, 512KB L3 cache
  - 1 TOPs Neural Process Unit
  - Mali-G52 up to 0.8G
- **Memory Organization**
  - LPDDR4 or LPDDR4X RAM up to 8GB
  - eMMC up to 128GB
- **Boot ROM**
  - Supports system code download through USB OTG or SD
- **Trust Execution Environment system**
  - Supports secure OTP and multiple cipher engine
- **Video Decoder/Encoder**
  - Supports video decoding up to 4K@50fps
  - Supports H.264 encode
  - H.264 HP encoding up to 1080p@100fps
  - Picture size up to 8192x8192
- **Display Subsystem**
  - **Video Output**
    - Supports HDMI 2.0 transmitter with HDCP 1.4/2.2, up to 4K@50fps
    - Supports 4 lanes MIPI DSI up to 2560x1440@60Hz
    - Or LVDS interface up to 1920x1080@60Hz
    - Supports ePD1.3 interface up to 2560x1600@60fps
    - Supports BT-656 8bit output
  - **Image in**
    - Supports up to 16bit DVP interface
    - Supports MIPI CSI 4lanes interface
    - Or 2ch MIPI CSI 2lanes interfaces
- **I2S/PCM/ AC97**
  - Four I2S/PCM interface



- Support Mic array Up to 8ch PDM/TDM interface
- One SPDIF output
- **USB and PCIE**
  - Three 2.0 USB interfaces
  - One USB 2.0 OTG, and two 2.0 USB hosts
  - One USB 3.0 host or SATA interface.
  - One 1lane PCIE or SATA interface.
- **Ethernet**
  - GMAC/EMAC
  - Support 10/100/1000Mbit/s data transfer rates
  - Support MII/RMII/RGMII PHY interface
- **I2C**
  - Up to Four I2C
  - Support standard mode and fast mode(up to 400kbit/s)
- **SDIO**
  - Support SDIO 3.0 protocol
- **SPI**
  - Up to four SPI controllers,
  - Full-duplex synchronous serial interface
- **UART**
  - Support up to 9 UARTs
  - UART2 with 2 wires for debug tools
  - Embedded two 64byte FIFO
  - Support auto flow control mode for UART1-5
- **SATA**
  - Two SATA host controller
  - Support SATA 1.5Gb/s, 3.0Gb/s and SATA 6.0Gb/s
- **ADC**
  - Up to Three ADC channels
  - 10-bit resolution
  - Voltage input range between 0V to 1.8V
  - Support up to 1MS/s sampling rate
- **PWM**
  - 14 on-chip PWMs with interrupt-based operation
  - Support 32bit time/counter facility
  - IR option on PWM3/7/11/15
- **Power unit**
  - Discrete Power on board
  - Single 3.3V input
  - Very low RTC consume current, less 5uA at 3V button Cell

# 1.3 CM3566 Block Diagram

## 1.3.1 RK3566 Block Diagram

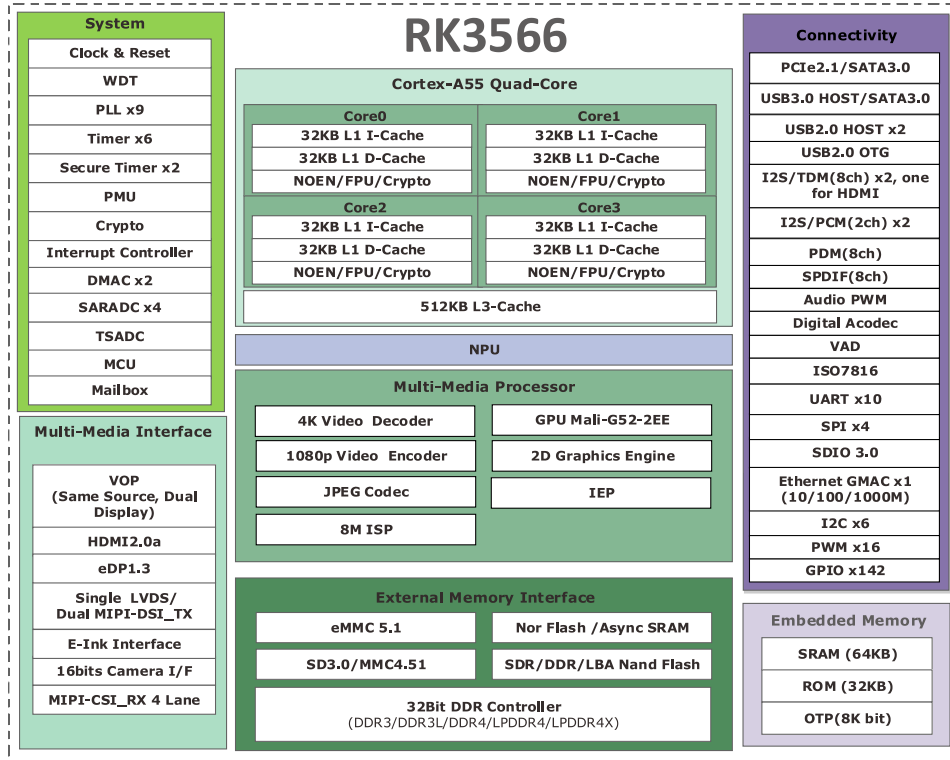

### 1.3.2 Development board (EM3566) Block Diagram

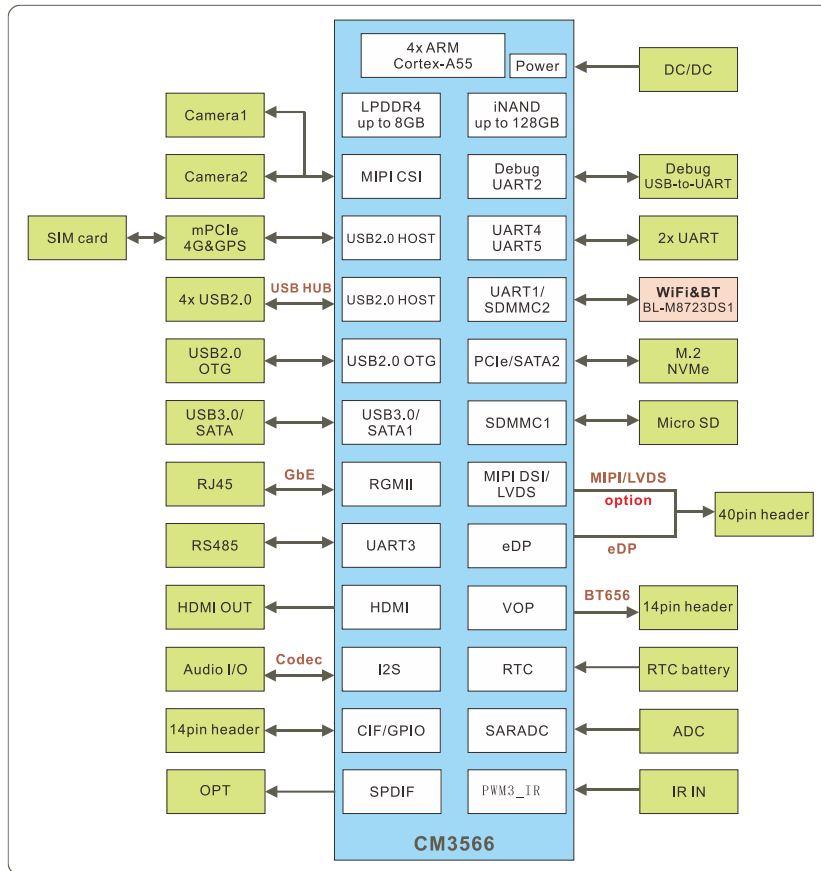

### 1.4 CM3566 specifications

Feature	Specifications
CPU	Quad-core Cortex-A55
DDR	2GB (up to 8GB)
eMMC FLASH	8GB (up to 128GB)
Power	DC 3.3V
LVDS/MIPI DSI	4-Lane
I2S	3-CH
MIPI CSI	4-Lane
SATA	2-CH
HDMI out	1-CH
Camera	1-CH(DVP) and 2-CH(CSI)
USB	2-CH (USB HOST2.0), 1-CH(OTG 2.0) and 1-CH(USB 3.0)
Ethernet	10/100/1000M MAC If MAC is not needed, it can be designed to 2x UART and 2x SPI.
SDMMC	2-CH



SPDIF TX	1-CH
I2C	4-CH
SPI	4-CH
UART	8-CH, 1-CH(DEBUG)
PWM	14-CH
ADC IN	3-CH
Board Dimension	40 x 47mm

## 1.5 CM3566 PCB Dimension

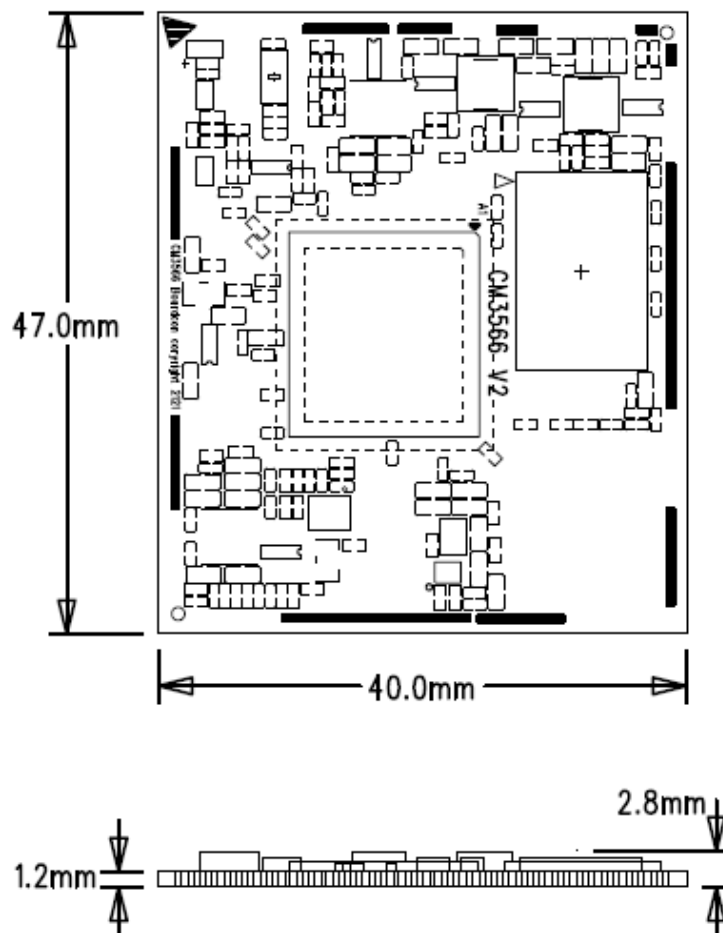

## 1.6 CM3566 Pin Definition

Pin	Signal	Description or functions	GPIO serial	IO Voltage
1	VCC3V3_SYS	3.3V Main Power input		3.3V
2	VCC3V3_SYS	3.3V Main Power input		3.3V
3	VCC3V3_SYS	3.3V Main Power input		3.3V
4	VCC_RTC	RTC button Cell Power input		3.0V





Pin	Signal	Description or functions	GPIO serial	IO Voltage
5	PMIC_32KOUT	32.768khz OD output(PU 10K)		3.3V
6	GND	Ground		0V
7	HDMITX_CEC_M0		GPIO4_D1_u	3.3V
8	HDMITX_SDA	Pull up 2.2K onboard	GPIO4_D0_u	3.3V
9	HDMITX_SCL	Pull up 2.2K onboard	GPIO4_C7_u	3.3V
10	GMAC1_RXER_M0	RMI receive error(V3 changed)	GPIO3_B4_d	3.3V
11	GMAC1_MCLKINO UT_M0	RGMII reference clock input(125Mhz)	GPIO3_C0_d	3.3V
12	GND	Ground		0V
13	GMAC1_TXD0_M0		GPIO3_B5_d	3.3V
14	GMAC1_TXD1_M0		GPIO3_B6_d	3.3V
15	GMAC1_TXEN_M0		GPIO3_B7_d	3.3V
16	GMAC1_RXDV_CR S_M0		GPIO3_B3_d	3.3V
17	GMAC1_RXD1_M0		GPIO3_B2_d	3.3V
18	GMAC1_RXD0_M0		GPIO3_B1_d	3.3V
19	GMAC1_RXD3_M0		GPIO3_A5_d	3.3V
20	GMAC1_RXD2_M0		GPIO3_A4_d	3.3V
21	GMAC1-RXCLK_M0		GPIO3_A7_d	3.3V
22	GMAC1_TXD2_M0		GPIO3_A2_d	3.3V
23	GMAC1_TXD3_M0		GPIO3_A3_d	3.3V
24	GMAC1_TXCLK_M 0		GPIO3_A6_d	3.3V
25	MIPI_DSI_TX0_D3 N/LVDS_TX0_D3N	MIPI DSI or LVDS TXD3N		1.8V
26	MIPI_DSI_TX0_D3P /LVDS_TX0_D3P	MIPI DSI or LVDS TXD3P		1.8V
27	MIPI_DSI_TX0_D2 N/LVDS_TX0_D2N	MIPI DSI or LVDS TXD2N		1.8V
28	MIPI_DSI_TX0_D2P /LVDS_TX0_D2P	MIPI DSI or LVDS TXD2P		1.8V
29	MIPI_DSI_TX0_D1 N/LVDS_TX0_D1N	MIPI DSI or LVDS TXD1N		1.8V
30	MIPI_DSI_TX0_D1P /LVDS_TX0_D1P	MIPI DSI or LVDS TXD1P		1.8V
31	MIPI_DSI_TX0_D0 N/LVDS_TX0_D0N	MIPI DSI or LVDS TXD1N		1.8V
32	MIPI_DSI_TX0_D0P /LVDS_TX0_D0P	MIPI DSI or LVDS TXD1P		1.8V
33	MIPI_DSI_TX0_CLK N/LVDS_TX0_CLKN	MIPI DSI or LVDS TXD1N		1.8V
34	MIPI_DSI_TX0_CLK	MIPI DSI or LVDS TXD1P		1.8V



Pin	Signal	Description or functions	GPIO serial	IO Voltage
	P/LVDS_TX0_CLKP			
35	HDMI_TX_HPDIN	HDMI HPD input		3.3V
36	HDMI_TXCLKN			1.8V
37	HDMI_TXCLKP			1.8V
38	HDMI_TX0N			1.8V
39	HDMI_TX0P			1.8V
40	HDMI_TX1N			1.8V
41	HDMI_TX1P			1.8V
42	HDMI_TX2N			1.8V
43	HDMI_TX2P			1.8V
44	MIPI_CSI_RX_CLK 1N	MIPI CSI1 CLKN		1.8V
45	MIPI_CSI_RX_CLK 1P	MIPI CSI1 CLKP		1.8V
46	MIPI_CSI_RX_D3N	CSI0 RXD3N or CSI1 RXD1N		1.8V
47	MIPI_CSI_RX_D3P	CSI0 RXD3P or CSI1 RXD1P		1.8V
48	MIPI_CSI_RX_D2N	CSI0 RXD2N or CSI1 RXD0N		1.8V
49	MIPI_CSI_RX_D2P	CSI0 RXD2P or CSI1 RXD0P		1.8V
50	MIPI_CSI_RX_D1P	CSI0 RXD1P		1.8V
51	MIPI_CSI_RX_D1N	CSI0 RXD1N		1.8V
52	MIPI_CSI_RX_D0N	CSI0 RXD0N		1.8V
53	MIPI_CSI_RX_D0P	CSI0 RXD0P		1.8V
54	MIPI_CSI_RX_CLK 0N	MIPI CSI0 CLKN		1.8V
55	MIPI_CSI_RX_CLK 0P	MIPI CSI0 CLKP		1.8V
56	GND	Ground		0V
57	PWM5		GPIO0_C4_d	3.3V
58	LCD_BL_PWM	PWM4	GPIO0_C3_d	3.3V
59	PWM3_IR		GPIO0_C2_d	3.3V
60	PCIE20_SATA2_RX P	PCIE or SATA2 RXP		1.8V
61	PCIE20_SATA2_RX N	PCIE or SATA2 RXN		1.8V
62	PCIE20_SATA2_TX N	PCIE or SATA2 TXN		1.8V
63	PCIE20_SATA2_TX P	PCIE or SATA2 TXP		1.8V
64	PCIE20_REFCLKP			1.8V
65	PCIE20_REFCLKN			1.8V
66	USB3_HOST1_SST XP	USB3.0 or SATA1 TXP		1.8V



Pin	Signal	Description or functions	GPIO serial	IO Voltage
67	USB3_HOST1_SST XN	USB3.0 or SATA1 TXN		1.8V
68	USB3_HOST1_SSR XP	USB3.0 or SATA1 RXN		1.8V
69	USB3_HOST1_SSR XN	USB3.0 or SATA1 RXP		1.8V
70	USB_OTG0_DM			1.8V
71	USB_OTG0_DP			1.8V
72	USB3_HOST1_DP			1.8V
73	USB3_HOST1_DM			1.8V
74	EDP_TX_D2N			1.8V
75	EDP_TX_D2P			1.8V
76	EDP_TX_D1N			1.8V
77	EDP_TX_D1P			1.8V
78	EDP_TX_D0N			1.8V
79	EDP_TX_D0P			1.8V
80	EDP_TX_D3N			1.8V
81	EDP_TX_D3P			1.8V
82	EDP_TX_AUXN			1.8V
83	EDP_TX_AUXP			1.8V
84	SDMMC0_DET_L		GPIO0_A4_u	3.3V
85	SDMMC0_CLK	UART5_TX_M0	GPIO2_A2_d	3.3V
86	GND	Ground		0V
87	SDMMC0_CMD	UART5_RX_M0	GPIO2_A1_u	3.3V
88	SDMMC0_D3	UART5_RTSn_M0	GPIO2_A0_u	3.3V
89	SDMMC0_D2	UART5_CTSn_M0	GPIO1_D7_u	3.3V
90	SDMMC0_D1	UART6_RX_M1	GPIO1_D6_u	3.3V
91	SDMMC0_D0	UART6_TX_M1	GPIO1_D5_u	3.3V
92	USB_OTG0_ID			3.3V
93	USB_OTG0_VBUS DET	USB OTG VBUS input		3.3V
94	UART1_RX_M0		GPIO2_B3_u	1.8V
95	UART1_TX_M0		GPIO2_B4_u	1.8V
96	UART1_RTSn_M0		GPIO2_B5_u	1.8V
97	UART1_CTSn_M0		GPIO2_B6_u	1.8V
98	<u>BT_REG_ON_H</u>	I2S2_SCLK_RX_M0	GPIO2_B7_d	1.8V
99	BT_WAKE_HOST_ H	I2S2_LRCLK_RX_M0	GPIO2_C0_d	1.8V
100	HOST_WAKE_BT_ H	I2S2_MCLK_M0	GPIO2_C1_d	1.8V
101	<u>WIFI_WAKE_HOST</u> <u>H</u>	I2C4_SCL_M1	GPIO2_B2_d	1.8V



Pin	Signal	Description or functions	GPIO serial	IO Voltage
102	<u>WIFI_REG_ON_H</u>	UART8_RX_M0	GPIO2_C6_d	1.8V
103	I2S2_SCLK_TX_M0	SPI2_MISO_M0	GPIO2_C2_d	1.8V
104	I2S2_LRCK_TX_M0	SPI2_MOSI_M0	GPIO2_C3_d	1.8V
105	I2S2_SDO_M0	SPI2_CS0_M0	GPIO2_C4_d	1.8V
106	I2S2_SDI_M0	UART8_TX_M0	GPIO2_C5_d	1.8V
107	SDMMC1_D3	UART7_TX_M0	GPIO2_A6_u	1.8V
108	SDMMC1_D2	UART7_RX_M0	GPIO2_A5_u	1.8V
109	SDMMC1_D1	UART6_TX_M0	GPIO2_A4_u	1.8V
110	SDMMC1_D0	UART6_RX_M0	GPIO2_A3_u	1.8V
111	SDMMC1_CMD	UART9_RX_M0	GPIO2_A7_u	1.8V
112	SDMMC1_CLK	UART9_TX_M0	GPIO2_B0_d	1.8V
113	GND	Ground		0V
114	SARADC_VIN3			1.8V
115	SARADC_VIN2_HP_HOOK			1.8V
116	SARADC_VIN0_KEY/RECOVERY	Pull up 10K onboard		1.8V
117	GND	Ground		0V
118	PCIE20_PERSTn_M2	PDM_SDI1_M0	GPIO1_B2_d	3.3V
119	PCIE20_WAKEn_M2	PDM_SDI2_M0	GPIO1_B1_d	3.3V
120	PCIE20_CLKREqn_M2	PDM_SDI3_M0	GPIO1_B0_d	3.3V
121	UART3_RX_M0	AudioPWM_LOUT_P/I2C3_SDA_M0	GPIO1_A0_u	3.3V
122	UART3_TX_M0	AudioPWM_LOUT_N/I2C3_SCL_M0	GPIO1_A1_u	3.3V
123	UART4_RX_M0	PDM_CLK1_M0/SPDIF_TX_M0	GPIO1_A4_d	3.3V
124	UART4_TX_M0	AudioPWM_ROUT_P/PDM_CLK0_M0	GPIO1_A6_d	3.3V
125	I2S1_LRCK_TX_M0_PMIC		GPIO1_A5_d	3.3V
126	I2S1_SDI0_M0/PDM_SDI0_M0_PMIC	PDM_SDI0_M0	GPIO1_B3_d	3.3V
127	I2S1_SCLK_TX_M0_PMIC	UART3_CTSn_M0	GPIO1_A3_d	3.3V
128	I2S1_SDO0_M0_PMIC	AudioPWM_ROUT_N/UART4_CTSn_M0	GPIO1_A7_d	3.3V
129	I2S1_MCLK_M0_PMIC	UART3_RTsn_M0	GPIO1_A2_d	3.3V
130	GND	Ground		0V



Pin	Signal	Description or functions	GPIO serial	IO Voltage
131	SPI0_CS0_M0	PWM7	GPIO0_C6_d	3.3V
132	SPI0_MISO_M0	PWM6	GPIO0_C5_d	3.3V
133	SPI0_MOSI_M0	I2C2_SDA_M0	GPIO0_B6_u	3.3V
134	SPI0_CLK_M0	I2C2_SCL_M0	GPIO0_B5_u	3.3V
135	SPI3_CS0_M1	I2S3_SDI_M1	GPIO4_C6_d	3.3V
136	SPI3_MISO_M1	I2S3_SDO_M1	GPIO4_C5_d	3.3V
137	SPI3_MOSI_M1	I2S3_SCLK_M1	GPIO4_C3_d	3.3V
138	SPI3_CLK_M1	I2S3_MCLK_M1	GPIO4_C2_d	3.3V
139	LCD_PWREN_H		GPIO0_C7_d	3.3V
140	PWM0_M0		GPIO0_B7_d	3.3V
141	UART5_RX_M1		GPIO3_C3_d	3.3V
142	UART5_TX_M1		GPIO3_C2_d	3.3V
143	UART2DBG_RX	UART2 for Debug	GPIO0_D0_u	3.3V
144	UART2DBG_TX	UART2 for Debug	GPIO0_D1_u	3.3V
145	SPDIF_TX_M2	I2S3_LRCK_M1/EDP_HPDI M0	GPIO4_C4_d	3.3V
146	GPIO0_A6_d			3.3V
147	GPIO0_A3_u			3.3V
148	GPIO0_A0_d			3.3V
149	CAMERAF_RST_L	CAM_CLKOUT1	GPIO4_B0_d	1.8V
150	CAMERAB_RST_L		GPIO4_B1_d	1.8V
151	<u>CIF_8BIT_D7</u>	CIF_D15	GPIO4_A5_d	1.8V
152	<u>CIF_8BIT_D6</u>	CIF_D14	GPIO4_A4_d	1.8V
153	<u>CIF_8BIT_D5</u>	CIF_D13	GPIO4_A3_d	1.8V
154	<u>CIF_8BIT_D4</u>	CIF_D12	GPIO4_A2_d	1.8V
155	<u>CIF_8BIT_D3</u>	CIF_D11	GPIO4_A1_d	1.8V
156	<u>CIF_8BIT_D2</u>	CIF_D10	GPIO4_A0_d	1.8V
157	<u>CIF_8BIT_D1</u>	CIF_D9	GPIO3_D7_d	1.8V
158	<u>CIF_8BIT_D0</u>	CIF_D8	GPIO3_D6_d	1.8V
159	GND	Ground		0V
160	USB2_HOST2_DM	HOST2_DM		1.8V
161	USB2_HOST2_DP	HOST2_DP		1.8V
162	USB2_HOST3_DP	HOST3_DP		1.8V
163	USB2_HOST3_DM	HOST3_DM		1.8V
164	<u>CIF_8BIT_VSYNC</u>		GPIO4_B7_d	1.8V
165	<u>CIF_8BIT_HREF</u>		GPIO4_B6_d	1.8V
166	<u>CIF_8BIT_CLKIN</u>		GPIO4_C1_d	1.8V
167	GND	Ground		0V
168	CIF_CLKOUT		GPIO4_C0_d	1.8V
169	VOP-BT656_D7_M1	CIF_D7	GPIO3_D5_d	1.8V
170	VOP-BT656_D6_M1	CIF_D6	GPIO3_D4_d	1.8V
171	VOP-BT656_D5_M1	CIF_D5	GPIO3_D3_d	1.8V



Pin	Signal	Description or functions	GPIO serial	IO Voltage
172	VOP-BT656_D4_M1	CIF_D4	GPIO3_D2_d	1.8V
173	VOP-BT656_D3_M1	CIF_D3	GPIO3_D1_d	1.8V
174	VOP-BT656_D2_M1	CIF_D2	GPIO3_D0_d	1.8V
175	VOP-BT656_D1_M1	CIF_D1	GPIO3_C7_d	1.8V
176	VOP-BT656_D0_M1	CIF_D0	GPIO3_C6_d	1.8V
177	VOP_BT656_CLK_M1		GPIO4_B4_d	1.8V
178	GPIO4_B5_d_1V8			1.8V
179	I2C4_SDA_M0_1V8	Pull up 2.2K onboard	GPIO4_B2_d	1.8V
180	I2C4_SCL_M0_1V8	Pull up 2.2K onboard	GPIO4_B3_d	1.8V
181	GND	Ground		0V
182	I2C1_SDA	Pull up 2.2K onboard	GPIO0_B4_u	3.3V
183	I2C1_SCL	Pull up 2.2K onboard	GPIO0_B3_u	3.3V
184	GPIO0_A5_d	PCIE20_CLKREQn_M0		3.3V
185	GMAC1_MDIO_M0		GPIO3_C5_d	3.3V
186	GMAC1_MDC_M0		GPIO3_C4_d	3.3V

**Note:**  
*I2C1 can't be used for exclusive bus, Such as CTP.  
RGMII default is 3.3V IO, but can change to 1.8V.*

## 1.7 Development Kit (EM3566)

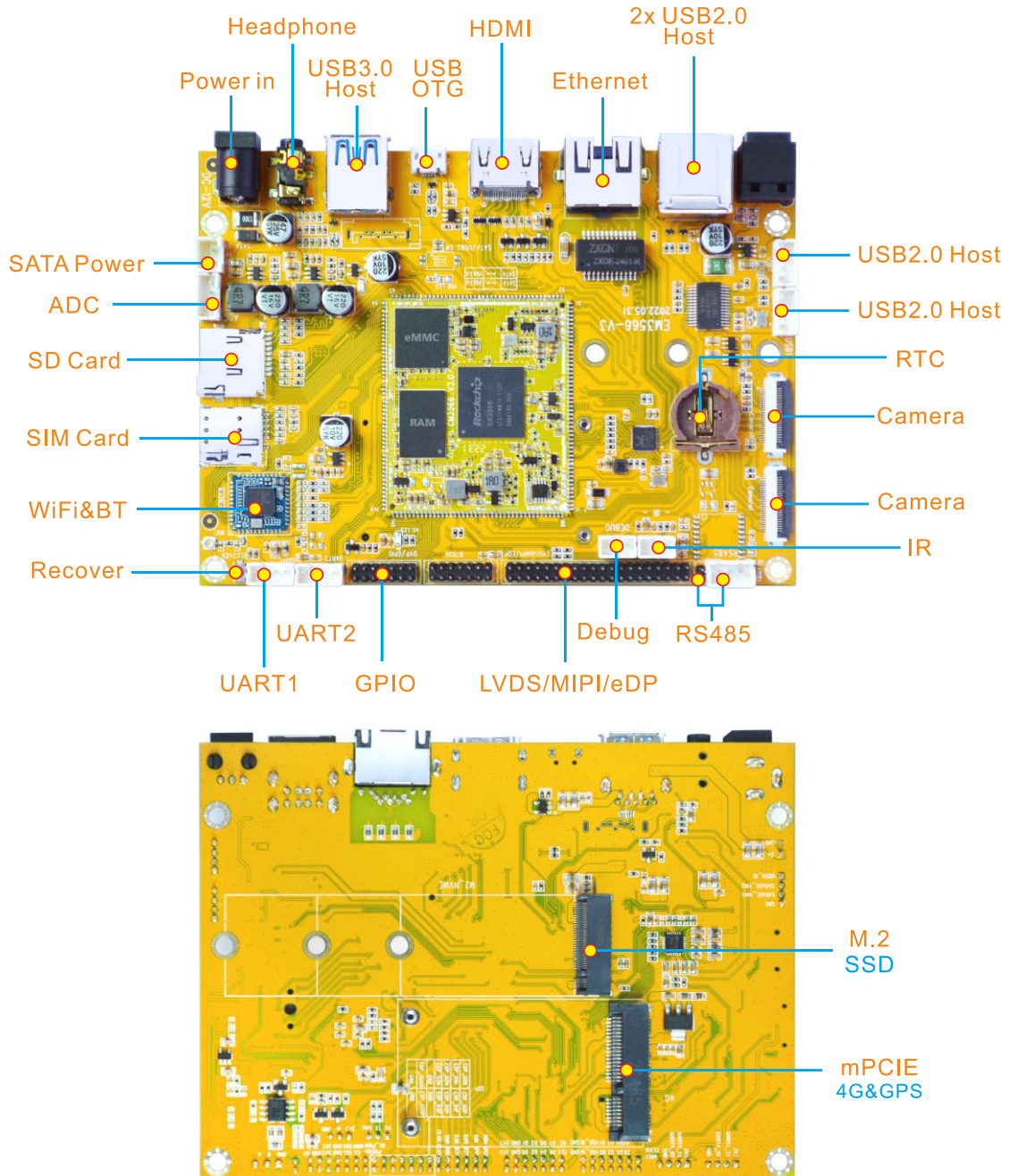



# 2 Hardware Design Guide

## 2.1 Peripheral Circuit Reference

### 2.1.1 External Power

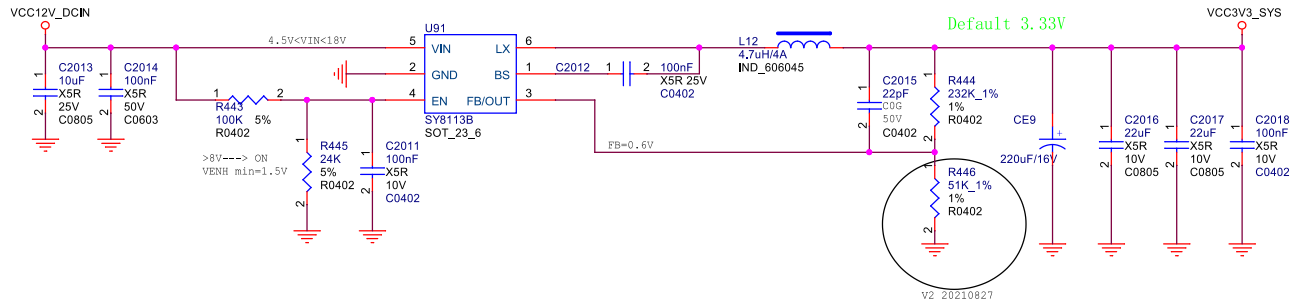
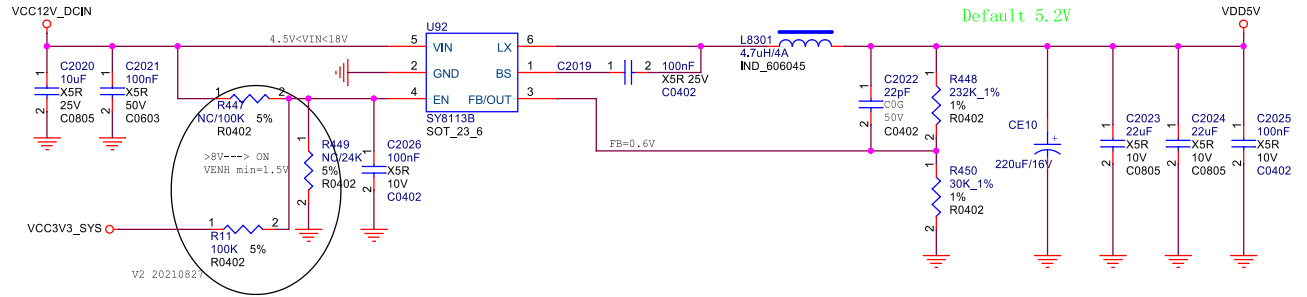

$$V_{out} = 0.6 * (1 + R444/R446)$$

### 2.1.2 Debug Circuit

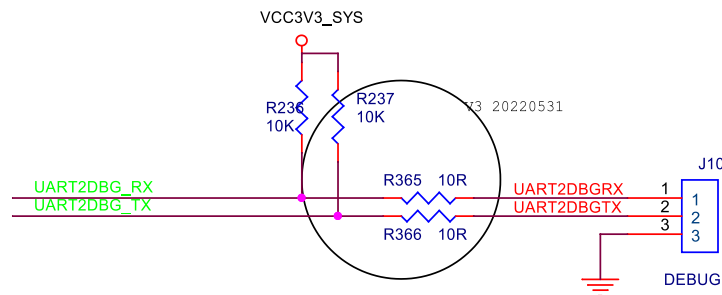





### 2.1.3 USB OTG Interface Circuit

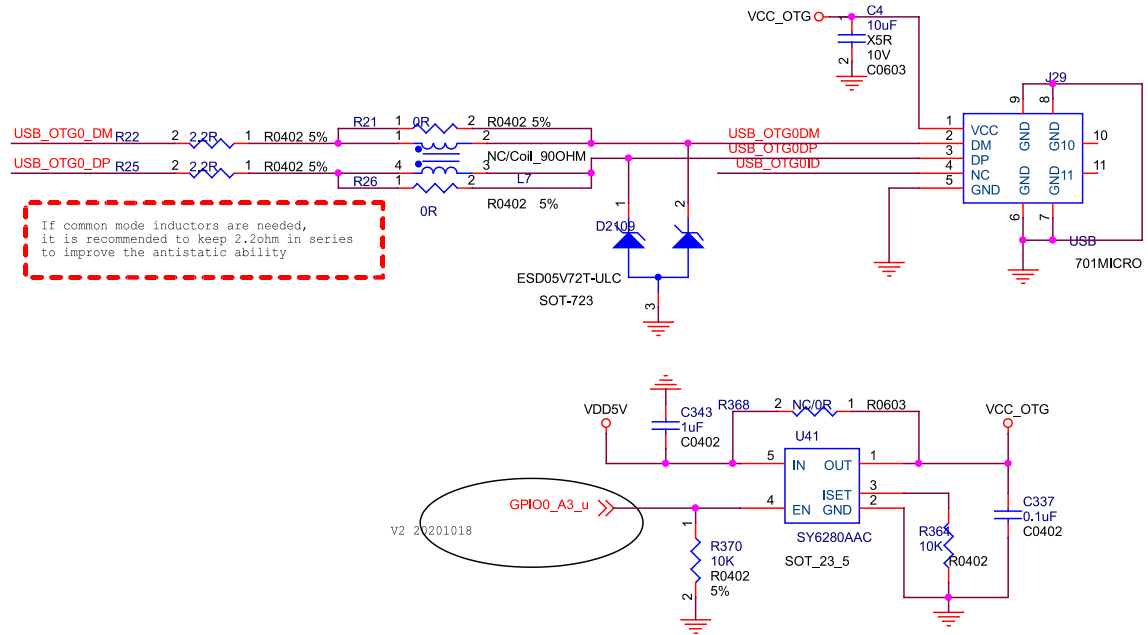

### 2.2 PCB Footprint

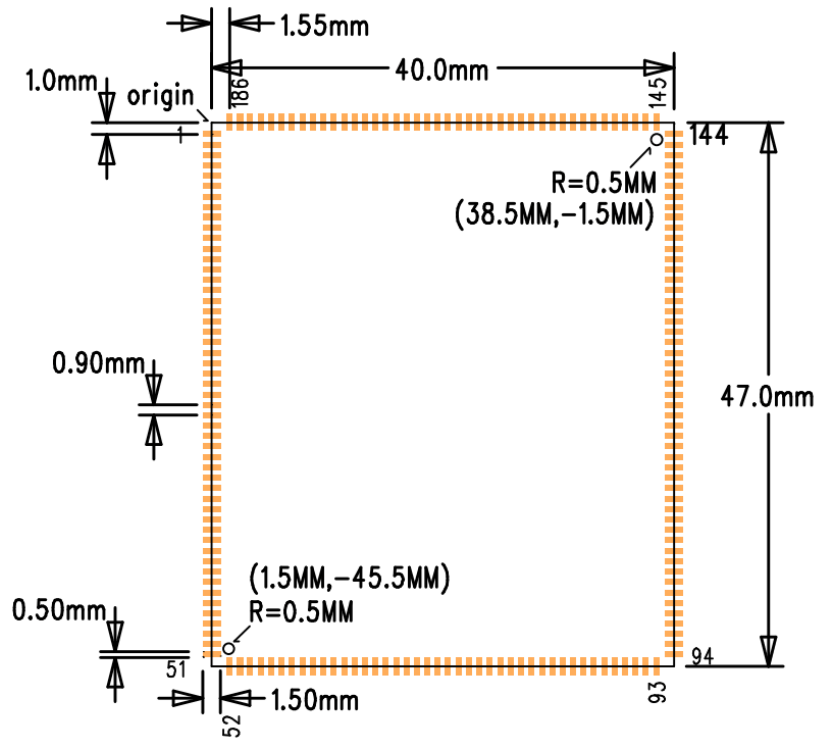



## 3 Product Electrical Characteristics

### 3.1 Dissipation and Temperature

Symbol	Parameter	Min	Typ	Max	Unit
VCC3V3_SYS	System IO Voltage	3.3-5%	3.3	3.3+5%	V
I <sub>sys_in</sub>	VCC3V3_SYS input Current		1200		mA
VCC_RTC	RTC Voltage	1.8	3	3.4	V
Symbol	Parameter	Min	Typ	Max	Unit
I <sub>rtc</sub>	RTC input Current		5	8	uA
T <sub>a</sub>	Operating Temperature	-0		70	°C
T <sub>stg</sub>	Storage Temperature	-40		85	°C

### 3.2 Reliability of Test

Low Temperature Operating Test		
Contents	Operating 4h in Low temperature	-20°C±2°C
Result	pass	
High Temperature Operating Test		
Contents	Operating 8h in high temperature	65°C±2°C
Result	pass	
Operating Life Test		
Contents	Operating in room	120h
Result	pass	



### 3.3 Certifications



## Certificate of Conformity

NO.: ENS2112140001E00101C

The following product has been tested by us with the listed standards and found in conformity with the council EMC directive 2014/30/EU. This is to certify that the specimen is in conformity with the assessment requirement mentioned follow. This certificate does not imply assessment to the production of the product.

Applicant	: BOARDCON TECHNOLOGY LIMITED
Address	: ROOM702, XINAN BUSINESS BUILDING, 45ZONE, BAOAN DISTRCT
Manufacturer	: BOARDCON TECHNOLOGY LIMITED
Address	: ROOM702, XINAN BUSINESS BUILDING, 45ZONE, BAOAN DISTRCT
Trade Mark	: N/A
EUT	: CM3566 Core Board
M/N	: CM3566-V2
Test Standards	: EN 55032: 2015+A11:2020 EN IEC 61000-3-2: 2019 EN 61000-3-3: 2013+A1: 2019 EN 55035:2017+A11:2020
Version	: Ver.1.0

  
  
 (Manager)  
 December 20, 2021

The certificate is based on a single evaluation of one sample of above-mentioned products, It does not imply an assessment of the whole production and does not permit the use of the test lab. logo .

---

EMTEK (Shenzhen) Co., Ltd.  
 Add: Building 69, Majialong Industry Zone, Nanshan District, Shenzhen, Guangdong, China [Http://www.emtek.com.cn](http://www.emtek.com.cn) E-mail: [cs.rep@emtek.com.cn](mailto:cs.rep@emtek.com.cn)

