

CM3568 Reference User Manual

V2. 202309

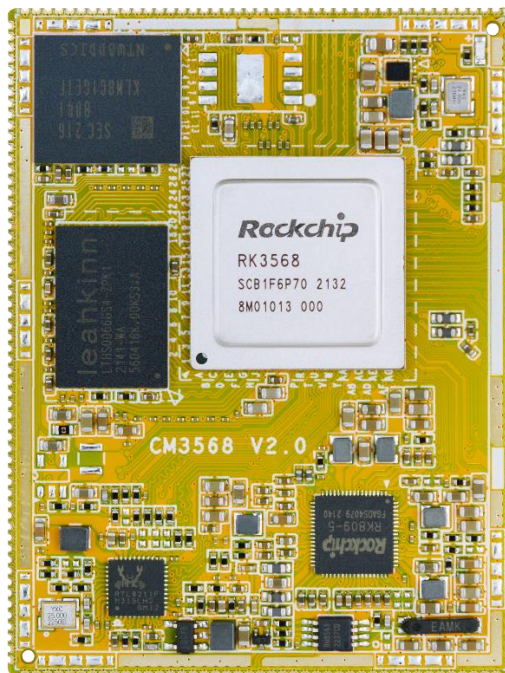

Boardcon Embedded Design

www.armdesigner.com

1. Introduction

1.1. About this Manual

This manual is intended to provide the user with an overview of the board and benefits, complete features specifications, and set up procedures. It contains important safety information as well.

1.2. Feedback and Update to this Manual

To help our customers make the most of our products, we are continually making additional and updated resources available on the Boardcon website (www.boardcon.com , www.armdesigner.com).

These include manuals, application notes, programming examples, and updated software and hardware. Check in periodically to see what's new!

When we are prioritizing work on these updated resources, feedback from customers is the number one influence, If you have questions, comments, or concerns about your product or project, please no hesitate to contact us at support@armdesigner.com.

1.3. Limited Warranty

Boardcon warrants this product to be free of defects in material and workmanship for a period of one year from date of buy. During this warranty period Boardcon will repair or replace the defective unit in accordance with the following process:

A copy of the original invoice must be included when returning the defective unit to Boardcon. This limited warranty does not cover damages resulting from lightning or other power surges, misuse, abuse, abnormal conditions of operation, or attempts to alter or modify the function of the product.

This warranty is limited to the repair or replacement of the defective unit. In no event shall Boardcon be liable or responsible for any loss or damages, including but not limited to any lost profits, incidental or consequential damages, loss of business, or anticipatory profits arising from the use or inability to use this product.

Repairs make after the expiration of the warranty period are subject to a repair charge and the cost of return shipping. Please contact Boardcon to arrange for any repair service and to obtain repair charge information.



Content

1 CM3568 Introduction.....	3
1.1 Summary	3
1.2 Features.....	3
1.3 CM3568 Block Diagram	5
1.4 CM3568 specifications.....	6
1.5 CM3568 PCB Dimension	7
1.6 CM3568 Pin Definition	7
1.7 Development Kit (EM3568).....	14
2 Hardware Design Guide.....	15
2.1 Peripheral Circuit Reference	15
2.2 PCB Footprint	16
3 Product Electrical Characteristics	17
3.1 Dissipation and Temperature	17
3.2 Reliability of Test.....	17

1 CM3568 Introduction

1.1 Summary

The CM3568 system-on-module is equipped with Rockchip's RK3568 with quad-core Cortex-A55 CPU, Mali-G52 GPU, and 1 TOPs NPU.

It is designed specifically for the AI devices such as industrial controller, IoT devices, intelligent interactive devices, personal computers and robots. The high performance and low power solution can help customers to introduce new technologies more quickly and enhance the overall solution efficiency.

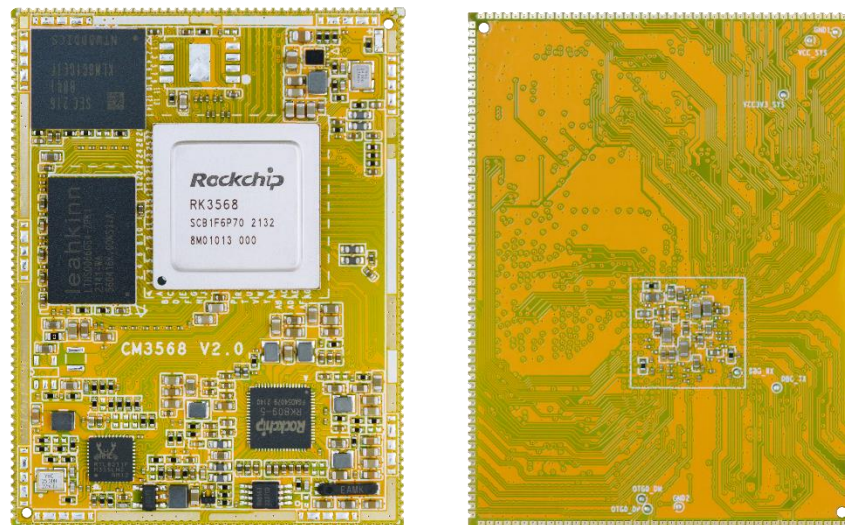

1.2 Features

- **Microprocessor**
 - Quad-core Cortex-A55 up to 1.8GHz
 - 32KB I-cache and 32KB D-cache for each core, 512KB L3 cache
 - 1 TOPs Neural Process Unit
 - Mali-G52 up to 0.8GHz
- **Memory Organization**
 - LPDDR4 or LPDDR4X RAM up to 8GB
 - EMMC up to 128GB
- **Boot ROM**
 - Supports system code download through USB OTG or SD
- **Trust Execution Environment system**
 - Supports secure OTP and multiple cipher engine
- **Video Decoder/Encoder**
 - Supports video decoding up to 4K@60fps
 - Supports H.264 encode
 - H.264 HP encoding up to 1080p@100fps



- Picture size up to 8192x8192
- **Display Subsystem**
 - **Video Output**

Supports HDMI 2.0 transmitter with HDCP 1.4/2.2, up to 4K@60fps

Supports 8/4 lanes MIPI DSI up to 2560x1440@60Hz

Or LVDS interface up to 1920x1080@60Hz

Supports ePD1.3 interface up to 2560x1600@60fps

Supports BT-656 8bit output

Supports BT-1120 16bit output

Support 24bits RGB TTL output

Support three display with different source
 - **Image Input**

Supports MIPI CSI 4lanes interface

Or 2ch MIPI CSI 2lanes interfaces
- **I2S/PCM/ AC97**
 - Three I2S/PCM interfaces
 - Support Mic array Up to 8ch PDM/TDM interface
 - One SPDIF output
- **USB and PCIE**
 - Three 2.0 USB interfaces
 - One USB 2.0 OTG+SATA or 3.0 USB hosts
 - One USB 3.0 host or SATA interface.
 - One 1lane PCIE or SATAI interface.
- **Ethernet**
 - One GMAC/EMAC and QSGMII
 - Support 10/100/1000Mbit/s data transfer rates
 - Support MII/RGMII PHY interface
- **I2C**
 - Up to Five I2C
 - Support standard mode and fast mode(up to 400kbit/s)
- **SDIO**
 - Support SDIO 3.0 protocol
- **SPI**
 - Up to four SPI controllers,
 - Full-duplex synchronous serial interface
- **UART**
 - Support up to 9 UARTs
 - UART2 with 2 wires for debug tools
 - Embedded two 64byte FIFO
 - Support auto flow control mode for UART1-5
- **SATA**
 - Three SATA host controller
 - Support SATA 1.5Gb/s, 3.0Gb/s and SATA 6.0Gb/s
- **ADC**



- Up to Three ADC channels
- 10-bit resolution
- Voltage input range between 0V to 1.8V
- Support up to 1MS/s sampling rate
- **PWM**
 - 14 on-chip PWMs with interrupt-based operation
 - Support 32bit time/counter facility
 - IR option on PWM3/7/11/15
- **Analog Audio**
 - 1.3W@8 ohm Speaker output
 - Headphone stereo output
 - Stereo MIC input
- **Power unit**
 - PMU with audio codec on board
 - 5V and 3.3V input or Single 3.3V input
 - 1.8V max 500mA output
 - Very low RTC consume current, less 5uA at 3V button Cell.

1.3 CM3568 Block Diagram

1.3.1 RK3568 Block Diagram

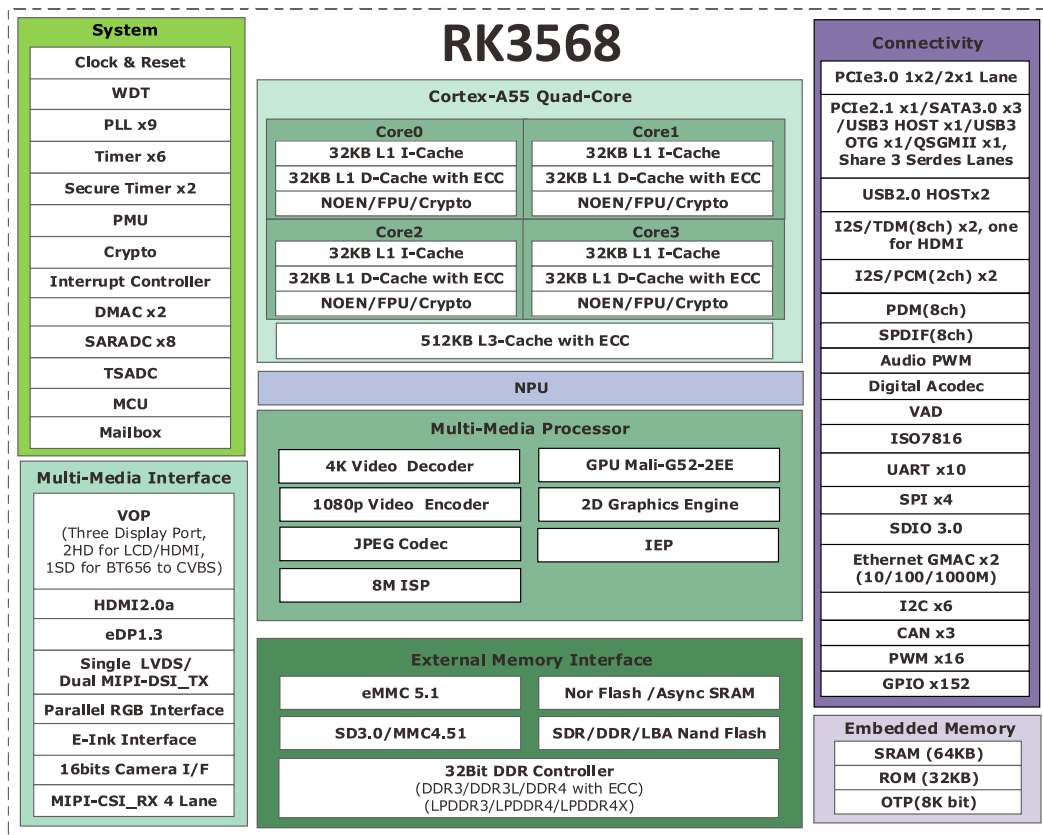

1.3.2 Development board (EM3568) Block Diagram

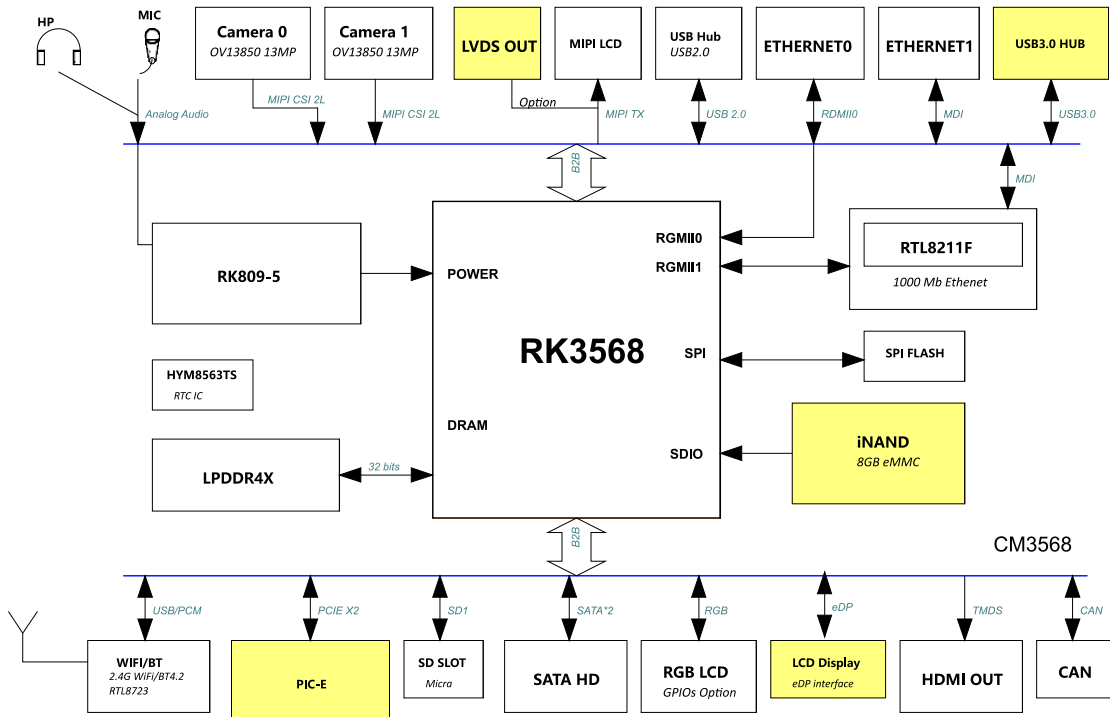

1.4 CM3568 specifications

Feature	Specifications
CPU	Quad-core Cortex-A55
DDR	2GB (up to 8GB)
eMMC FLASH	8GB (up to 128GB)
Power	DC 3.3V or DC 5V&3.3V
LVDS/MIPI DSI	1-CH LVDS or MIPI, 2-CH MIPI DSI
I2S	3-CH
MIPI CSI	1-CH 4-Lane or 2-CH 2-Lane CSI
SATA	3-CH
HDMI out	1-CH
CAN	2-CH
USB	3-CH (USB HOST2.0), 1-CH(OTG 2.0) and 1-CH(USB 3.0)
Ethernet	2-ch GMAC: GMDI, GMII and QSGMII If GMII is not needed, it can be set to SDIO, UART and PCM for WIFI/BT module.
SDMMC	2-CH
SPDIF TX	1-CH
I2C	5-CH
SPI	4-CH



UART	8-CH, 1-CH(DEBUG)
PWM	14-CH
ADC IN	3-CH
Board Dimension	60 x 45mm

1.5 CM3568 PCB Dimension

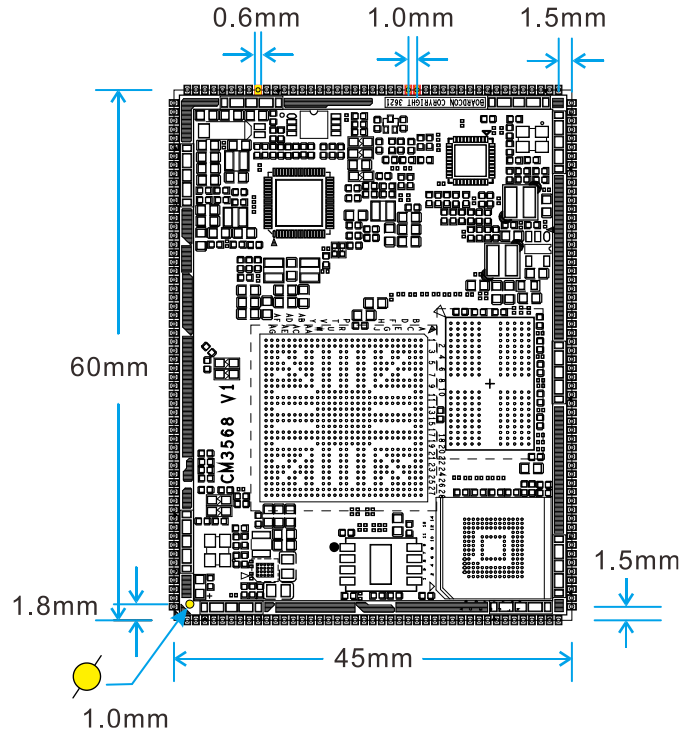

1.6 CM3568 Pin Definition

Pin	Signal	Description or functions	GPIO serial	IO Voltage
1	HDMI_TX0N_PORT			0.5V
2	HDMI_TX0P_PORT			0.5V
3	HDMI_TX1N_PORT			0.5V
4	HDMI_TX1P_PORT			0.5V
5	HDMI_TX2N_PORT			0.5V
6	HDMI_TX2P_PORT			0.5V
7	HDMI_TX_HPDIN	HDMI hot plug detect signal		3.3V
8	PCIE20_REFCLKP	PCIE2 reference clock output		0.5V
9	PCIE20_REFCLKN	PCIE2 reference clock output		0.5V
10	PCIE20_RXP	PCIE2/SATA/QSGMII RX ^P		0.5V
11	PCIE20_RXN	PCIE2/SATA/QSGMII RX ^N		0.5V
12	PCIE20_TXP	PCIE2/SATA/QSGMII TX ^P		0.5V



Pin	Signal	Description or functions	GPIO serial	IO Voltage
13	PCIE20_TXN	PCIE2/SATA/QSGMII TXN		0.5V
14	USB3_HOST1_SSTXN	USB3/SATA/QSGMII TXN		0.5V
15	USB3_HOST1_SSTXP	USB3/SATA/QSGMII TX ^P		0.5V
16	USB3_HOST1_SSRXN	USB3/SATA/QSGMII RXN		0.5V
17	USB3_HOST1_SSRXP	USB3/SATA/QSGMII RX ^P		0.5V
18	USB3_OTG0_SSTXN	USB3 OTG or SATA TXN		0.5V
19	USB3_OTG0_SSTXP	USB3 OTG or SATA TX ^P		0.5V
20	USB3_OTG0_SSRXN	USB3 OTG or SATA RXN		0.5V
21	USB3_OTG0_SSRXP	USB3 OTG or SATA RX ^P		0.5V
22	GND	Ground		0V
23	USB3_HOST1_DM	USB3 Host1 DM		0.5V
24	USB3_HOST1_DP	USB3 Host1 D ^P		0.5V
25	USB3_OTG0_DP	USB3 OTG0 D ^P		0.5V
26	USB3_OTG0_DM	USB3 OTG0 DM		0.5V
27	UART1_RTSn_M0/GMAC0_TXEN	GMAC0_TXEN /UART1_RTSn_M0 or SPI1_CLK_M0	GPIO2_B5_u	1.8V
28	UART1_TX_M0/GMAC0_TXD1	GMAC0_TXD1 or UART1_TXD	GPIO2_B4_u	1.8V
29	UART1_RX_M0/GMAC0_TXD0	GMAC0_TXD0 or UART1_RXD	GPIO2_B3_u	1.8V
30	BT_REG_ON_H_GPIO2_B7/GMAC0_RXD1	GMAC0_RXD1/I2S2_SCK_RX_M0 or SPI1_MOSI_M0	GPIO2_B7_d	1.8V
31	UART1_CTSn_M0/GMAC0_RXD0	GMAC0_RXD0/UART1_CTS or SPI1_MISO_M0	GPIO2_B6_u	1.8V
32	SDMMC1_D1/GMAC0_RXD3	GMAC0_RXD3/SDMMC1_D1 or UART6_TX_M0	GPIO2_A4_u	1.8V
33	SDMMC1_D0/GMAC0_RXD2	GMAC0_RXD2/SDMMC1_D0 or UART6_RX_M0	GPIO2_A3_u	1.8V
34	SDMMC1_CLK/GMAC0_TXCLK	GMAC0_TXCLK/SDMMC1_CLK or UART9_TX_M0	GPIO2_B0_d	1.8V
35	SDMMC1_CMD/GMAC0_TXD3	GMAC0_TXD3/SDMMC1_CMD or UART9_RX_M0	GPIO2_A7_u	1.8V
36	SDMMC1_D3/GMAC0_TXD2	GMAC0_TXD2/SDMMC1_D3 or UART7_TX_M0	GPIO2_A6_u	1.8V
37	SDMMC1_D2/GMAC0_RXCLK	GMAC0_RXCLK/SDMMC1_D2 or UART7_RX_M0	GPIO2_A5_u	1.8V
38	GND	Ground		0V
39	SOC_PCM_CLK/GMAC0_MCLKINOUT	GMAC0_MCLK/I2S2_SCKTx /UART7CTS/SPI2_MISO_M0	GPIO2_C2_d	1.8V
40	SOC_PCM_SYNC/GMAC0_MDC	GMAC0_MDC/I2S2_LRCKTx /UART7RTS/SPI2_MOSI_M0	GPIO2_C3_d	1.8V



Pin	Signal	Description or functions	GPIO serial	IO Voltage
41	SOC_PCM_OUT/GMAC0_MDIO	GMAC0_MDIO/I2S2_SDO /UART9CTS/SPI2_CS0_M0	GPIO2_C4_d	1.8V
42	BT_WAKE_HOST_H/GMAC0_RXDV_CRS	GMAC0_RXDV/I2S2_LRCK Rx/UART6CTS/SPI1CS0_M0	GPIO2_C0_d	1.8V
43	HOST_WAKE_BT_H_GPIO2_C1	I2S2_MCLK/UART7_RTS/SP I2_CLK_M0	GPIO2_C1_d	1.8V
44	EDP_TX_D3N			0.5V
45	EDP_TX_D3P			0.5V
46	EDP_TX_D2N			0.5V
47	EDP_TX_D2P			0.5V
48	EDP_TX_D1N			0.5V
49	EDP_TX_D1P			0.5V
50	EDP_TX_D0N			0.5V
51	EDP_TX_D0P			0.5V
52	EDP_TX_AUXN			0.5V
53	EDP_TX_AUXP			0.5V
54	USB3_OTG0_VBUSDET	USB OTG VBUS detect input		3.3V
55	USB3_OTG0_ID	USB OTG ID input		3.3V
56	SDMMC0_CLK	UART5Tx_M0/CAN0_Rx_M1	GPIO2_A2_d	3.3V
57	SDMMC0_CMD	UART5Rx_M0/CAN0_Tx_M1	GPIO2_A1_u	3.3V
58	SDMMC0_D0	UART6_Tx_M1/PWM8_M1	GPIO1_D5_u	3.3V
59	SDMMC0_D1	UART6_Rx_M1/PWM9_M1	GPIO1_D6_u	3.3V
60	SDMMC0_D2	UART5CTS_M0/JTAG_TCK	GPIO1_D7_u	3.3V
61	SDMMC0_D3	UART5RTS_M0/JTAG_TMS	GPIO2_A0_u	3.3V
62	GND	Ground		0V
63	SARADC_VIN3			1.8V
64	SARADC_VIN2_HP_HOOK			1.8V
65	SARADC_VIN0_KEY/RECOVERY	Program need short to GND when power on.(Pull up 10K)		1.8V
66	GND	Ground		0V
67	GPIO2_C6	UART8_Rx/SPI1_CS1_M0	GPIO2_C6_d	1.8V
68	WIFI_REG_ON_H_GPIO2_B1	UART8_RTS_M0/CAN2_Rx_M1	GPIO2_B1_d	1.8V
69	WIFI_WAKE_HOST_H_GPIO2_B2	UART8_CTS_M0/CAN2_Tx_M1/SD1_DET	GPIO2_B2_u	1.8V
70	SOC_PCM_IN	UART8Tx_M0/I2S2_SDI_M0	GPIO2_C5_d	1.8V
71	UART0_TX/GPIO0_C1	PWM2_M0/MCU_JTAG_TDI	GPIO0_C1_d	3.3V
72	UART0_RX/PWM1_M0		GPIO0_C0_d	3.3V
73	I2C1_SCL/CAN0_TX_M0	PCIE30X1_ButtonRSTn /MCU_JTAG_TDO	GPIO0_B3_u (Pull up 2.2K onboard)	3.3V



Pin	Signal	Description or functions	GPIO serial	IO Voltage
74	I2C1_SDA/CAN0_RX_M0	PCIE20_ButtonRSTn /MCU_JTAG_TCK	GPIO0_B4_u (Pull up 2.2K onboard)	3.3V
75	UART2TX_M0_DEBUG	Debug UART	GPIO0_D1_u	3.3V
76	UART2RX_M0_DEBUG	Debug UART	GPIO0_D0_u	3.3V
77	TP_INT_L_PWM1_M1	SPI0_CLK_M0	GPIO0_B5_u	3.3V
78	LCD0_BL_PWM4	PCIE30X1_PERSTn_M0	GPIO0_C3_d	3.3V
79	PCIE20_CLKREQn_M0 /GPIO0_A5	SDMMC0_PWREN /SATA_MP_SWITCH	GPIO0_A5_d	3.3V
80	PWM3_IR	PCIE30X1_Wake/EDP_HPDP	GPIO0_C2_d	3.3V
81	LCD1_PWREN_H_GPIO0_C5	PCIE30X2_WAKEn_M0 /PWM6 /SPI0_MISO_M0	GPIO0_C5_d	3.3V
82	SDMMC0_DET_L	PCIE30X1_CLKREQn_M0	GPIO0_A4_u	3.3V
83	LCD1_BL_PWM5	UART0_RTS/SPI0_CS1_M0	GPIO0_C4_d	3.3V
84	TP_RST_L_PWM2_M1	SPI0_MOSI_M0	GPIO0_B6_u	3.3V
85	I2C4_SCL_M0	SPI3CLK_M0/I2S2_SDO_M1 (Pull up 2.2K onboard)	GPIO4_B3_d	1.8V
86	I2C4_SDA_M0	SPI3MOSI_M0 /I2S2SDI_M1 (Pull up 2.2K onboard)	GPIO4_B2_d	1.8V
87	I2C2_SCL_M1	CAN2Tx_M0 /I2S1SDO3_M1 (Pull up 2.2K onboard)	GPIO4_B5_d	1.8V
88	I2C2_SDA_M1	CAN2Rx_M0/ISP_Flash_Trig (Pull up 2.2K onboard)	GPIO4_B4_d	1.8V
89	PDM_CLK1_M0_ADC	SPDIF_M0/UART4_Rx_M0	GPIO1_A4_d	3.3V
90	PDM_SDI1_M0_ADC	PCIE20_PERSTn_M2	GPIO1_B2_d	3.3V
91	PDM_SDI2_M0_ADC	PCIE20_WAKEn_M2	GPIO1_B1_d	3.3V
92	PDM_SDI3_M0_ADC	PCIE20_CLKREQn_M2	GPIO1_B0_d	3.3V
93	I2C3_SCL_M0	(Pull up 2.2K onboard)		3.3V
94	I2C3_SDA_M0	(Pull up 2.2K onboard)		3.3V
95	GND	Ground		0V
96	USB2_HOST2_DM			1.8V
97	USB2_HOST2_DP			1.8V
98	USB2_HOST3_DM			1.8V
99	USB2_HOST3_DP			1.8V
100	PHY1_LED2/CFG_LED01	Ethernet Speed LED(PU 4.7K)		3.3V
101	PHY1_LED1/CFG_LED00	Ethernet Link LED(PD 4.7K)		3.3V
102	PHY1_MDIO+			0.5V
103	PHY1_MDIO-			0.5V
104	PHY1_MDII+			0.5V
105	PHY1_MDII-			0.5V



Pin	Signal	Description or functions	GPIO serial	IO Voltage
106	PHY1_MDI2+			0.5V
107	PHY1_MDI2-			0.5V
108	PHY1_MDI3+			0.5V
109	PHY1_MDI3-			0.5V
110	GND	Ground		0V
111	CIF_CLKOUT/PWM11_IR_M1/GPIO4_C0_d		GPIO4_C0_d	1.8V
112	UART7_TX_M1	PDM_CLK1_M2/PWM14_M0	GPIO3_C4_d	3.3V
113	UART7_RX_M1	SPDIFO_M1/PWM15_IR_M0	GPIO3_C5_d	3.3V
114	LCDC_VSYNC/UART5_TX_M1	SPI1_MISO_M1 /VOP_BT1120_D14	GPIO3_C2_d	3.3V
115	LCDC_HSYNC/PCIE20_PERSTn_M1	SPI1_MOSI_M1 /VOP_BT1120_D13	GPIO3_C1_d	3.3V
116	LCDC_DEN/UART5_RX_M1	SPI1_CLK_M1 /VOP_BT1120_D15	GPIO3_C3_d	3.3V
117	RTC32KOUT_WIFI	32.768KHz output(PU 10K)	Open Drain	3.3V
118	SPKP_OUT	1.3W@8Ohm Speaker output		1.8V
119	SPKN_OUT	1.3W@8Ohm Speaker output		1.8V
120	HPL_OUT	Headphone L-CH output		1.8V
121	HPR_OUT	Headphone R-CH output		1.8V
122	MIC1_INN	MIC1 P or MIC_L input		1.8V
123	MIC1_INP	MIC1 N or MIC_R input		1.8V
124	VRTC	RTC button Cell Power input		3.0V
125	LCDC_D23/UART3_RX_M1	PDM_SDI3_M2 /PWM13_M0	GPIO3_C0_d	3.3V
126	LCDC_D22/UART3_TX_M1	PDM_SDI2_M2 /PWM12_M0	GPIO3_C0_d	3.3V
127	LCDC_D21/PWM11_IR_M0	VOP_BT1120_D12	GPIO3_B6_d	3.3V
128	LCDC_D20/GPIO3_B5	VOP_BT1120_D11/PWM10_M0	GPIO3_B5_d	3.3V
129	LCDC_D19/I2C5_SDA_M0	VOP_BT1120_D10/PDM_SDI1_M2	GPIO3_B4_d	3.3V
130	LCDC_D18/I2C5_SCL_M0	VOP_BT1120_D9/PDM_SDI0_M2	GPIO3_B3_d	3.3V
131	LCDC_D17/UART4_TX_M1	VOP_BT1120_D8/PWM9_M0	GPIO3_B2_d	3.3V
132	LCDC_D16/UART4_RX_M1	VOP_BT1120_D7/PWM8_M0	GPIO3_B1_d	3.3V
133	LCDC_D15/GPIO3_B0	VOP_BT1120_D6	GPIO3_B0_d	3.3V
134	LCDC_D14/GPIO3_A7	VOP_BT1120_D5/SD2_DET	GPIO3_A7_d	3.3V
135	LCDC_D13/I2S3_SDI_	VOP_BT1120_CLK	GPIO3_A6_d	3.3V



Pin	Signal	Description or functions	GPIO serial	IO Voltage
	M0	/SDMMC2_CLK_M1		
136	LCDC_D12/I2S3_SDO_M0	VOP_BT1120_D4 /SDMMC2_CMD_M1	GPIO3_A5_d	3.3V
137	LCDC_D11/I2S3_LRCK_M0	VOP_BT1120_D3 /SDMMC2_D3_M1	GPIO3_A4_d	3.3V
138	LCDC_D10/I2S3_SCLK_M0	VOP_BT1120_D2 /SDMMC2_D2_M1	GPIO3_A3_d	3.3V
139	LCDC_D9/I2S3_MCLK_M0	VOP_BT1120_D1 /SDMMC2_D1_M1	GPIO3_A2_d	3.3V
140	GND	Ground		0V
141	RK809_PWRON	Connect to Power Button		3.3V
142	VCC_3V3	3.3V System Power input		3.3V
143	VCC_SYS	3.3-5V Main Power input		3.3-5V
144	VCC_SYS	3.3-5V Main Power input		3.3-5V
145	RESETn	Connect to Reset Button		3.3V
146	VCC_1V8	1.8V IO Power output	(Max out: 500mA)	1.8V
147	LCDC_D8/GPIO3_A1	VOP_BT1120_D0 /SPI1_CS0	GPIO3_A1_d	3.3V
148	LCDC_D7/SPI2_MISO_M1/I2S1_SDO0_M2/UART8_TX_M1	VOP_BT656_D7_M0	GPIO2_D7_d	3.3V
149	LCDC_D6/SPI2_MOSI_M1/I2S1_SDI3_M2	VOP_BT656_D6_M0 /PCIE30X2_PERSTn_M1	GPIO2_D6_d	3.3V
150	LCDC_D5/SPI2_CS0_M1/I2S1_SDI2_M2	VOP_BT656_D5_M0 /PCIE30X2_WAKEn_M1	GPIO2_D5_d	3.3V
151	LCDC_D4/SPI0_CS1_M1/I2S1_SDI1_M2	VOP_BT656_D4_M0 /PCIE30X2_CLKREQn_M1	GPIO2_D4_d	3.3V
152	LCDC_D3/SPI0_CLK_M1/I2S1_SDI0_M2	VOP_BT656_D3_M0 /PCIE30X1_WAKEn_M1	GPIO2_D3_d	3.3V
153	LCDC_D2/SPI0_CS0_M1/I2S1_LRCKTx_M2	VOP_BT656_D2_M0 /PCIE30X1_CLKREQn_M1	GPIO2_D2_d	3.3V
154	LCDC_D1/SPI0_MOSI_M1/I2S1_SCLKTx_M2	VOP_BT656_D1_M0 /PCIE20_WAKEn_M1	GPIO2_D1_d	3.3V
155	LCDC_D0/SPI0_MISO_M1/I2S1_MCLK_M2	VOP_BT656_D0_M0 /PCIE20_CLKREQn_M1	GPIO2_D0_d	3.3V
156	SATA1_ACT_LED/UART9_TX_M1	SPI3_MISO_M1/I2S3_SDO_M1 /PWM12_M1	GPIO4_C5_d	3.3V
157	SATA0_ACT_LED/UART9_RX_M1	SPI3_CS0_M1/I2S3_SDI_M1 /PWM13_M1	GPIO4_C6_d	3.3V
158	CAN1_RX_M1	SPI3_CLK_M1/I2S3_MCLK_M1/PCIE3X2_CLKREQn_M2	GPIO4_C2_d	3.3V
159	CAN1_TX_M1/PWM15	SPI3_MOSI_M1/I2S3_SCLK	GPIO4_C3_d	3.3V



Pin	Signal	Description or functions	GPIO serial	IO Voltage
	_IR_M1	_M1/PCIE3X2_WAKEn_M2		
160	LCDC_CLK/SPI2_CLK _M1/I2S1_SDO1_M2/U ART8_RX_M1	VOP_BT656_CLK_M0	GPIO3_A0_d	3.3V
161	GND	Ground		0V
162	HDMITX_CEC_M0	SPI3_CS1_M1	GPIO4_D1_u	3.3V
163	HDMITX_SDA	I2C5_SDA_M1	GPIO4_D0_u	3.3V
164	HDMITX_SCL	I2C5_SCL_M1	GPIO4_C7_u	3.3V
165	SPDIF_TX_M2/SATA2_ ACT_LED	I2S3_LRCK_M1/PCIE30X2_ PERSTn_M2/EDP_HPD_M0	GPIO4_C4_d	3.3V
166	MIPI_CSI_RX_D3N	MIPI_CSI_RX1_D1N		0.5V
167	MIPI_CSI_RX_D3P	MIPI_CSI_RX1_D1P		0.5V
168	MIPI_CSI_RX_D2P	MIPI_CSI_RX1_D0P		0.5V
169	MIPI_CSI_RX_D2N	MIPI_CSI_RX1_D0N		0.5V
170	MIPI_CSI_RX_CLK1N	MIPI_CSI_RX1_CLKN		0.5V
171	MIPI_CSI_RX_CLK1P	MIPI_CSI_RX1_CLKP		0.5V
172	MIPI_CSI_RX_CLK0N			0.5V
173	MIPI_CSI_RX_CLK0P			0.5V
174	MIPI_CSI_RX_D1N			0.5V
175	MIPI_CSI_RX_D1P			0.5V
176	MIPI_CSI_RX_D0N			0.5V
177	MIPI_CSI_RX_D0P			0.5V
178	MIPI_DSI_TX0_D3P/LV DS_TX0_D3P			0.5V
179	MIPI_DSI_TX0_D3N/L VDS_TX0_D3N			0.5V
180	MIPI_DSI_TX0_D2P/LV DS_TX0_D2P			0.5V
181	MIPI_DSI_TX0_D2N/L VDS_TX0_D2N			0.5V
182	MIPI_DSI_TX0_CLKP/ LVDS_TX0_CLKP			0.5V
183	MIPI_DSI_TX0_CLKN/ LVDS_TX0_CLKN			0.5V
184	MIPI_DSI_TX0_D1P/LV DS_TX0_D1P			0.5V
185	MIPI_DSI_TX0_D1N/L VDS_TX0_D1N			0.5V
186	MIPI_DSI_TX0_D0P/LV DS_TX0_D0P			0.5V
187	MIPI_DSI_TX0_D0N/L VDS_TX0_D0N			0.5V



Pin	Signal	Description or functions	GPIO serial	IO Voltage
188	LCD0_PWREN_H_GPI O0_C7	UART0_CTSn /PWM0_M1	GPIO0_C7_d	3.3V
189	REFCLK_OUT		GPIO0_A0_d	3.3V
190	GND	Ground		0V
191	MIPI_DSI_TX1_D3P			0.5V
192	MIPI_DSI_TX1_D3N			0.5V
193	MIPI_DSI_TX1_D2P			0.5V
194	MIPI_DSI_TX1_D2N			0.5V
195	MIPI_DSI_TX1_CLKP			0.5V
196	MIPI_DSI_TX1_CLKN			0.5V
197	MIPI_DSI_TX1_D1P			0.5V
198	MIPI_DSI_TX1_D1N			0.5V
199	MIPI_DSI_TX1_D0P			0.5V
200	MIPI_DSI_TX1_D0N			0.5V
201	HDMI_TXCLKN_PORT			0.5V
202	HDMI_TXCLKP_PORT			0.5V

Note:

I2C3 can't be used for exclusive bus, Such as CTP.

RGMIIO(Pin27-43,Pin67-70) default is 1.8V IO, but can change to 3.3V.

1.7 Development Kit (EM3568)

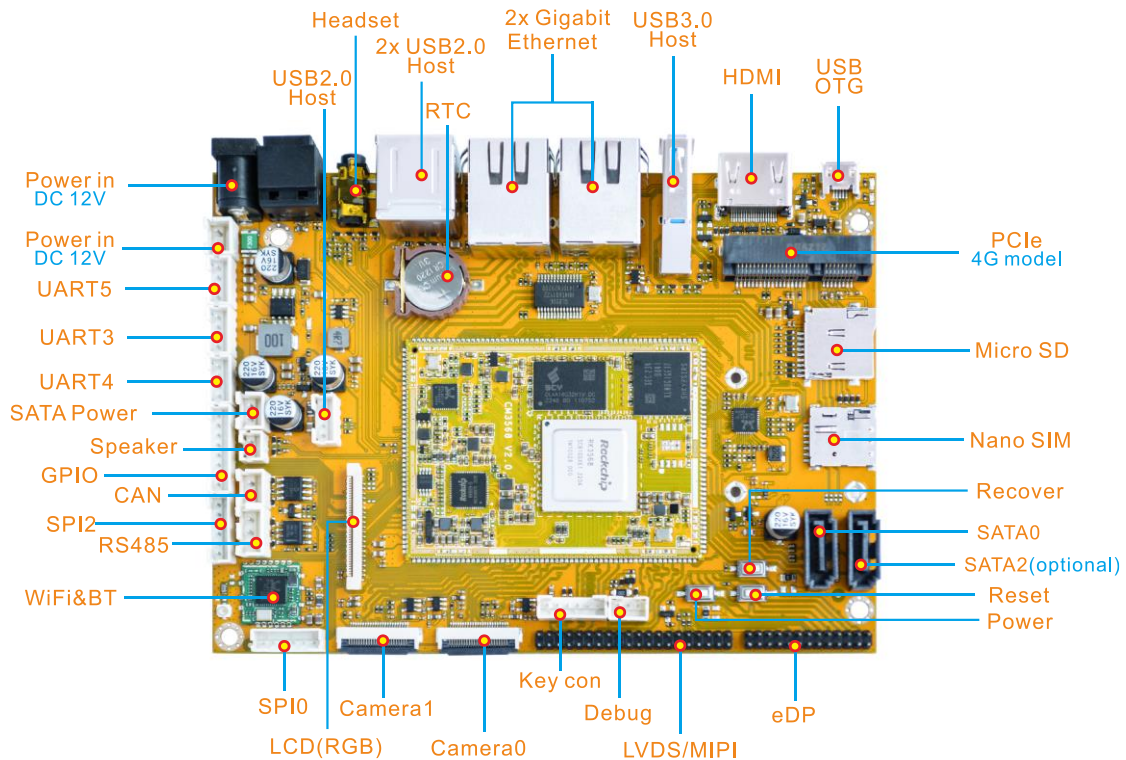



2 Hardware Design Guide

2.1 Peripheral Circuit Reference

2.1.1 External Power

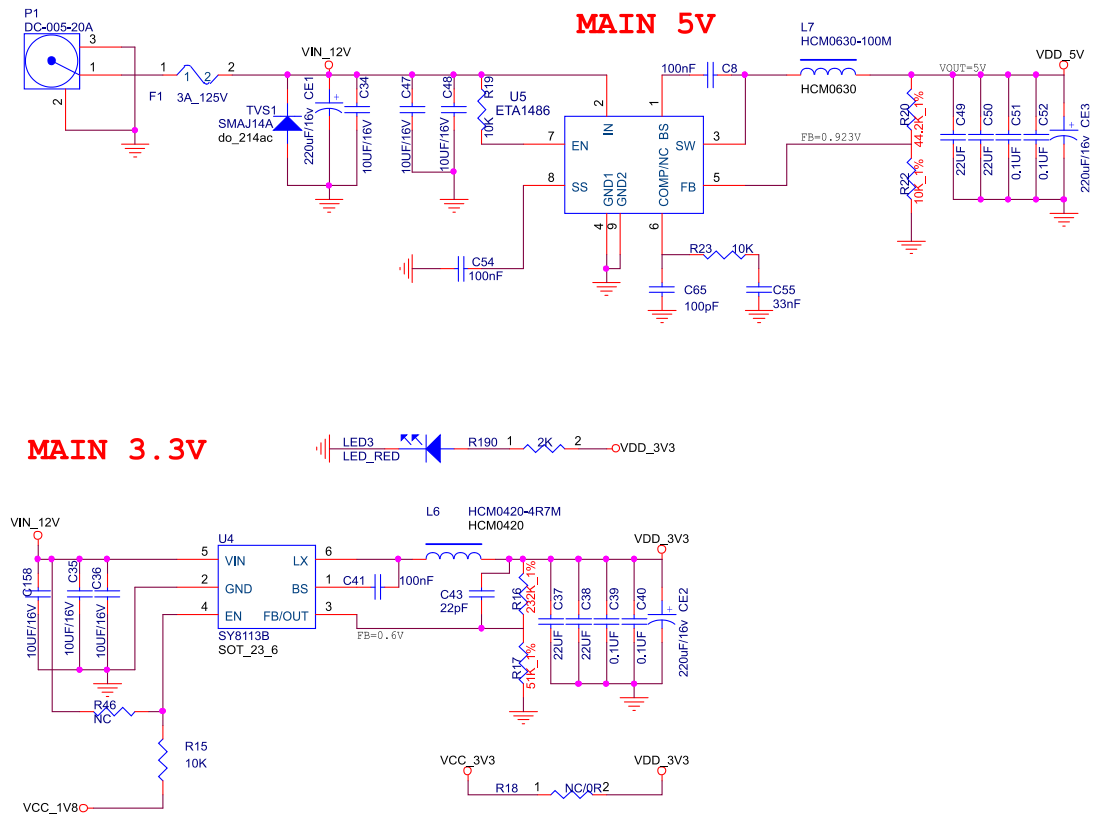

2.1.2 Debug Circuit

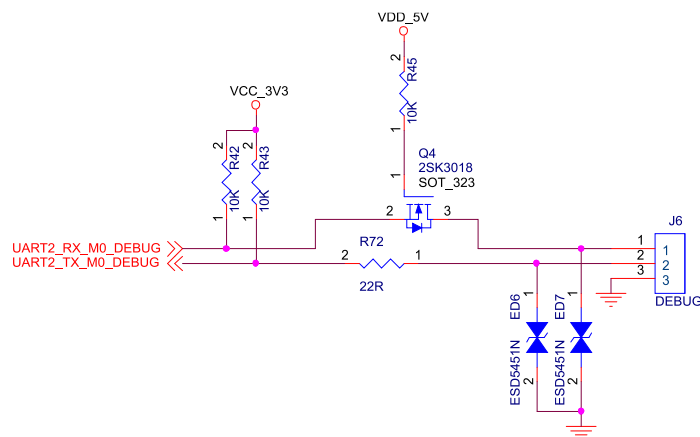



3 Product Electrical Characteristics

3.1 Dissipation and Temperature

Symbol	Parameter	Min	Typ	Max	Unit
VCC_SYS	System IO Voltage	3.3V	5	5.5	V
I _{sys_in}	VCC_SYS input Current		750		mA
VCC3V3_SYS	System IO Voltage	3.3-5%	3.3	3.3+5%	V
I _{sys3v3_in}	VCC_SYS input Current		500		mA
VCC_RTC	RTC Voltage	1.8	3	3.4	V
I _{rtc}	RTC input Current		5	8	uA
T _a	Operating Temperature	-20		70	°C
T _{stg}	Storage Temperature	-40		85	°C

3.2 Reliability of Test

High Temperature Operating Test		
Contents	Operating 8h in high temperature	55°C ± 2°C
Result		

Operating Life Test		
Contents	Operating in room	120h
Result		