

CM3588S Reference User Manual

V1. 20230228

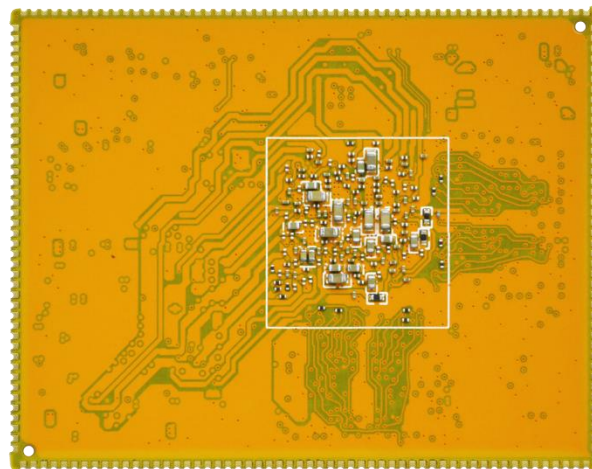
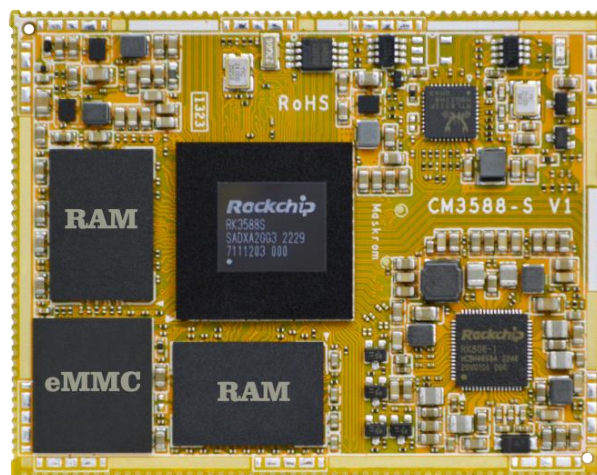

Boardcon Embedded Design

www.boardcon.com

1. Introduction

1.1. About this Manual

This manual is intended to provide the user with an overview of the board and benefits, complete features specifications, and set up procedures. It contains important safety information as well.

1.2. Feedback and Update to this Manual

To help our customers make the most of our products, we are continually making additional and updated resources available on the Boardcon website (www.boardcon.com, www.armdesigner.com).

These include manuals, application notes, programming examples, and updated software and hardware. Check in periodically to see what's new!

When we are prioritizing work on these updated resources, feedback from customers is the number one influence. If you have questions, comments, or concerns about your product or project, please do not hesitate to contact us at support@armdesigner.com.

1.3. Limited Warranty

Boardcon warrants this product to be free of defects in material and workmanship for a period of one year from date of buy. During this warranty period Boardcon will repair or replace the defective unit in accordance with the following process:

A copy of the original invoice must be included when returning the defective unit to Boardcon. This limited warranty does not cover damages resulting from lightning or other power surges, misuse, abuse, abnormal conditions of operation, or attempts to alter or modify the function of the product.

This warranty is limited to the repair or replacement of the defective unit. In no event shall Boardcon be liable or responsible for any loss or damages, including but not limited to any lost profits, incidental or consequential damages, loss of business, or anticipatory profits arising from the use or inability to use this product.

Repairs made after the expiration of the warranty period are subject to a repair charge and the cost of return shipping. Please contact Boardcon to arrange for any repair service and to obtain repair charge information.



Content

1 CM3588S Introduction	3
1.1 Summary	3
1.2 Features.....	3
1.3 CM3588S Block Diagram.....	5
1.4 CM3588S specifications	6
1.5 CM3588S PCB Dimension.....	7
1.6 CM3588S Pin Definition	7
1.7 Development Kit (Idea3588S)	15
2 Hardware Design Guide.....	16
2.1 Peripheral Circuit Reference	16
2.2 Mother Board length offset.....	17
2.3 PCB Footprint	18
3 Product Electrical Characteristics	18
3.1 Dissipation and Temperature	18
3.2 Reliability of Test.....	19

1 CM3588S Introduction

1.1 Summary

The CM3588S system-on-module is equipped with Rockchip's RK3588S it has a quad-core Cortex-A76 and a quad-core Cortex-A55 processor, Embedded Mali-G610 MP4 GPU and 6.0 TOPs NPU.

It is designed specifically for the high-performance devices such as 8K TV box or recorder, VI devices, intelligent interactive devices, personal computers and robots. The high-performance multimedia processing and acceleration engine solution can help customers to introduce new technologies more quickly and enhance the overall solution efficiency.

1.2 Features

- **Microprocessor**
 - Quad-core Cortex-A76 up to 2.4GHz
 - Quad-core Cortex-A55 up to 1.8GHz
 - 64KB I-cache 64KB D-cache and 512KB L2 for A76 each core, 32KB I-cache 32KB D-cache and 512KB L2 for A55 each core, 3MB L3 cache
 - 6.0 TOPs Neural Process Unit, Embedded 384KB*3 internal buffer
 - Mali-G610 MP4 up to 0.8GHz
- **Memory Organization**
 - LPDDR4 or LPDDR4X RAM up to 16GB
 - EMMC up to 128GB
- **Boot ROM**
 - Supports system code download through USB OTG
- **Secure system**
 - Embedded two cipher engine
 - Support key ladder to guarantee key secure
 - Support secure OS and data scrambling
 - Support OTP
- **Video Decoder/Encoder**
 - Supports video decoding up to 8K@60fps
 - Supports H.264/265 encode up to 8K@30fps
 - H.264 HP encoding up to 1080p@100fps
 - Picture size up to 8192x8192
- **NPU**
 - Include Triple NPU core
 - Support deep learning frameworks
- **Display Subsystem**
 - **Video Output**
 - Supports HDMI 2.1 TX with ARC, up to 8K@60fps
 - Or EDP TX interface up to 4K@60Hz



HDMI 2.1 support FRL mode
Supports 4 lanes MIPI DSI up to 4K@60Hz
Supports PD1.4a interface up to 8K@30Hz
Supports BT-1120 16bit output

- **Video/Image Input**

Supports 2-CH MIPI 4lanes CSI interfaces
Or 2-CH MIPI 2lanes + 1-CH 4lanes CSI interfaces
Supports DVP 8/16-bit input

• **Audio**

- Three I2S/PCM interfaces
- Support 8-ch TX/RX on I2S0/1
- Support Mic array Up to 8ch PDM/TDM interface
- Support 2-ch SPDIF output
- Support voice activity detection

• **USB / PCIE/SATA3**

- One USB2.0 OTG and two USB2.0 Host interfaces
- One Type-C or DP interfaces
- One USB3.0 Host or SATA3 interface.
- One PCIE2.1x1 or SATA3 interface.
- One SATA3 interface.
- One PCIE3.0x2 interface
- SATA3 support five device each port via PM switch

• **Ethernet**

- On board RTL8211F

• **I2C**

- Up to 7-CH I2C
- Support standard mode and fast mode(up to 400kbit/s)

• **SDIO / SDMMC**

- Support SDIO 3.0 protocol
- Support SD3.0 card

• **SPI**

- Up to four SPI controllers,
- Full-duplex synchronous serial interface

• **UART**

- Support up to 10 UARTs
- UART2 with 2 wires for debug
- Embedded two 64byte FIFO

• **CAN**

- Support up to three CAN controller
- Support CAN 2.0B protocol

• **ADC**

- Up to Three ADC channels
- 12-bit resolution up to 1MS/s sampling rate
- Voltage input range between 0V to 1.8V

- **PWM**
 - Up to 15 PWMs with interrupt-based operation
 - Support 32bit time/counter facility
 - IR option on PWM3/7/11/15
- **Power unit**
 - PMU RK806 on board
 - 3.4 ~ 4.5V main power input
 - 1.8V and 3.3V max 500mA output
 - Very low RTC consume current, less 5uA at 3V button Cell.

1.3 CM3588S Block Diagram

1.3.1 RK3588S Block Diagram

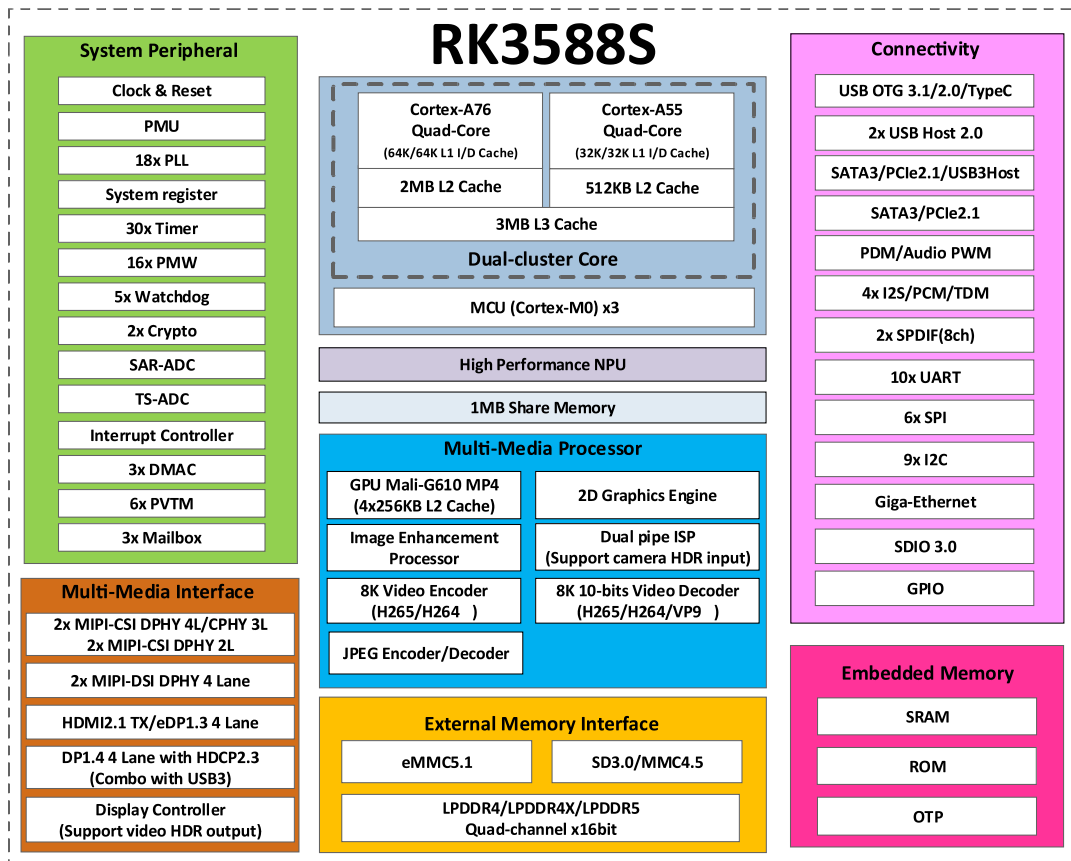

1.3.2 Development board (Idea3588S) Block Diagram

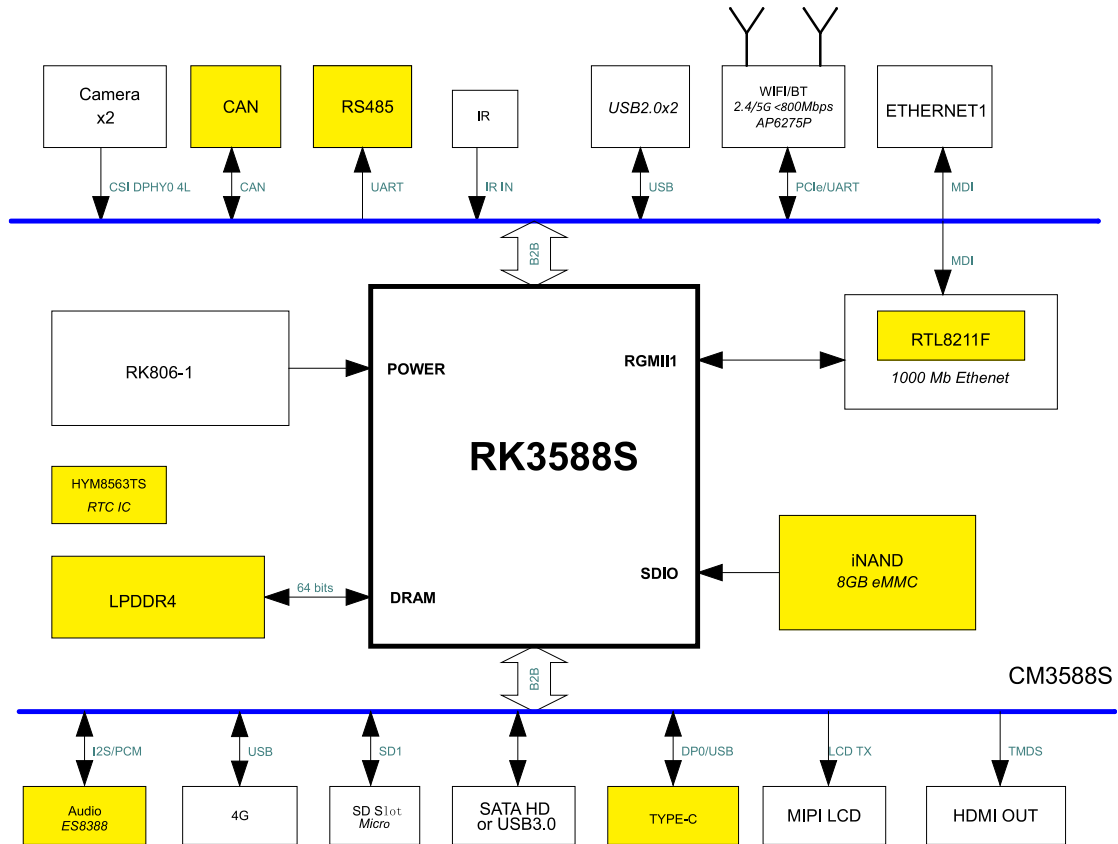

1.4 CM3588S specifications

Feature	Specifications
CPU	Quad-core Cortex-A72 and quad-core Cortex-A55
DDR	4GB LPDDR4 (up to 16GB)
eMMC FLASH	8GB (up to 128GB)
Power	DC 3.4 ~ 4.5V
EDP/MIPI DSI	1-CH EDP, 1-CH MIPI DSI
I2S	3-CH
MIPI CSI	2-CH 4-Lane or 2-CH 2-Lane + 1-CH 4-Lan CSI (up to 3 CSI Cameras)
SATA	2-CH
HDMI out	1-CH (EDP option)
DP out	1-CH
CAN	3-CH
USB	1-CH USB Host2.0 + 1-CH Type C and 1-CH USB Host3.0
Ethernet	1-ch 1 GB PHY
SDMMC	2-CH



Feature	Specifications
SPDIF TX	2-CH
I2C	7-CH
SPI	4-CH
CAN	3-CH
UART	9-CH, 1-CH(DEBUG)
PWM	15-CH
ADC IN	3-CH
Board Dimension	57.5 x 45mm

1.5 CM3588S PCB Dimension

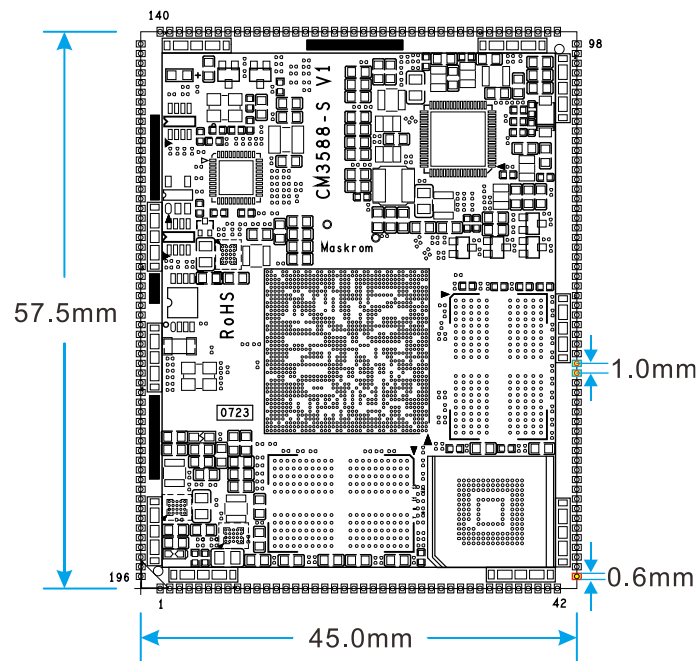

1.6 CM3588S Pin Definition

Pin	Signal	Description or functions	GPIO serial	IO Voltage
1	VCC_SYS	System Power Input		3.4V-4.5V
2	VCC_SYS	System Power Input		3.4V-4.5V
3	VCC_SYS	System Power Input		3.4V-4.5V
4	GND	Ground		0V
5	PWM7_IR_M0_1V8	I2C6_SCL_M0/PDM0_SDI1_M1	GPIO0_D0_d	1.8V
6	BT_REG_ON_H_1V8	I2C1_SCL_M2/PDM0_SDI2_M1/CAN2_RX_M1/PWM3_IR	GPIO0_D4_u/SATA_CPDET/HDMI_SDA	1.8V



Pin	Signal	Description or functions	GPIO serial	IO Voltage
7	BT_WAKE_HOST_H_1V8	I2C4_SCL_M2/UART0_TX_M0 /PWM4_M0	GPIO0_C5_u	1.8V
8	HOST_WAKE_BT_H_1V8	UART0_RTSn_M0 /PWM5_M1/SATA_CP_POD	GPIO0_C6_u	1.8V
9	WIFI_WAKE_HOST_H_1V8	REFCLK_OUT	GPIO0_A0_d	1.8V
10	WIFI_REG_ON_H_1V8	I2C6_SDA_M0/PDM0_SDI0_M1/PWM6_M0	GPIO0_C7_d	1.8V
11	GND	Ground		0V
12	PDM0_CLK0_1V8	I2C4_SDA_M4/PDM0_CLK0_M0/PWM15_IR_M2	GPIO1_C6_d	1.8V
13	PDM0_CLK1_1V8	I2C2_SDA_M3/PDM0_CLK1_M0/PWM11_IR_M2/SPI4_CS1_M0	GPIO1_C4_d	1.8V
14	PDM0_SDI0_1V8	PDM0_SDI0_M0/SPI1_CS1_M2	GPIO1_D5_d	1.8V
15	GND	Ground		0V
16	UART6_TX_M1_1V8	PCIE20x1_1_WAKE_M2/I2C2_SCL_M4/SPI4_MOSI_M2	GPIO1_A1_d	1.8V
17	UART6_RX_M1_1V8	PCIE20x1_1_CLKREQ_M2/I2C2_SDA_M4/SPI4_MISO_M2/DP0_HPDIN_M2	GPIO1_A0_d	1.8V
18	UART6_RTSn_M1_1V8	I2C4_SDA_M3/PWM0_M2/SPI4_CLK_M2/VOP_POST_EMPTY	GPIO1_A2_d	1.8V
19	UART6_CTSn_M1_1V8	I2C4_SCL_M3/PWM1_M2/SPI4_CS0_M2	GPIO1_A3_d	1.8V
20	GPIO1_A7_u_1V8	PCIE20x1_1_PERSTN_M2/PDM1_SDI0_M1/PWM3_M3	GPIO1_A7_u	1.8V
21	GPIO1_B0_u_1V8	PDM1_SDI1_M1	GPIO1_B0_u	1.8V
22	GPIO1_A4_d_1V8		GPIO1_A4_d	1.8V
23	GPIO1_A5_d_1V8	HDMI_TX0_HPD_M0	GPIO1_A5_d	1.8V
24	GPIO1_A6_d_1V8		GPIO1_A6_d	1.8V
25	GND	Ground		0V
26	MIPI_CAM4_CLK_M0_1V8	UART1_CTS_M1/I2C8_SDA_M2/PWM15_IR_M3	GPIO1_D7_u	1.8V
27	GND	Ground		0V
28	SPI0_CS1_M2_1V8	UART7_TX_M2	GPIO1_B5_u	1.8V
29	SPI0_CS0_M2_1V8	UART7_RX_M2/PDM1_CLK0_M1	GPIO1_B4_u	1.8V
30	SPI0_MISO_M2_1V8	PDM1_SDI2_M1	GPIO1_B1_d	1.8V



Pin	Signal	Description or functions	GPIO serial	IO Voltage
31	SPI0_MOSI_M2_1V8	UART4_RX_M2/ PDM1_ SDI3_M1	GPIO1_B2_d	1.8V
32	SPI0_CLK_M2_1V8	UART4_TX_M2/ PDM1_CLK1_M1//SATA0_A CT_LED_M1	GPIO1_B3_d	0V
33	GND	Ground		0V
34	MIPI_CAM3_CLK_M0_1V8	UART1_RTS_M1/I2C8_SCL_M2/PWM14_M2	GPIO1_D6_u	1.8V
35	GND	Ground		0V
36	GPIO3_B7_d	I2C3_SCL_M1 /SPI1_MOSI_M1	GPIO2_B7_d	3.3V
37	UART7_TX_M1	I2C3_SDA_M1 /SPI1_MISO_M1	GPIO3_C0_d	3.3V
38	UART7_RX_M1	SPI1_CLK_M1	GPIO3_C1_d	3.3V
39	CAN2_TX_M0	UART5_RX_M1/SPI3_CS1_M3/CIF_D9/FSPI_CS1N_M2	GPIO3_C5_u	3.3V
40	CAN2_RX_M0	UART5_TX_M1/SPI3_CS0_M3/CIF_D8/FSPI_CS0N_M2	GPIO3_C4_u	3.3V
41	PWM11_IR_M3	UART9_TX_M2/SPI0_CS1_M3/MCU_JTAG_TMS_M1	GPIO3_D5_d	3.3V
42	PWM13_M1	I2C5_SCL_M1/SPI3_MOSI_M1/BT1120_D12/SATA0_AC T_LED_M0	GPIO4_B6_d	3.3V
43	GPIO3_C6_u	SPI3_MISO_M3/CIF_D10	GPIO3_C6_u	3.3V
44	UART9_TX_M1	DP0_HPDIN_M0/I2S1_SDO3_M0/SPDIF0_TX_M1/CIF_CLKOUT/BT1120_D10	GPIO4_B4_u /PWM11_IR_M1	3.3V
45	UART9_RX_M1	SPI3_MISO_M1/PWM12_M1 /BT1120_D11	GPIO4_B5_d	3.3V
46	UART8_TX_M0	SPI2_CS1_M1/I2C6_SDA_M3/I2S1_SDI3_M0/BT1120_C LKOUT/CIF_CLKIN	GPIO4_B0_d	3.3V
47	UART8_RX_M0	SPI0_CS1_M1/I2C6_SCL_M3/I2S1_SDO0_M0/SPDIF1_T X_M1/CAM0_CLK_M0	GPIO4_B1_u	3.3V
48	UART8_CTSN_M0	I2C7_SDA_M3/I2S1_SDO2_M0/CAN1_TX_M1/CIF_VSY NC/BT1120_D9/PWM15_IR_M1	GPIO4_B3_u	3.3V
49	UART8_RTSN_M0	SPI0_CS0_M1/I2C7_SCL_M3/I2S1_SDO1_M0/CAN1_RX_M1/CIF_HREF/BT1120_D8/ PWM14_M1	GPIO4_B2_u	3.3V



Pin	Signal	Description or functions	GPIO serial	IO Voltage
50	UART3_TX_M2	SPI2_MOSI_M1/I2C3_SDA_M2/I2S1_SDI0_M0/CIF_D5/BT1120_D5	GPIO4_A5_d	3.3V
51	UART3_RX_M2	SPI2_CLK_M1/I2C5_SCL_M2/I2S1_SDI1_M0/CIF_D6/BT1120_D6	GPIO4_A6_d	3.3V
52	GPIO4_A7_d	SPI2_CS0_M1/I2C5_SDA_M2/I2S1_SDI2_M0/CIF_D7/BT1120_D7	GPIO4_A7_d	3.3V
53	PCIE20x1_1_PERSTn_M1	SPI0_CLK_M1/I2S1_LRCK_M0/CIF_D2/BT1120_D2	GPIO4_A2_d	3.3V
54	PCIE20x1_1_CLKREQn_M1	SPI0_MISO_M1/I2S1_MCLK_M0/UART9_RTSn_M1/CIF_D0/BT1120_D0	GPIO4_A0_d	3.3V
55	PCIE20x1_1_WAKEn_M1	SPI0_MOSI_M1/I2S1_SCLK_M0/UART9_CTSn_M1/CIF_D1/BT1120_D1	GPIO4_A1_d	3.3V
56	UART0_TX_M2	CIF_D3/BT1120_D3	GPIO4_A3_d	3.3V
57	UART0_RX_M2	SPI2_MISO_M1/I2C3_SCL_M2/ CIF_D4/BT1120_D4	GPIO4_A4_d	3.3V
58	GND	Ground		0V
59	TYPEC0_OTG_ID_1V8	USB20 OTG ID input		1.8V
60	TYPEC0_OTG_VBUSDET	USB OTG VBUS detect input		3.3V
61	GND	Ground		0V
62	USB20_HOST0_DM			1.8V
63	USB20_HOST0_DP			1.8V
64	USB20_HOST1_DM			1.8V
65	USB20_HOST1_DP			1.8V
66	TYPEC0_OTG_DM			1.8V
67	TYPEC0_OTG_DP			1.8V
68	GND	Ground		0V
69	SDMMC0_CLK	CAN0_RX_M1/UART5_TX_M0/PDM1_CLK0_M0	GPIO4_D5_d	3.3V
70	SDMMC0_CMD	CAN0_TX_M1/UART5_RX_M0/PDM1_CLK1_M0	GPIO4_D4_u/PWM7_IR_M1	3.3V
71	SDMMC0_D3	UART5_RTS_M0/PDM1_SDI0_M0/I2C8_SDA_M0	GPIO4_D3_u/PWM10_M1	3.3V
72	SDMMC0_D2	UART5_CTS_M0/PDM1_SDI1_M0/I2C8_SCL_M0	GPIO4_D2_u	3.3V
73	SDMMC0_D1	UART2_RX_M1/PDM1_SDI2_M0/I2C3_SDA_M4	GPIO4_D1_u/PWM9_M1	3.3V



Pin	Signal	Description or functions	GPIO serial	IO Voltage
74	SDMMC0_D0	UART2_TX_M1/PDM1_SDI3_M0/I2C3_SCL_M4	GPIO4_D0_u /PWM8_M1	3.3V
75	GND	Ground		0V
76	HDMI0_TX_SBDN/eDP0_TX_AUXN	HDMI0_TX_eARC- /eDP0_TX_AUXN	(Default HDMI)	0.5V
77	HDMI0_TX_SBDP/eDP0_TX_AUXP	HDMI0_TX_eARC+ /eDP0_TX_AUXP	(Default HDMI)	0.5V
78	HDMI0_TX3N	HDMI0TX_CLKN/eDP0TX3N	(Default HDMI)	0.5V
79	HDMI0_TX3P	HDMI0TX_CLKP/eDP0TX3P	(Default HDMI)	0.5V
80	HDMI0_TX0N	HDMI0_TX /eDP0_TX0N	(Default HDMI)	0.5V
81	HDMI0_TX0P	HDMI0_TX /eDP0_TX0P	(Default HDMI)	0.5V
82	HDMI0_TX1N	HDMI0_TX /eDP0_TX1N	(Default HDMI)	0.5V
83	HDMI0_TX1P	HDMI0_TX /eDP0_TX1P	(Default HDMI)	0.5V
84	HDMI0_TX2N	HDMI0_TX /eDP0_TX2N	(Default HDMI)	0.5V
85	HDMI0_TX2P	HDMI0_TX /eDP0_TX2P	(Default HDMI)	0.5V
86	GND	Ground		0V
87	HDMI_TX0_SCL_M0	SPI3_CLK_M1/I2C5_SDA_M1/BT1120_D13	GPIO4_B7_u	3.3V
88	HDMI_TX0_SDA_M0	SPI3_CS0_M1/I2C8_SCL_M3/BT1120_D14	GPIO4_C0_u	3.3V
89	HDMI_TX0_CEC_M0	SPI3_CS1_M1/I2C8SDA_M3 /SPDIF1TX_M2/BT1120_D15	GPIO4_C1_d	3.3V
90	HDMI_TX0_HPD_M1	SPI0_CS0_M3/UART9_RX_M2/MCU_JTAG_TCK_M1	GPIO3_D4_d	3.3V
91	PCIE20x1_2_CLKREQn_M0	SPI3_MOSI_M3/I2C5_SCL_M0/HDMI_TX0_SCL_M2/CIF_D11	GPIO3_C7_u	3.3V
92	PCIE20x1_2_PERSTn_M0	SPI0_MISO_M3/UART4_TX_M1/PWM9_M2/CIF_D13	GPIO3_D1_d	3.3V
93	PCIE20x1_2_WAKEn_M0	SPI3_CLK_M3/UART4_RX_M1/I2C5_SDA_M0/HDMI_TX0_SDA_M2/CIF_D12	GPIO3_D0_u /PWM8_M2	3.3V
94	UART2_RX_M0	I2C1_SDA_M0/JATG_TMS_M2/PCIE20X1_1_WAKE_M0	GPIO0_B6_d (Debug UART) (PU10K)	3.3V
95	UART2_TX_M0	I2C1_SCL_M0/JATG_TCK_M2/PCIE20X1_CLKREQ_M0	GPIO0_B5_d (Debug UART) (PU10K)	3.3V
96	I2C7_SDA_M2	SPI0_CLK_M3/UART9_CTS_N_M2/PWM10_M2/CIF_D15	GPIO3_D3_d (PU2.2K)	3.3V
97	I2C7_SCL_M2	SPI0_MOSI_M3/UART9_RT SN_M2 /CIF_D14	GPIO3_D2_d (PU2.2K)	3.3V
98	GND	Ground		0V
99	SDMMC_DET_1V8	SD Card DET(Need pull up)	GPIO0_A4_u	1.8V



Pin	Signal	Description or functions	GPIO serial	IO Voltage
100	PWRON_L	Power Key input	(PU)	3.4~4.5V
101	RESET_L	System Reset (to RST_KEY)	(PU10K)	1.8V
102	VCC_1V8	1.8V IO power output (PMU_Buck10)	(Max:500mA)	1.8V
103	GND	Ground		0V
104	TYPEC0_SBU1/DP_A UXN	TYPEC0_SBU2/DP0_AUXN	(Default TYPE-C)	0.5V
105	TYPEC0_SBU1/DP_A UXP	TYPEC0_SBU1/DP0_AUXP	(Default TYPE-C)	0.5V
106	TYPEC0_SSRX1N	TYPEC0_RX1N/DP0_TX0N	(Default TYPE-C)	0.5V
107	TYPEC0_SSRX1P	TYPEC0_RX1P/DP0_TX0P	(Default TYPE-C)	0.5V
108	TYPEC0_SSTX1P	TYPEC0_TX1P/DP0_TX1P	(Default TYPE-C)	0.5V
109	TYPEC0_SSTX1N	TYPEC0_TX1N/DP0_TX1N	(Default TYPE-C)	0.5V
110	TYPEC0_SSRX2N	TYPEC0_RX2N/DP0_TX2N	(Default TYPE-C)	0.5V
111	TYPEC0_SSRX2P	TYPEC0_RX2P/DP0_TX2P	(Default TYPE-C)	0.5V
112	TYPEC0_SSTX2P	TYPEC0_TX2P/DP0_TX3P	(Default TYPE-C)	0.5V
113	TYPEC0_SSTX2N	TYPEC0_TX2N/DP0_TX3N	(Default TYPE-C)	0.5V
114	GND	Ground		0V
115	MIPI_DPHY1_TX_D0N			0.5V
116	MIPI_DPHY1_TX_D0P			0.5V
117	MIPI_DPHY1_TX_D1N			0.5V
118	MIPI_DPHY1_TX_D1P			0.5V
119	MIPI_DPHY1_TX_CLK N			0.5V
120	MIPI_DPHY1_TX_CLK P			0.5V
121	MIPI_DPHY1_TX_D2N			0.5V
122	MIPI_DPHY1_TX_D2P			0.5V
123	MIPI_DPHY1_TX_D3N			0.5V
124	MIPI_DPHY1_TX_D3P			0.5V
125	GND	Ground		0V
126	RECOVERY_SARADC _VIN1	Program need short to GND when power on.	(PU 10K)	1.8V
127	SARADC_VIN2			1.8V
128	SARADC_VIN5			1.8V
129	GND	Ground		0V
130	MIPI_DPHY1_RX_D0N			0.5V
131	MIPI_DPHY1_RX_D0P			0.5V
132	MIPI_DPHY1_RX_D1N			0.5V
133	MIPI_DPHY1_RX_D1P			0.5V
134	MIPI_DPHY1_RX_CLK N			0.5V



Pin	Signal	Description or functions	GPIO serial	IO Voltage
135	MIPI_DPHY1_RX_CLKP			0.5V
136	MIPI_DPHY1_RX_D2N			0.5V
137	MIPI_DPHY1_RX_D2P			0.5V
138	MIPI_DPHY1_RX_D3N			0.5V
139	MIPI_DPHY1_RX_D3P			0.5V
140	VCC_3V3_S0	3.3V power out (Sleep OFF)	(Max:500mA)	3.3V
141	PHY1_LED2/CFG_LD O1	Ethernet Speed LED	(PD 10K)	3.3V
142	PHY1_LED1/CFG_LD O0	Ethernet Link LED	(PD 10K)	3.3V
143	VCC_RTC	RTC button Cell power input		1.8~3.3V
144	RTC_32KCLK_1V8	32.768kHz output	(GPIO0_B2)(PU 10K)	1.8V
145	DP0_HPDIIN_M1_1V8	UART0_RX_M0/I2C4_SDA_M2/PDM0_CLK_M1/PWM2_M0	GPIO0_C4_d	1.8V
146	GPIO0_D5_u_1V8	I2C1_SDA_M2/CAN2_TX_M1/SATA_MP_SWITCH/HDMI_SCL_M1	GPIO0_D5_u	1.8V
147	GND	Ground		0V
148	PHY1_MDI0+			0.5V
149	PHY1_MDI0-			0.5V
150	PHY1_MDI1+			0.5V
151	PHY1_MDI1-			0.5V
152	PHY1_MDI2+			0.5V
153	PHY1_MDI2-			0.5V
154	PHY1_MDI3+			0.5V
155	PHY1_MDI3-			0.5V
156	GND	Ground		0V
157	MIPI_CSI0_RX_CLK0N	CSI0_RX0_CLKN		0.5V
158	MIPI_CSI0_RX_CLK0P	CSI0_RX0_CLKP		0.5V
159	MIPI_CSI0_RX_D0N	CSI0_RX0_D0N		0.5V
160	MIPI_CSI0_RX_D0P	CSI0_RX0_D0P		0.5V
161	MIPI_CSI0_RX_D1N	CSI0_RX0_D1N		0.5V
162	MIPI_CSI0_RX_D1P	CSI0_RX0_D1P		0.5V
163	MIPI_CSI0_RX_CLK1N	CSI0_RX1_CLKN		0.5V
164	MIPI_CSI0_RX_CLK1P	CSI0_RX1_CLKP		0.5V
165	MIPI_CSI0_RX_D2N	CSI0_RX0_D2N / RX1_D0N		0.5V
166	MIPI_CSI0_RX_D2P	CSI0_RX0_D2P / RX1_D0P		0.5V
167	MIPI_CSI0_RX_D3N	CSI0_RX0_D3N / RX1_D1N		0.5V
168	MIPI_CSI0_RX_D3P	CSI0_RX0_D3P / RX1_D1P		0.5V
169	GND	Ground		0V



Pin	Signal	Description or functions	GPIO serial	IO Voltage
170	I2S0_SDO2/SDI3_1V8	SPI1_MOSI_M2/I2C7_SDA_M0/PDM0_SDI1_M0/UART6_RX_M2	GPIO1_D1_d	1.8V
171	I2S0_SDO1_1V8	SPI1_MISO_M2/I2C7_SCL_M0/UART6_TX_M2	GPIO1_D0_d	1.8V
172	I2S0_SDO0_1V8	I2C4_SCL_M4/UART4_CTS_N_M0	GPIO1_C7_d	1.8V
173	I2S0_LRCK_TX_1V8	I2C2_SCL_M3/UART4_RTS_N_M0	GPIO1_C5_d	1.8V
174	GND	Ground		0V
175	PCIE20_0_REFCLKN			0.5V
176	PCIE20_0_REFCLKP			0.5V
177	PCIE20_0_RXN/SATA3_0_0_RXN	PCIE or SATA interface		0.5V
178	PCIE20_0_RXP/SATA3_0_0_RXP	PCIE or SATA interface		0.5V
179	PCIE20_0_TXN/SATA3_0_0_TXN	PCIE or SATA interface		0.5V
180	PCIE20_0_TXP/SATA3_0_0_TXP	PCIE or SATA interface		0.5V
181	PCIE20_2_REFCLKP			0.5V
182	PCIE20_2_REFCLKN			0.5V
183	PCIE20_2_TXP/SATA3_0_2/USB3_2_TXP	PCIE or SATA interface		0.5V
184	PCIE20_2_TXN/SATA3_0_2/USB3_2_TXN	PCIE or SATA interface		0.5V
185	PCIE20_2_RXP/SATA3_0_2/USB3_2_RXP	PCIE or SATA interface		0.5V
186	PCIE20_2_RXN/SATA3_0_2/USB3_2_RXN	PCIE or SATA interface		0.5V
187	GND	Ground		0V
188	I2S0_SDO3/SDI2_1V8	SPI1_CLK_M2/I2C1_SCL_M4/PDM0_SDI2_M0/UART4_TX_M0/PWM0_M1	GPIO1_D2_d	1.8V
189	I2S0_SDI1_1V8	SPI1_CS0_M2/I2C1_SDA_M4/PDM0_SDI3_M0/UART4_RX_M0/PWM1_M1	GPIO1_D3_d	1.8V
190	I2S0_SDI0_1V8		GPIO1_D4_d	1.8V
191	I2S0_SCLK_TX_1V8	SPI4_CS0_M0/I2C6_SCL_M1/UART3_CTSN_M0	GPIO1_C3_d/PWM7_IR_M2	1.8V
192	I2S0_MCLK_1V8	SPI4_CLK_M0/I2C6_SDA_M1/UART3_RTSN_M0	GPIO1_C2_d/PWM3_IR_M2	1.8V

Pin	Signal	Description or functions	GPIO serial	IO Voltage
193	I2C3_SDA_M0_1V8	SPI4_MISO_M0/UART3_RX_M0	GPIO1_C0_z (PU2.2K)	1.8V
194	I2C3_SCL_M0_1V8	SPI4_MOSI_M0/UART3_TX_M0	GPIO1_C1_z (PU2.2K)	1.8V
195	I2C5_SDA_M3_1V8	UART1_RX_M1/SPDIF1_TX_M0/CAMERA2_CLK_M0/SATA2_ACT_LED_M1	GPIO1_B7_u /PWM13_M2 (PU2.2K)	1.8V
196	I2C5_SCL_M3_1V8	UART1_TX_M1/SPDIF0_TX_M0/CAMERA1_CLK_M0	GPIO1_B6_u (PU2.2K)	1.8V

1.7 Development Kit (Idea3588S)

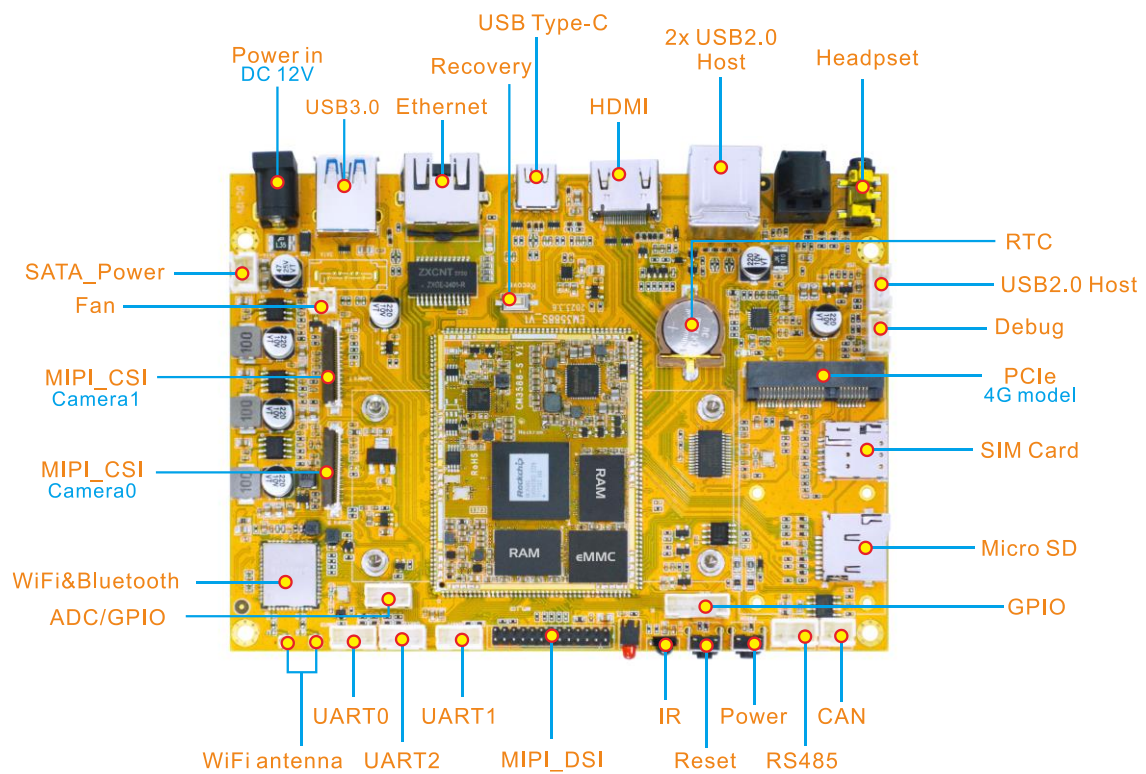



2 Hardware Design Guide

2.1 Peripheral Circuit Reference

2.1.1 External Power

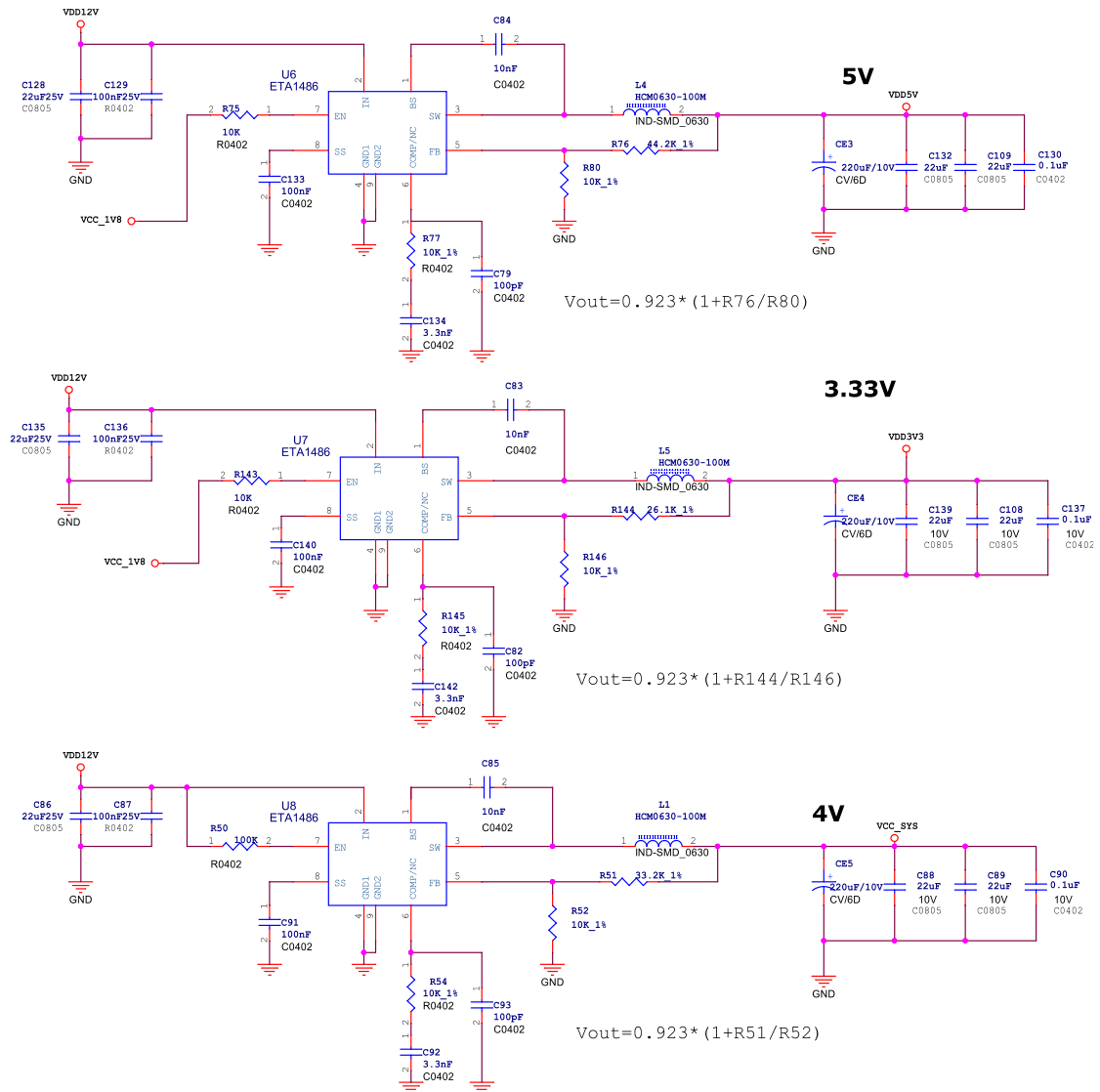

2.1.2 Debug Circuit

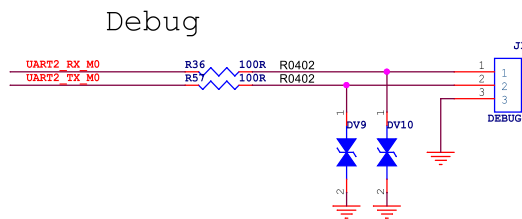



2.1.3 HDMI0 TX Circuit

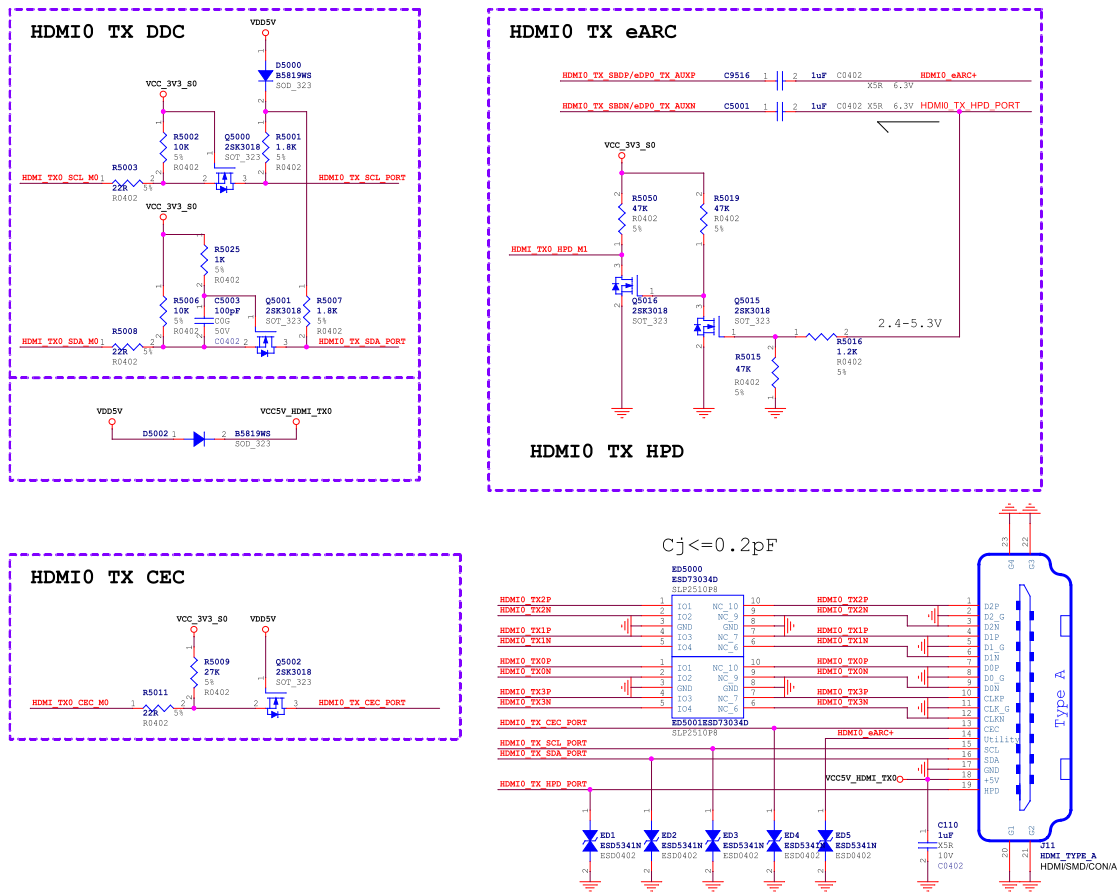

2.2 Mother Board length offset

2.2.1 MIPI CSI0 4-Lane Interface length offset

MIPI_CSI0_RX0_CLKP	MIPI_CSI0_RX0_D0P	(5.929)	
	MIPI_CSI0_RX0_D1P	(5.787)	
	MIPI_CSI0_RX0_D2P	(258.716)	(+230)
	MIPI_CSI0_RX0_D3P	(256.734)	(+230)

Yellow block is CM3588S CSI0 group length difference.

Unit: mil

2.2.2 MIPI DPHY1 4-Lane Interface length offset

MIPI_DPHY_TX1_CLKP	MIPI_DPHY_TX1_D0P	(-87.504)	-65
	MIPI_DPHY_TX1_D1P	(-44.027)	-25
	MIPI_DPHY_TX1_D2P	(9.937)	
	MIPI_DPHY_TX1_D3P	(0.575)	

Yellow block is CM3588S DSI1 group length difference.

Unit: mil

2.3 PCB Footprint

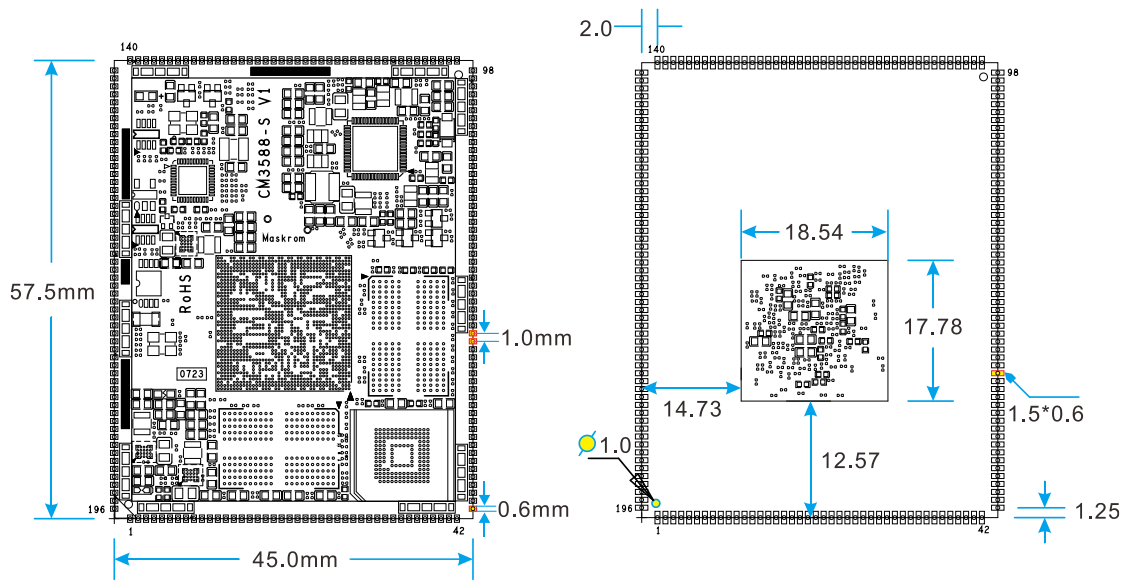

3 Product Electrical Characteristics

3.1 Dissipation and Temperature

Symbol	Parameter	Min	Typ	Max	Unit
VCC_SYS	System Voltage	3.4V	4	4.5	V
I _{sys_in}	VCC_SYS input Current		2050	3350	mA
VCC_RTC	RTC Voltage	1.8	3	3.4	V
I _{irtc}	RTC input Current		5	8	uA
I _{3v3_out}	VCC_3V3 output Current			500	mA
I _{1v8_out}	VCC_1V8 output Current			500	mA
T _a	Operating Temperature	0		70	°C



Tstg	Storage Temperature	-40		85	°C
------	---------------------	-----	--	----	----

3.2 Reliability of Test

High Temperature Operating Test		
Contents	Operating 8h in high temperature	55°C±2°C
Result	TBD	

Operating Life Test		
Contents	Operating in room	120h
Result	TBD	