

Compact3566 User Manual

V2. 202212



Boardcon Embedded Design

www.boardcon.com

1. Introduction

1.1. About this Manual

This manual is intended to provide the user with an overview of the board and benefits, complete features specifications, and set up procedures. It contains important safety information as well.

1.2. Feedback and Update to this Manual

To help our customers make the most of our products, we are continually making additional and updated resources available on the Boardcon website (www.boardcon.com , www.armdesigner.com).

These include manuals, application notes, programming examples, and updated software and hardware. Check in periodically to see what's new!

When we are prioritizing work on these updated resources, feedback from customers is the number one influence, if you have questions, comments, or concerns about your product or project, please no hesitate to contact us at support@armdesigner.com.

1.3. Limited Warranty

Boardcon warrants this product to be free of defects in material and workmanship for a period of one year from date of buy. During this warranty period Boardcon will repair or replace the defective unit in accordance with the following process:

A copy of the original invoice must be included when returning the defective unit to Boardcon. This limited warranty does not cover damages resulting from lightning or other power surges, misuse, abuse, abnormal conditions of operation, or attempts to alter or modify the function of the product.

This warranty is limited to the repair or replacement of the defective unit. In no event shall Boardcon be liable or responsible for any loss or damages, including but not limited to any lost profits, incidental or consequential damages, loss of business, or anticipatory profits arising from the use or inability to use this product.

Repairs make after the expiration of the warranty period are subject to a repair charge and the cost of return shipping. Please contact Boardcon to arrange for any repair service and to obtain repair charge information.



Content

1 Compact3566 Introduction	3
1.1 Summary	3
1.2 Features.....	3
1.3 RK3566 Block Diagram.....	5
1.4 Compact3566 PCB Dimension	6
1.5 Compact3566 Pin Definition	6
1.6 Compact3566 Functions Marker	7
2 Hardware Design Guide.....	9
2.1 Connector Circuit	9
2.2 PCBA mechanical	11
3 Product Electrical Characteristics	12
3.1 Dissipation and Temperature	12
3.2 Reliability of Test	12

1 Compact3566 Introduction

1.1 Summary

The Compact3566 is mini single board computer based on Rockchip's RK3566. It has quad-core Cortex-A55, Mali-G52 GPU, and 1 TOPs NPU. It supports 4K video decode.

It is designed specifically for the AIoT devices such as industrial controller, IoT devices, intelligent interactive devices, personal computers and robots. The high performance and low power solution can help customers to introduce new technologies more quickly and enhance the overall solution efficiency.

1.2 Features

- **Microprocessor**
 - Quad-core Cortex-A55 up to 1.8G
 - 32KB I-cache and 32KB D-cache for each core, 512KB L3 cache
 - 1 TOPS Neural Process Unit
 - Mali-G52 up to 0.8G
- **Memory Organization**
 - LPDDR4 RAM up to 8GB
 - EMMC up to 128GB
- **Boot ROM**
 - Supports system code download through USB OTG or SD
- **Trust Execution Environment system**
 - Supports secure OTP and multiple cipher engine
- **Video Decoder/Encoder**
 - Supports video decoding up to 4K@60fps
 - Supports H.264 encode
 - H.264 HP encoding up to 1080p@60fps
 - Picture size up to 8192x8192
- **Display Subsystem**
 - **Video Output**

Supports HDMI 2.0 transmitter with HDCP 1.4/2.2, up to 4K@60fps

Supports 4 lanes MIPI DSI up to 2560x1440@60Hz

Or LVDS interface up to 1920x1080@60Hz
 - **Image in**

Supports MIPI CSI 2lanes interface
- **Audio**
 - Headphone stereo output and MIC input
 - Support MIC array Up to 4ch PDM/TDM interface
 - Support I2S/PCM interface
 - One SPDIF output



- **USB and PCIE**
 - Three 2.0 USB interfaces
 - One USB 2.0 OTG, and two 2.0 USB hosts
 - One USB 3.0 host
 - One PCIE or SATA interface for M.2 SSD.
- **Ethernet**
 - Support 10/100/1000Mbit/s data transfer rates
- **I2C**
 - Up to two I2Cs
 - Support standard mode and fast mode (up to 400kbit/s)
- **SD**
 - Support Micro SD Card
- **SPI**
 - Up to two SPI controllers,
 - Full-duplex synchronous serial interface
- **UART**
 - Support up to Four user UARTs
 - Debug UART via micro-USB
- **ADC**
 - ADC key in Headphone
- **PWM**
 - Support 10 PWMs
 - Support 32bit time/counter facility
 - IR option on PWM3/7/15
- **Power unit**
 - Single 5V@2A input
 - CR1220 button Cell for RTC
 - Support 5V PoE+ power module



1.3 RK3566 Block Diagram

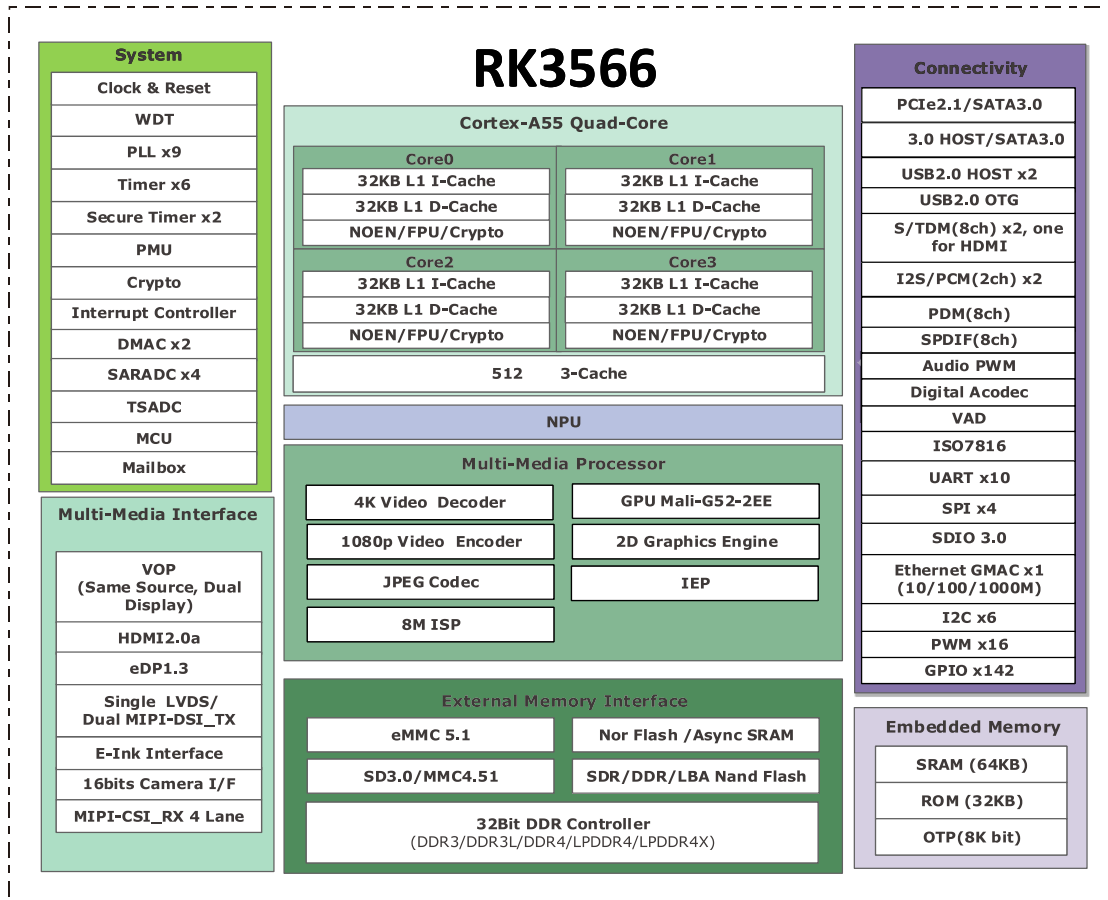



1.4 Compact3566 PCB Dimension

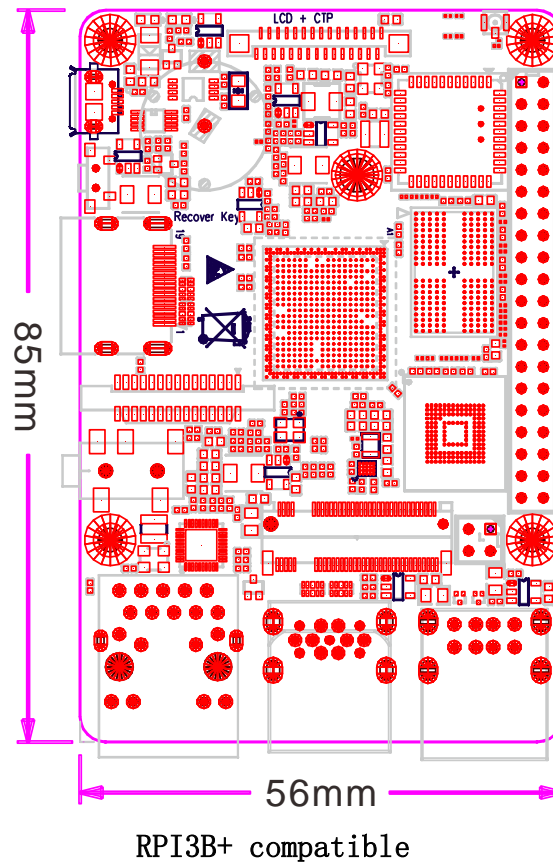

1.5 Compact3566 Pin Definition

GPIO	Signal	Description or functions	GPIO serial	IO Voltage
1	VCC3V3_SYS	3.3V IO Power output(Max:0.5A)		3.3V
2	VCC5V_SYS	5V Main Power input		5V
3	I2C3_SDA_M0	PU 2.2K/ UART3_RX_M0	GPIO1_A0_u	3.3V
4	VCC5V_SYS	5V Main Power input		5V
5	I2C3_SCL_M0	PU 2.2K/ UART3_TX_M0	GPIO1_A1_u	3.3V
6	GND	Ground		0V
7	GPIO0_A3_u			3.3V
8	GPIO3_C2_d	UART5_TX_M1		3.3V
9	GND	Ground		0V
10	GPIO3_C3_d	UART5_RX_M1		3.3V
11	GPIO1_B1_d	PDM_SD12_M0 (V2 exchanged)		3.3V
12	GPIO4_C3_d	SPI3_MOSI_M1/I2S3_SCLK_M1 (V2 exchanged)	PWM15_IR_M1	3.3V
13	GPIO0_A5_d			3.3V



GPIO	Signal	Description or functions	GPIO serial	IO Voltage
14	GND	Ground		0V
15	GPIO0_A6_d			3.3V
16	GPIO0_B7_d	PWM0_M0		3.3V
17	VCC3V3_SYS	3.3V IO Power output(Max:0.5A)		3.3V
18	GPIO0_C2_d	PWM3_IR		3.3V
19	GPIO0_B6_u	SPI0_MOSI_M0/ I2C2_SDA_M0	PWM2_M1	3.3V
20	GND	Ground		0V
21	GPIO0_C5_d	SPI0_MISO_M0	PWM6	3.3V
22	GPIO0_A0_d	REFCLK_OUT		3.3V
23	GPIO0_B5_u	SPI0_CLK_M0/ I2C2_SCL_M0	PWM1_M1	3.3V
24	GPIO0_C6_d	SPI0_CS0_M0	PWM7_IR	3.3V
25	GND	Ground		0V
26	GPIO0_C4_d	SPI0_CS1_M0	PWM5	3.3V
27	I2C1_SDA	PU 2.2K	(Note1)	3.3V
28	I2C1_SCL	PU 2.2K	(Note1)	3.3V
29	GPIO1_A6_d	UART4_TX_M0/PDMCLK0_M0 (V2 exchanged)		3.3V
30	GND	Ground		0V
31	GPIO1_A4_d	UART4_RX_M0/PDMCLK1_M0 (V2 exchanged)		3.3V
32	GPIO0_C7_d	(V2 exchange)	PWM0_M1	3.3V
33	GPIO4_C2_d	SPI3_CLK_M1/I2S3_MCLK_M1 (V2 exchanged)	PWM14_M1	3.3V
34	GND	Ground		0V
35	GPIO4_C4_d	SPDIF_TX_M2/I2S3_LRCK_M1/ SATA2_ACT_LED (V2 exchanged)		3.3V
36	GPIO4_D1_u	SPI3_CS1_M1(V2-1208 update)	(Note2)	3.3V
37	GPIO1_B2_d	PDM_SDI1_M0 (V2 exchanged)		3.3V
38	GPIO4_C6_d	UART9_RX_M1/SPI3_CS0_M1/ I2S3_SDI_M1 (V2 exchanged)	PWM13_M1	3.3V
39	GND	Ground		0V
40	GPIO4_C5_d	UART9_TX_M1/SPI3_MISO_M1 /I2S3_SDO_M1 (V2 exchanged)	PWM12_M1	3.3V

Note:

1. I2C1 can't be used for exclusive bus, Such as CTP.
2. Pin36 will change to GPIO3_C1_d next version(V3).

1.6 Compact3566 Functions Marker

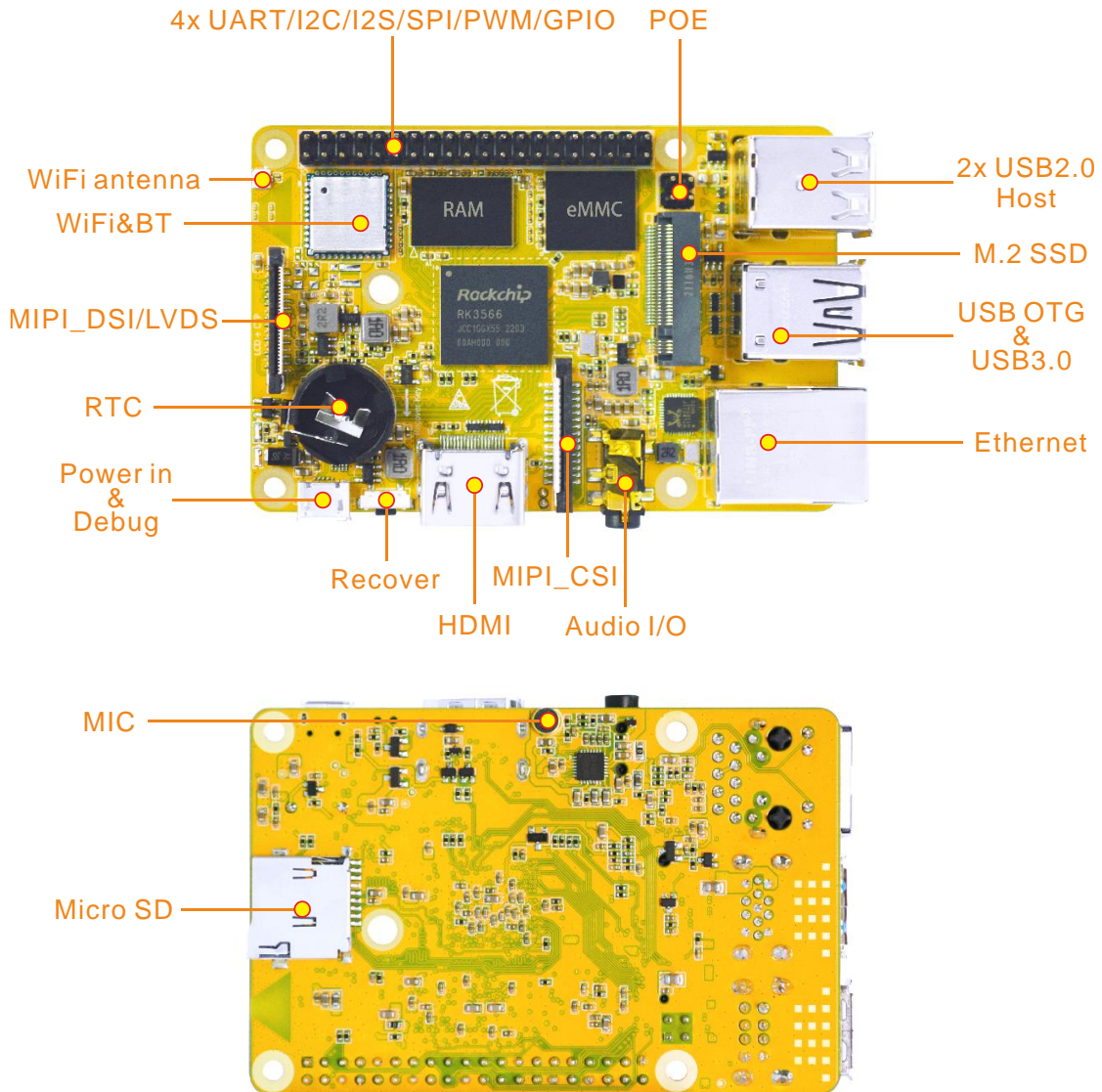



2 Hardware Design Guide

2.1 Connector Circuit

2.1.1 USB Host

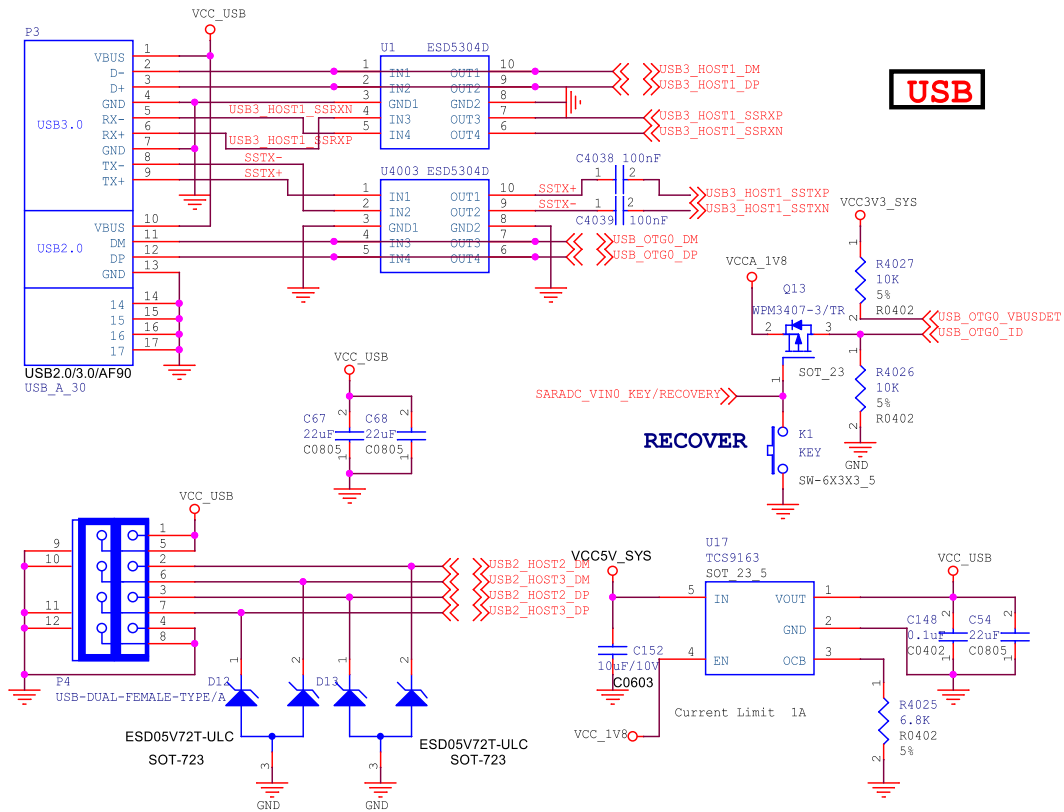

2.1.2 Debug Circuit

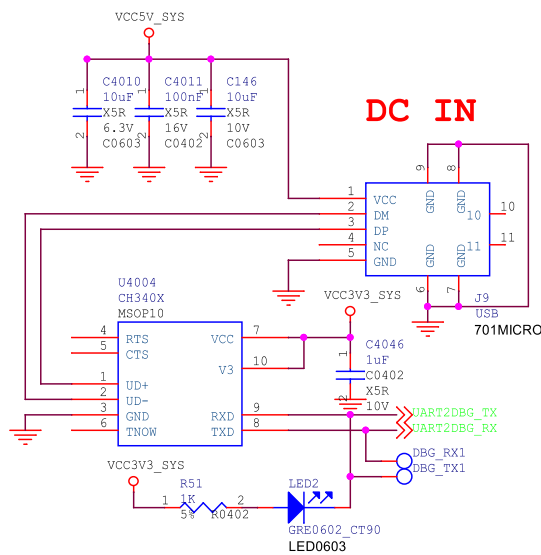

2.1.3 Headphone Circuit

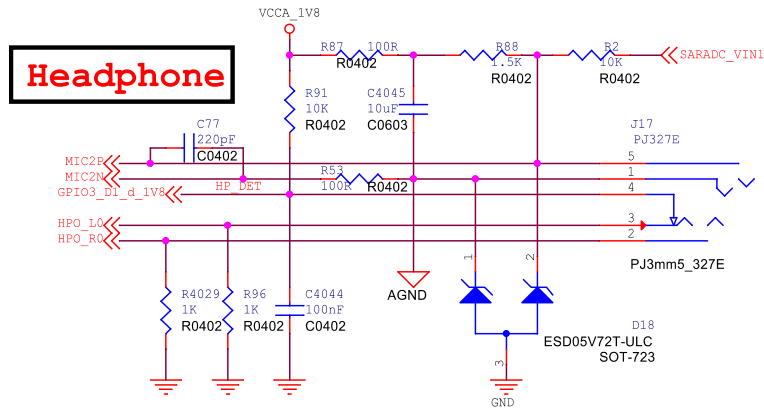

2.1.4 Camera and LCD Circuit

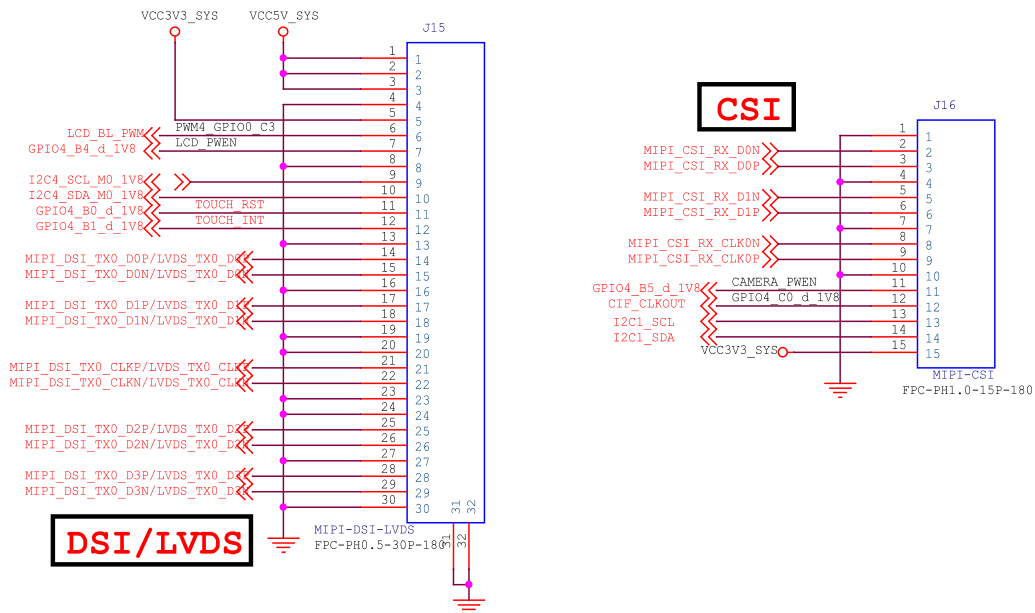

2.1.5 GPIO Circuit

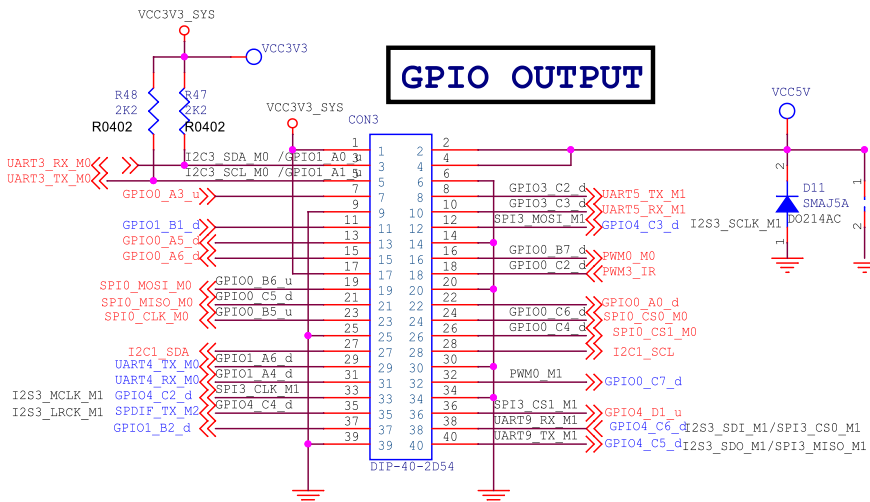



2.1.6 POE Circuit

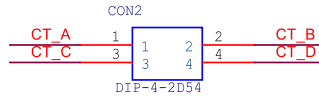

2.2 PCBA mechanical

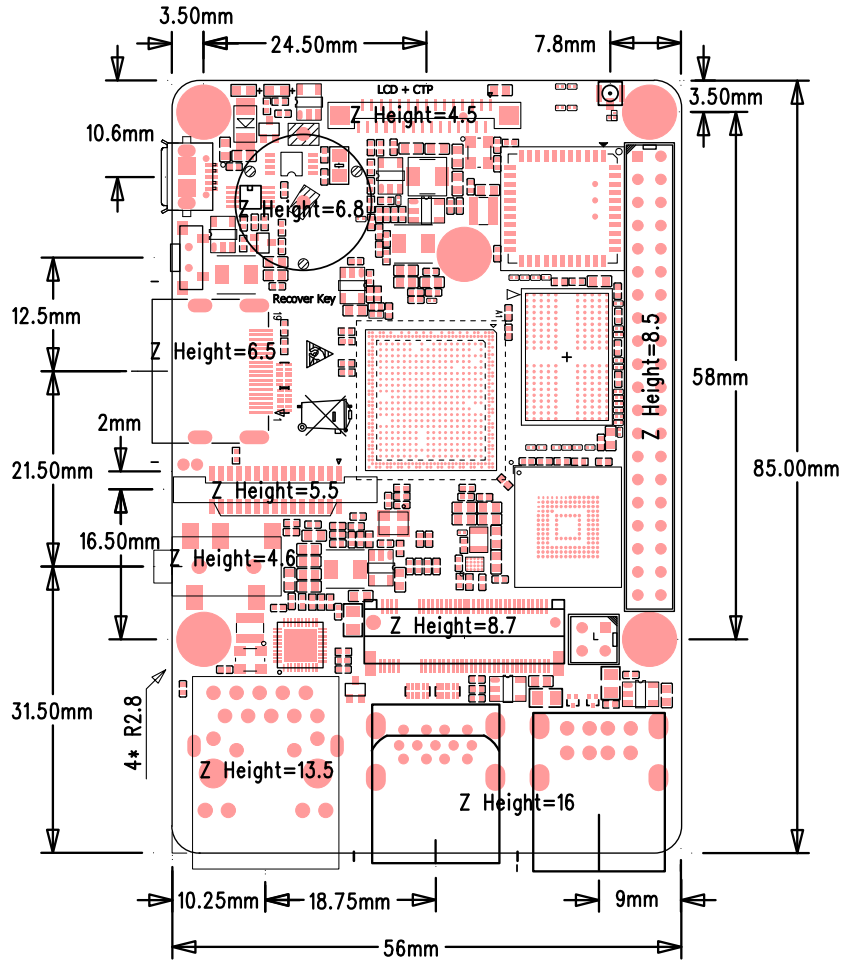



3 Product Electrical Characteristics

3.1 Dissipation and Temperature

Symbol	Parameter	Min	Typ	Max	Unit
VCC50_SYS	Main Power Voltage	5-5%	5	5+5%	V
I _{sys_in}	VCC5V_SYS input Current		820		mA
VCC_RTC	RTC Voltage	1.8	3	3.4	V
I _{rtc}	RTC input Current		5	8	uA
T _a	Operating Temperature	-0		70	°C
T _{stg}	Storage Temperature	-40		85	°C

3.2 Reliability of Test

Low Temperature Operating Test		
Contents	Operating 4h in Low temperature	-20°C±2°C
Result	pass	
High Temperature Operating Test		
Contents	Operating 8h in high temperature	65°C±2°C
Result	pass	
Operating Life Test		
Contents	Operating in room	120h
Result	pass	