

Mini1126 Reference User Manual

V1.1 20230906

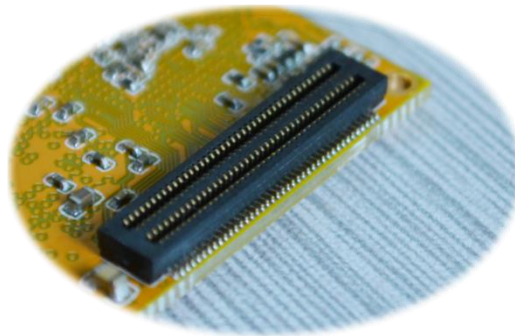
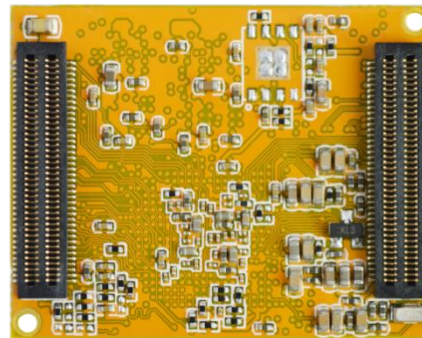
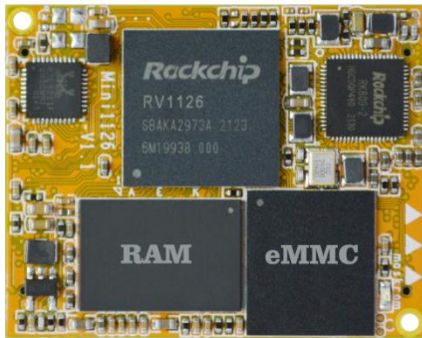

Boardcon Embedded Design

www.armdesigner.com

1. Introduction

1.1. About this Manual

This manual is intended to provide the user with an overview of the board and benefits, complete features specifications, and set up procedures. It contains important safety information as well.

1.2. Feedback and Update to this Manual

To help our customers make the most of our products, we are continually making additional and updated resources available on the Boardcon website (www.boardcon.com , www.armdesigner.com).

These include manuals, application notes, programming examples, and updated software and hardware. Check in periodically to see what's new!

When we are prioritizing work on these updated resources, feedback from customers is the number one influence, If you have questions, comments, or concerns about your product or project, please no hesitate to contact us at support@armdesigner.com.

1.3. Limited Warranty

Boardcon warrants this product to be free of defects in material and workmanship for a period of one year from date of buy. During this warranty period Boardcon will repair or replace the defective unit in accordance with the following process:

A copy of the original invoice must be included when returning the defective unit to Boardcon. This limited warranty does not cover damages resulting from lightning or other power surges, misuse, abuse, abnormal conditions of operation, or attempts to alter or modify the function of the product.

This warranty is limited to the repair or replacement of the defective unit. In no event shall Boardcon be liable or responsible for any loss or damages, including but not limited to any lost profits, incidental or consequential damages, loss of business, or anticipatory profits arising from the use or inability to use this product.

Repairs make after the expiration of the warranty period are subject to a repair charge and the cost of return shipping. Please contact Boardcon to arrange for any repair service and to obtain repair charge information.



Content

1 Mini1126 Introduction	3
1.1 Summary	3
1.2 Features.....	3
1.3 Block Diagram.....	5
1.4 Specifications.....	6
1.5 PCB Dimension.....	7
1.6 Pin Definition.....	7
1.7 Development Kit (EM1126)	12
2 Hardware Design Guide.....	13
2.1 Peripheral Circuit Reference	13
2.2 PCB Footprint	15
2.3 B2B connector for carrier board	16
3 Product Electrical Characteristics	17
3.1 Dissipation and Temperature	17

1 Mini1126 Introduction

1.1 Summary

The Mini1126 system-on-module is equipped with Rockchip's RV1126 build in quad-core Cortex-A7, 2.0 TOPs NPU and RISC-V MCU.

It is designed specifically for the IPC/CVR devices, AI Camera devices, intelligent interactive devices, and mini robots. The high performance and low power solution can help customers to introduce new technologies more quickly and enhance the overall solution efficiency.

1.2 Features

- **Microprocessor**
 - Quad-core Cortex-A7 up to 1.5G
 - 32KB I-cache and 32KB D-cache for each core, 512KB L2 cache
 - 2.0 TOPS Neural Process Unit
 - RISC-V MCU to support 250mS fast boot
 - Max 14M ISP
- **Memory Organization**
 - LPDDR4 RAM up to 4GB
 - EMMC up to 32GB
 - SPI Flash up to 8MB
- **Video Decoder/Encoder**
 - Supports video decode/encode up to 4K@30fps
 - Supports real-time decoding of H.264/265
 - Supports real-time UHD H.264/265 video encoding
 - Picture size up to 8192x8192
- **Display Subsystem**
 - **Video Output**
 - Supports 4 lanes MIPI DSI up to 1080P@60fps
 - Supports 24bit RGB parallel output
 - **Image in**
 - Supports up to 16bit DVP interface
 - Supports 2ch MIPI CSI 4lanes interface
- **I2S/PCM/ AC97**
 - Two I2S/PCM interface
 - Support Mic array Up to 8ch PDM/TDM interface
 - Support PWM audio output
- **USB and PCIE**
 - Two 2.0 USB interfaces
 - One USB 2.0 OTG, and one 2.0 USB hosts
- **Ethernet**



- RTL8211F onboard
- Support 10/100/1000M
- **I2C**
 - Up to five I2C
 - Support standard mode and fast mode(up to 400kbit/s)
- **SDIO**
 - Support 2CH SDIO 3.0 protocol
- **SPI**
 - Up to two SPI controllers,
 - Full-duplex synchronous serial interface
- **UART**
 - Support up to 6 UARTs
 - UART2 with 2 wires for debug tools
 - Embedded two 64byte FIFO
 - Support auto flow control mode for UART1-5(except UART2)
- **ADC**
 - Up to three ADC channels
 - 10-bit resolution
 - Voltage input range between 0V to 1.8V
 - Support up to 1MS/s sampling rate
- **PWM**
 - 11 on-chip PWMs with interrupt-based operation
 - Support 32bit time/counter facility
 - IR option on PWM3/7
- **Power unit**
 - RK809 on board
 - 5V input and RTC power input
 - Build-in Audio Codec



1.3 Block Diagram

1.3.1 RV1126 Block Diagram

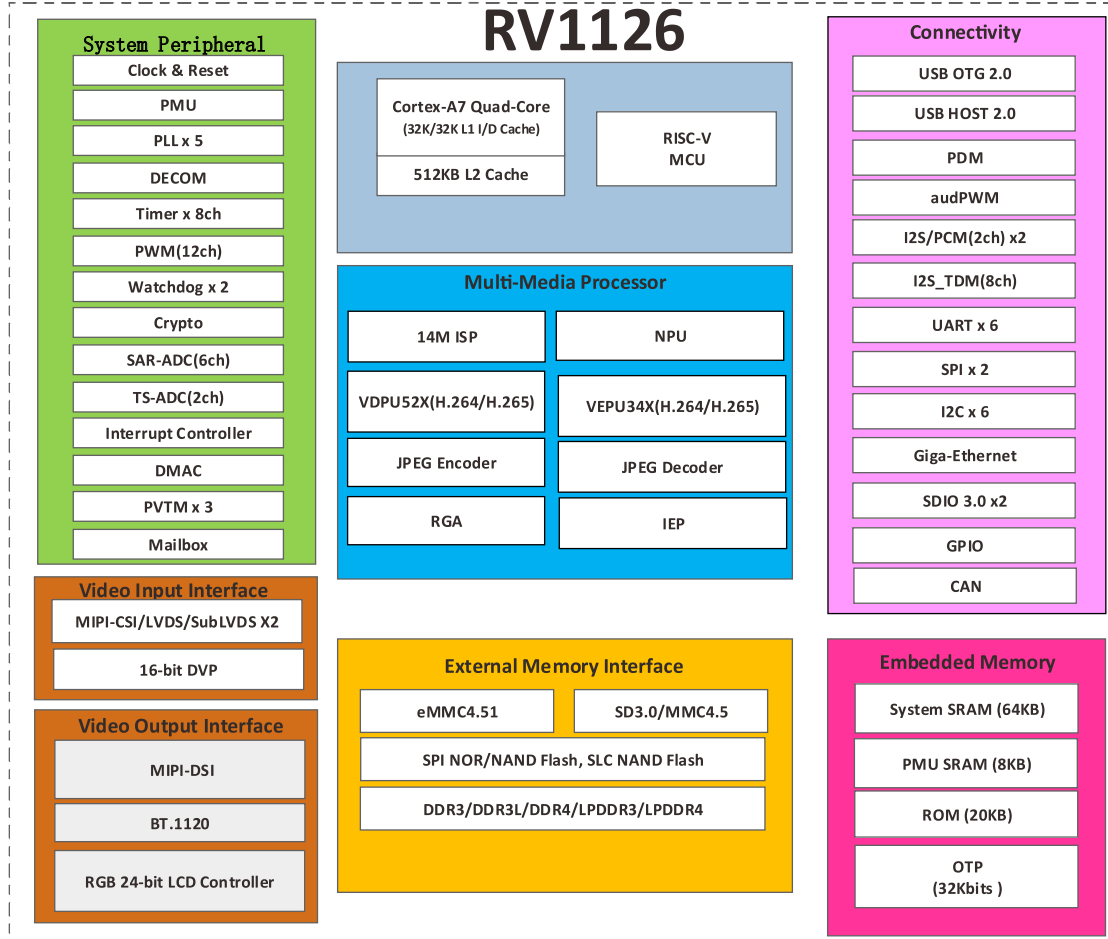



1.3.2 Development board (EM1126) Block Diagram

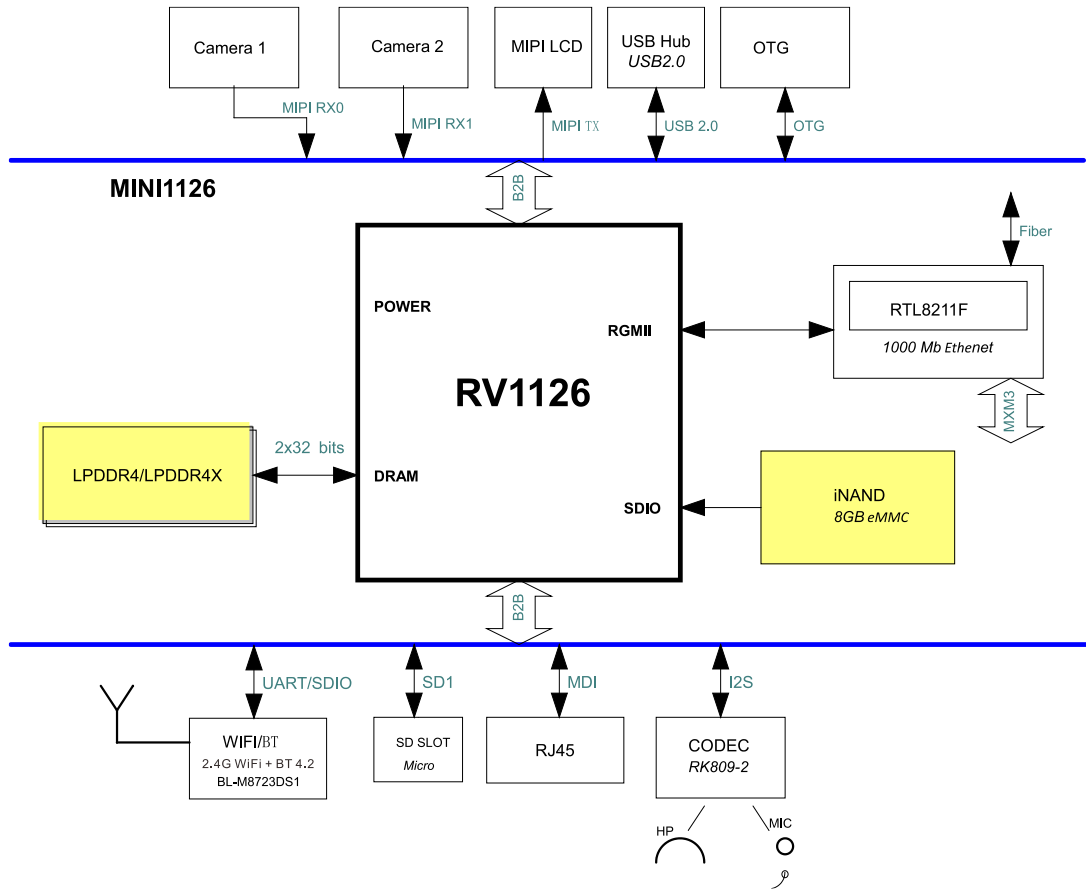

1.4 Specifications

Feature	Specifications
CPU	Quad-core Cortex-A7
DDR	2GB LPDDR4 (up to 4GB)
eMMC FLASH	8GB (up to 32GB)
Power	DC 5V
MIPI DSI	4-Lane
I2S	3-CH
MIPI CSI	4-Lane
RGB LCD	24bit
Camera	1-CH(DVP) and 2-CH(CSI)
USB	2-CH (USB HOST2.0 and OTG 2.0)
Ethernet	1000M GMAC
SDMMC	2-CH
I2C	5-CH
SPI	2-CH



UART	5-CH, 1-CH(DEBUG)
PWM	11-CH
ADC IN	3-CH
Board Dimension	30 x 38mm

1.5 PCB Dimension

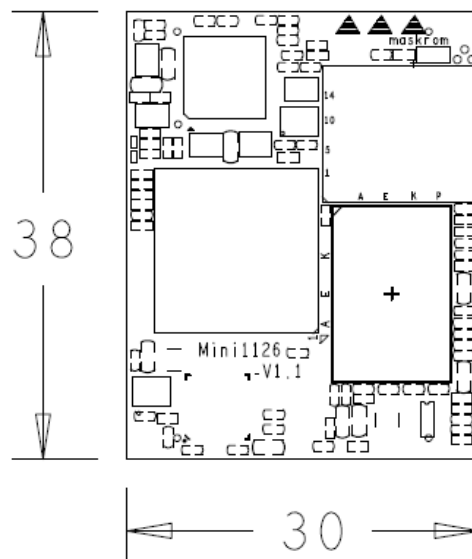

1.6 Pin Definition

J1	Signal	Description or functions	GPIO serial	IO Voltage
1	VCC5V0_SYS	5V Main Power input		5V
2	VCC5V0_SYS	5V Main Power input		5V
3	VCC5V0_SYS	5V Main Power input		5V
4	VCC5V0_SYS	5V Main Power input		5V
5	GND	Ground		0V
6	SNSP	Charge sense current signal in		0V
7	GND	Ground		0V
8	SNSN	Charge sense current signal in		0V
9	CLKO_32K	RTC clock output		1.8V
10	GND	Ground		0V
11	PWRON	Power key input		5V
12	BATDIV	Divided voltage of positive BATT		3.3V
13	MIC_L	Microphone L-CH or positive in		0V
14	VCC_RTC	RTC Power input		3.3V



J1	Signal	Description or functions	GPIO serial	IO Voltage
15	MIC_R	Microphone R-CH or negative in		0V
16	SDMMC0_CLK	UART3_RTSn_M1	GPIO1_B0_u	3.3V
17	GND	Ground		0V
18	SDMMC0_CMD	UART3_CTSn_M1	GPIO1_B1_u	3.3V
19	HPR_OUT	R-CH output of headphone		0V
20	SDMMC0_D0	UART2_RX_M0	GPIO1_A4_u	3.3V
21	HP_SNS	Reference ground of headphone		0V
22	SDMMC0_D1	UART2_TX_M0	GPIO1_A5_u	3.3V
23	HPL_OUT	L-CH output of headphone		0V
24	SDMMC0_D2	UART3_RX_M1	GPIO1_A6_u	3.3V
25	I2C1_SDA	UART4_RTSn_M2	GPIO1_D2_u	1.8V
26	SDMMC0_D3	UART3_TX_M1	GPIO1_A7_u	3.3V
27	I2C1_SCL	UART4_CTSn_M2	GPIO1_D3_u	1.8V
28	I2C2_SDA_3V3	PWM5_M0	GPIO0_C3_d	3.3V
29	MIPI_CSI_CLK0	UART5_CTSn_M2	GPIO2_A3_d	1.8V
30	I2C2_SCL_3V3	PWM4_M0	GPIO0_C2_d	3.3V
31	GND	Ground		0V
32	MIPI_CSI_PWDN0	UART4_RX_M2	GPIO1_D4_d	1.8V
33	MIPI_CSI_CLK1	UART5_RTSn_M2	GPIO2_A2_d	1.8V
34	MIPI_CSI_RX1_D0 N	MIPI CSI1 or LVDS1 RXD0N		1.8V
35	MIPI_CSI_RX1_D1 N	MIPI CSI1 or LVDS1 RXD1N		1.8V
36	MIPI_CSI_RX1_D0 P	MIPI CSI1 or LVDS1 RXD0P		1.8V
37	MIPI_CSI_RX1_D1 P	MIPI CSI1 or LVDS1 RXD1P		1.8V
38	GND	Ground		0V
39	MIPI_CSI_RX1_D2 N	MIPI CSI1 or LVDS1 RXD2N		1.8V
40	MIPI_CSI_RX1_CL KN	MIPI CSI1 or LVDS1 CLKN		1.8V
41	MIPI_CSI_RX1_D2 P	MIPI CSI1 or LVDS1 RXD2P		1.8V
42	MIPI_CSI_RX1_CL KP	MIPI CSI1 or LVDS1 CLKP		1.8V
43	MIPI_CSI_RX1_D3 N	MIPI CSI1 or LVDS1 RXD3N		1.8V
44	UART1_RX_3V3	PWM1_M0	GPIO0_B7_d	3.3V
45	MIPI_CSI_RX1_D3 P	MIPI CSI1 or LVDS1 RXD3P		1.8V
46	UART1_TX_3V3	PWM0_M0	GPIO0_B6_d	3.3V



J1	Signal	Description or functions	GPIO serial	IO Voltage
47	WIFI_REG_ON	SPI0_MOSI_M0	GPIO0_A6_d	1.8V
48	SDMMC0_DET	Must be used for SD Card	GPIO0_A3_u	1.8V
49	BT_RST	SPI0_MISO_M0	GPIO0_A7_d	1.8V
50	BT_WAKE	SPI0_CS1n_M0	GPIO0_A4_u	1.8V
51	WIFI_WAKE_HOST	SPI0_CLK_M0	GPIO0_B0_d	1.8V
52	BT_WAKE_HOST	SPI0_CS0n_M0	GPIO0_A5_u	1.8V
53	MIPI_CSI_RX0_D0 N	MIPI CSI0 or LVDS0 RXD0N		1.8V
54	MIPI_CSI_RX0_D2 N	MIPI CSI0 or LVDS0 RXD2N		1.8V
55	MIPI_CSI_RX0_D0 P	MIPI CSI0 or LVDS0 RXD0P		1.8V
56	MIPI_CSI_RX0_D2 P	MIPI CSI0 or LVDS0 RXD2P		1.8V
57	MIPI_CSI_RX0_D1 N	MIPI CSI0 or LVDS0 RXD1N		1.8V
58	MIPI_CSI_RX0_D3 N	MIPI CSI0 or LVDS0 RXD3N		1.8V
59	MIPI_CSI_RX0_D1 P	MIPI CSI0 or LVDS0 RXD1P		1.8V
60	MIPI_CSI_RX0_D3 P	MIPI CSI0 or LVDS0 RXD3P		1.8V
61	GND	Ground		0V
62	MIPI_CSI_RX0_CL KN	MIPI CSI0 or LVDS0 CLKN		1.8V
63	PDM_CLK	I2S0_LRCK_RX_M0	GPIO3_D4_d	1.8V
64	MIPI_CSI_RX0_CL KP	MIPI CSI0 or LVDS0 CLKP		1.8V
65	SPI0_CLK_M1	I2S1_SDO_M1/UART5_RX_M2	GPIO2_A1_d	1.8V
66	SPI0_CS0n_M1	I2S1_SDI_M1/UART5_TX_M2	GPIO2_A0_d	1.8V
67	SPI0_MISO_M1	I2S1_LRCK_M1/I2C3_SDA_M2	GPIO1_D7_d	1.8V
68	SPI0_CS1n_M1	I2S1_MCK_M1/UART4_TX_M2	GPIO1_D5_d	1.8V
69	SPI0_MOSI_M1	I2S1_SCK_M1/I2C3_SCL_M2	GPIO1_D6_d	1.8V
70	PDM_SDI0	I2S0_SDI0_M0	GPIO3_D6_d	1.8V
71	PDM_SDI1	I2S0_SDO3_SDI1_M0/I2C4SDA	GPIO4_A1_d	1.8V
72	PDM_SDI2	I2S0_SDO2_SDI2_M0/I2C4SCL	GPIO4_A0_d	1.8V
73	PDM_CLK1	I2S0_LRCK_RX_M0	GPIO3_D4_d	1.8V
74	OTG_ID			1.8V
75	OTG_DET_1V8			1.8V
76	USB_CTRL	Must be use for OTG compatible	GPIO0_C1_d	3.3V
77	OTG_DM			1.8V
78	USB_HOST_DM			1.8V



J1	Signal	Description or functions	GPIO serial	IO Voltage
79	OTG_DP			1.8V
80	USB_HOST_DP			1.8V

J2	Signal	Description or functions	GPIO serial	IO Voltage
1	GND	Ground		0V
2	LCDC_D0_3V3	UART4_RTSn_M1/CIF_D0_M1	GPIO2_A4_d	3.3V
3	LCDC_D16_3V3	CIF_D12_M1	GPIO2_C4_d	3.3V
4	LCDC_D1_3V3	UART4_CTSn_M1/CIF_D1_M1	GPIO2_A5_d	3.3V
5	LCDC_D17_3V3	CIF_D13_M1	GPIO2_C5_d	3.3V
6	LCDC_D2_3V3	UART4_TX_M1/CIF_D2_M1	GPIO2_A6_d	3.3V
7	LCDC_D18_3V3	CIF_D14_M1	GPIO2_C6_d	3.3V
8	LCDC_D3_3V3	UART4_RX_M1/I2S2_SDO_M1	GPIO2_A7_d	3.3V
9	LCDC_D19_3V3	I2S1_MCLK_M2/CIF_D15_M1	GPIO2_C7_d	3.3V
10	LCDC_D4_3V3	UART5_TX_M1/I2S2_SDI_M1	GPIO2_B0_d	3.3V
11	LCDC_D20_3V3	I2S1_SDO_M2/CIF_VS_M1	GPIO2_D0_d	3.3V
12	LCDC_D5_3V3	UART5_RX_M1/I2S2_SCK_M1	GPIO2_B1_d	3.3V
13	LCDC_D21_3V3	I2S1_SCLK_M2/CIF_CLKO_M1	GPIO2_D1_d	3.3V
14	LCDC_D6_3V3	UART5_RTSn_M1/I2S2_LRCK_M1	GPIO2_B2_d	3.3V
15	LCDC_D22_3V3	I2S1_LRCK_M2/CIF_CKIN_M1	GPIO2_D2_d	3.3V
16	LCDC_D7_3V3	UART5_CTSn_M1/I2S2_MCLK_M1/CIF_D3_M1	GPIO2_B3_d	3.3V
17	LCDC_D23_3V3	I2S1_SDI_M2/CIF_HS_M1	GPIO2_D3_d	3.3V
18	LCDC_D8_3V3	CIF_D4_M1	GPIO2_B4_d	3.3V
19	UART0_TX		GPIO1_C3_u	1.8V
20	LCDC_D9_3V3	CIF_D5_M1	GPIO2_B5_d	3.3V
21	UART0_RX		GPIO1_C2_u	1.8V
22	LCDC_D10_3V3	CIF_D6_M1	GPIO2_B6_d	3.3V
23	UART0_RTSEN		GPIO1_C0_u	1.8V
24	LCDC_D11_3V3	CIF_D7_M1	GPIO2_B7_d	3.3V
25	UART0_CTSN		GPIO1_C1_u	1.8V
26	LCDC_D12_3V3	CIF_D8_M1	GPIO2_C0_d	3.3V
27	CAN_RX_3V3	UART3_TX_M2/I2C4_SCL_M0	GPIO3_A0_u	3.3V
28	LCDC_D13_3V3	CIF_D9_M1	GPIO2_C1_d	3.3V
29	CAN_TX_3V3	UART3_RX_M2/I2C4_SDA_M0	GPIO3_A1_u	3.3V
30	LCDC_D14_3V3	CIF_D10_M1	GPIO2_C2_d	3.3V
31	ADKEY_IN0	Recovery mode set(10K PU)		1.8V
32	LCDC_D15_3V3	CIF_D11_M1	GPIO2_C3_d	3.3V
33	ADCIN1			1.8V
34	GPIO1_D1	UART1_RX_M1/I2C5_SDA_M2	GPIO1_D1_d	1.8V



J2	Signal	Description or functions	GPIO serial	IO Voltage
35	ADCIN2			1.8V
36	LCDC_DEN_3V3	I2C3_SCL_M1/SPI1_CS0n_M2	GPIO2_D4_d	3.3V
37	ADCIN3			1.8V
38	LCDC_VSYNC_3V3	UART3_RTSn_M2/SPI1_MOSI	GPIO2_D6_d	3.3V
39	GND	Ground		0V
40	LCDC_HSYNC_3V3	I2C3_SDA_M1/SPI1_CLK_M2	GPIO2_D5_d	3.3V
41	MIPI_DSI_D0N	MIPI DSI TXD0N		1.8V
42	UART2_RX_3V3	For debug	GPIO3_A3_u	3.3V
43	MIPI_DSI_D0P	MIPI DSI TXD0P		1.8V
44	UART2_TX_3V3	For debug	GPIO3_A2_u	3.3V
45	MIPI_DSI_D1N	MIPI DSI TXD1N		1.8V
46	LCDC_CLK_3V3	UART3_CTSn_M2/SPI1_MISO_M2/PWM8_M1	GPIO2_D7_d	3.3V
47	MIPI_DSI_D1P	MIPI DSI TXD1P		1.8V
48	GND	Ground		0V
49	MIPI_DSI_CLKN	MIPI DSI CLKN		1.8V
50	PCM_RX	I2S2_SDI_M0/SPI1_MISO_M1	GPIO1_C5_d	1.8V
51	MIPI_DSI_CLKP	MIPI DSI CLKP		1.8V
52	PCM_CLK	I2S2_SCLK_M0/SPI1_CLK_M1/UART1_RTSn_M1	GPIO1_C6_d	1.8V
53	MIPI_DSI_D3N	MIPI DSI TXD3N		1.8V
54	PCM_SYNC	I2S2_LRCK_M0/SPI1_CSn0_M1/UART1_CTSn_M1	GPIO1_C7_d	1.8V
55	MIPI_DSI_D3P	MIPI DSI TXD3P		1.8V
56	PCM_TX	I2S2_SDO_M0/SPI1_MOSI_M1	GPIO1_C4_d	1.8V
57	MIPI_DSI_D2N	MIPI DSI TXD2N		1.8V
58	GPIO1_D0	I2S2_MCLK_M0/SPI1_CSn1_M1/UART1_TX_M1/I2C5_SCLK	GPIO1_D0_d	1.8V
59	MIPI_DSI_D2P	MIPI DSI TXD2P		1.8V
60	SDIO_D2		GPIO1_B6_u	1.8V
61	GND	Ground		0V
62	SDIO_D3		GPIO1_B7_u	1.8V
63	MDI3-	Ethernet MDI3 negative out		0V
64	SDIO_CMD		GPIO1_B3_u	1.8V
65	MDI3+	Ethernet MDI3 positive out		0V
66	GND	Ground		0V
67	MDI2-	Ethernet MDI2 negative out		0V
68	SDIO_CLK		GPIO1_B2_d	1.8V
69	MDI2+	Ethernet MDI2 positive out		0V
70	SDIO_D0		GPIO1_B4_u	1.8V
71	MDI1-	Ethernet MDI1 negative out		0V
72	SDIO_D1		GPIO1_B5_u	1.8V



J2	Signal	Description or functions	GPIO serial	IO Voltage
73	MDI1+	Ethernet MDI1 positive out		0V
74	LED2/CFG_LDO1			3.3V
75	MDI0-	Ethernet MDI0 negative out		0V
76	LED1/CFG_LDO0			3.3V
77	MDI0+	Ethernet MDI3 positive out		0V
78	VCC1V2_DVDD	Camera 1.2V Power out(400mA)		1V2
79	VCC2V8_AVDD	Camera 2.8V Power out(400mA)		2V8
80	VCC3V3_SD	SD Card Power output(400mA)		3V3

Note:

Most GPIO voltage is 1.8V, but some pins marked 3.3V.

1.7 Development Kit (EM1126)

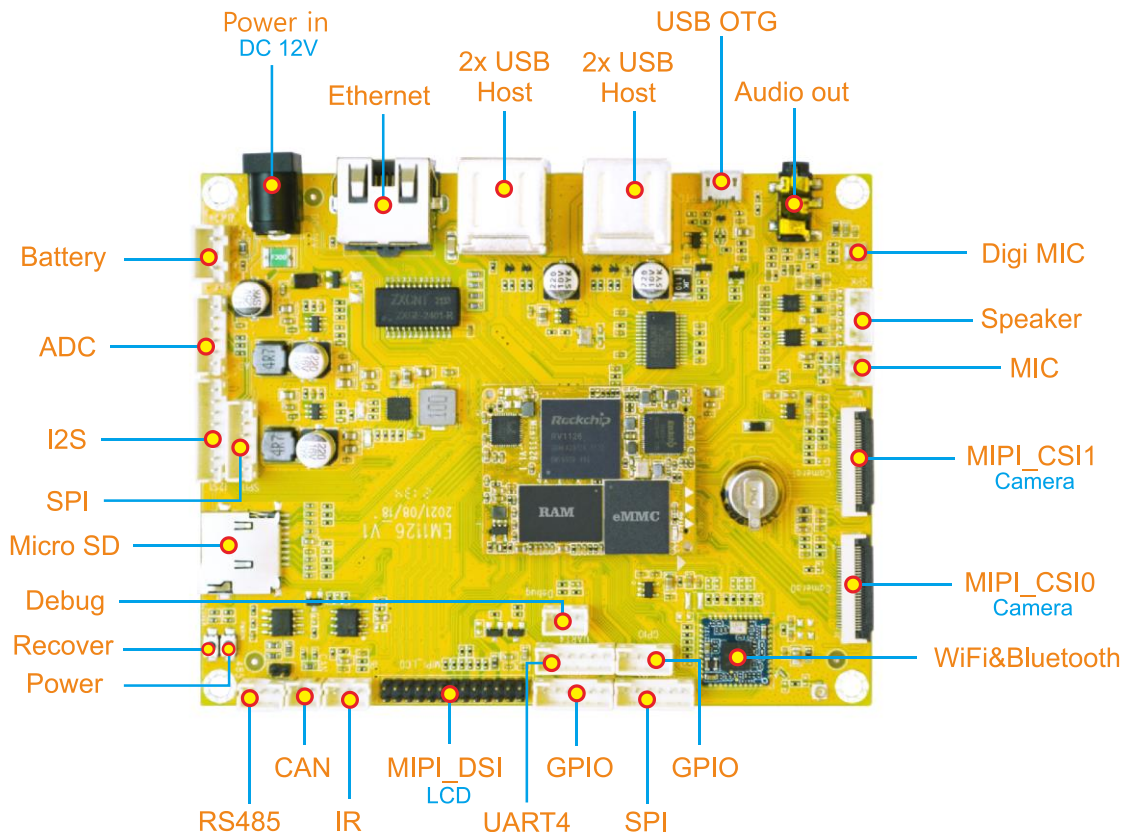



2 Hardware Design Guide

2.1 Peripheral Circuit Reference

2.1.1 Battery Charge Circuit

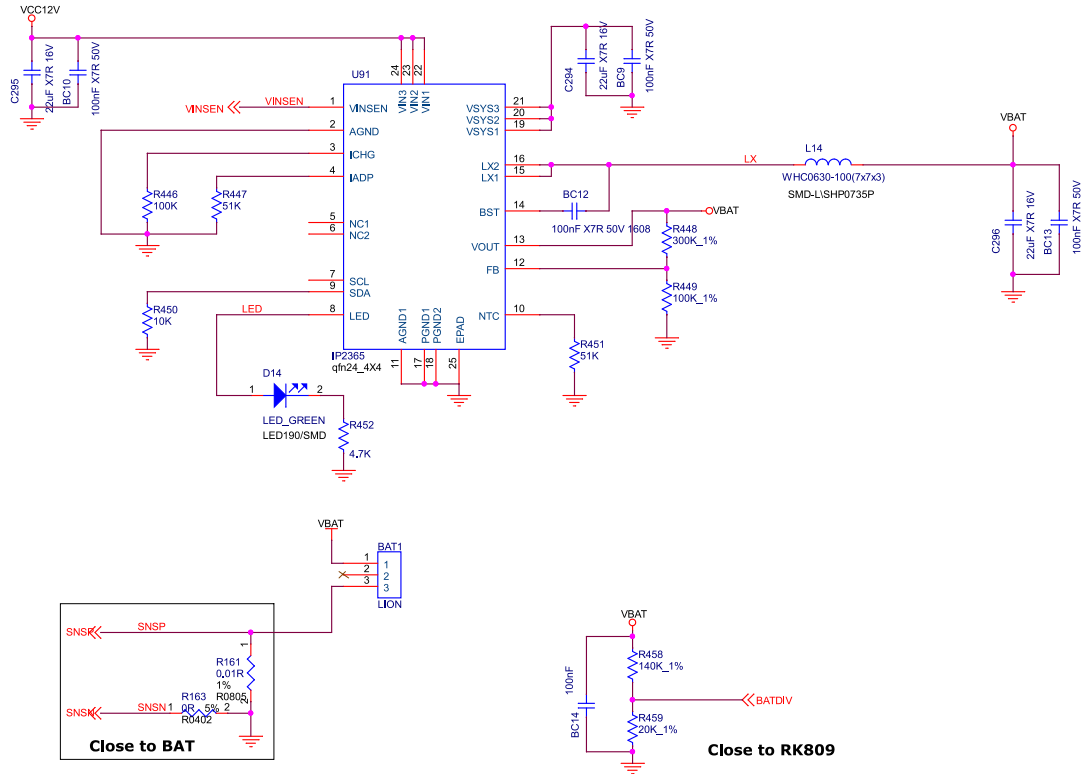

8.4V Lion Battery used

2.1.2 Debug Circuit

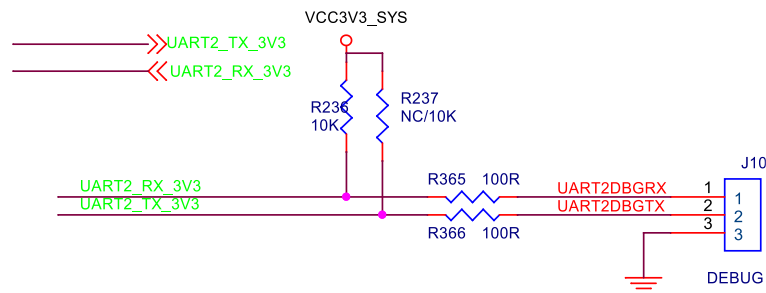



2.2 PCB Footprint

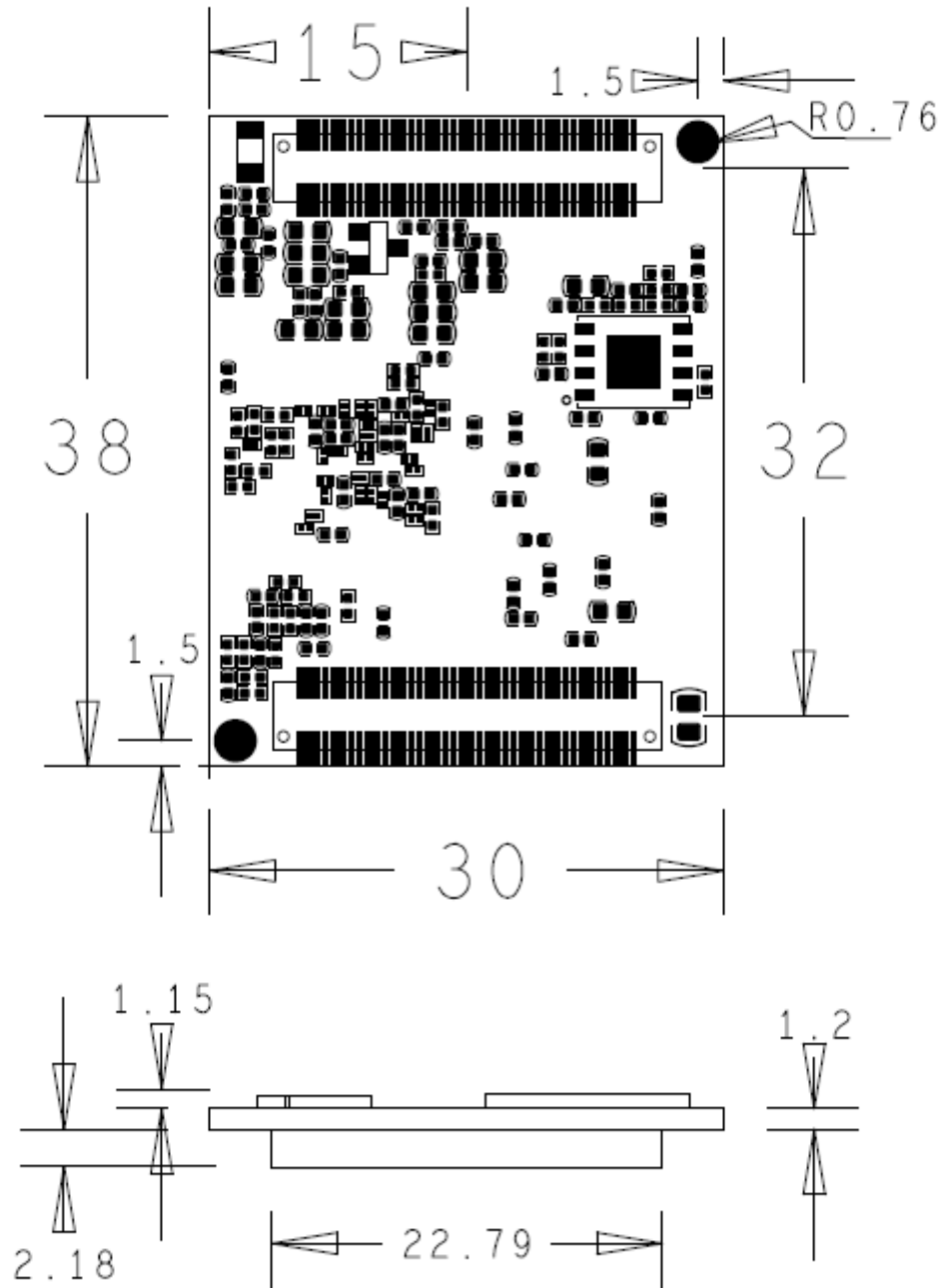



2.3 B2B connector for carrier board

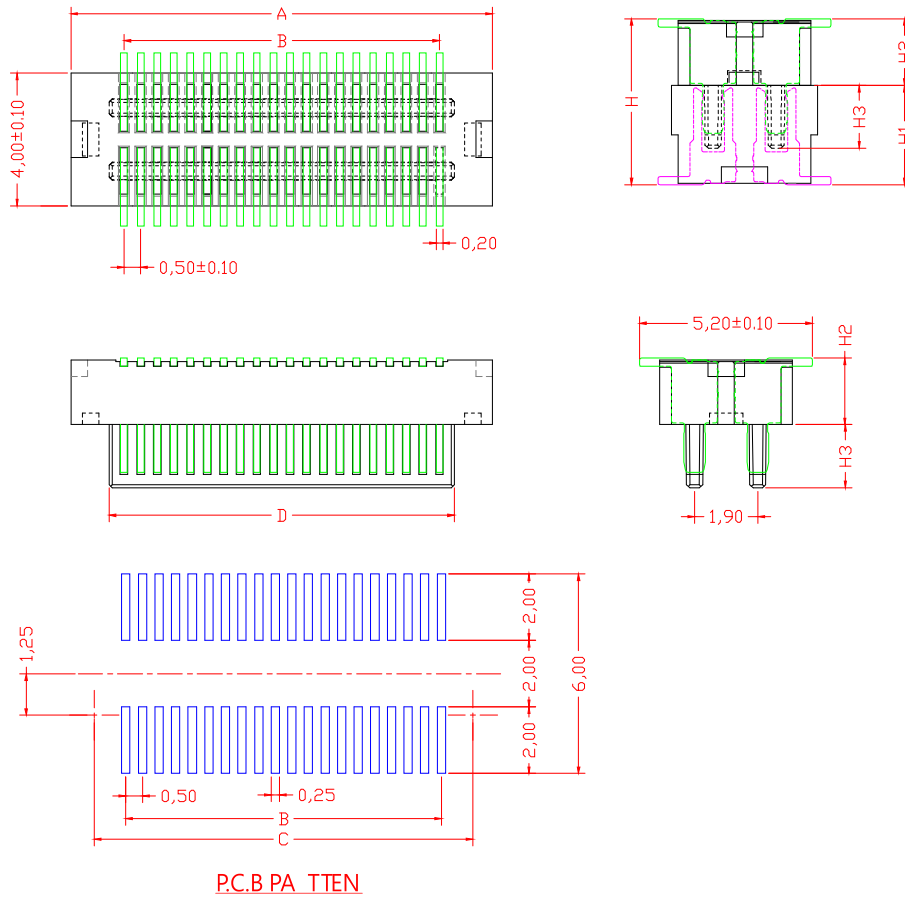

Ordering Information: SGDBM-05-80P-HXX (XX=H2: 08/10/13/20/40 Unit: 0.1mm)

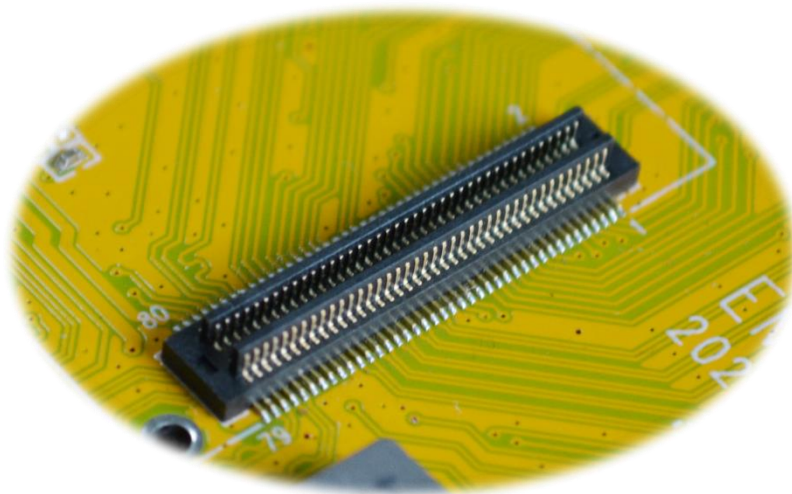



3 Product Electrical Characteristics

3.1 Dissipation and Temperature

Symbol	Parameter	Min	Typ	Max	Unit
VCC5V_SYS	System IO Voltage	3.6	5	5.5	V
I _{sys_in}	VCC5V_SYS input Current		850		mA
VCC_RTC	RTC Voltage	3	3.7	5	V
I _{rtc}	RTC input Current		50	60	uA
VCC1V2_DVDD	Camera Core Voltage output		1.2		V
I _{1v2_dv}	VCC1V2_DVDD output Current		400		mA
VCC2V8_AVDD	Camera Analog Voltage output		2.8		V
I _{2v8_av}	VCC2V8_AVDD output Current		400		mA
T _a	Operating Temperature	-20		70	°C
T _{stg}	Storage Temperature	-40		85	°C