

CM3399 Reference User Manual

V2. 202205

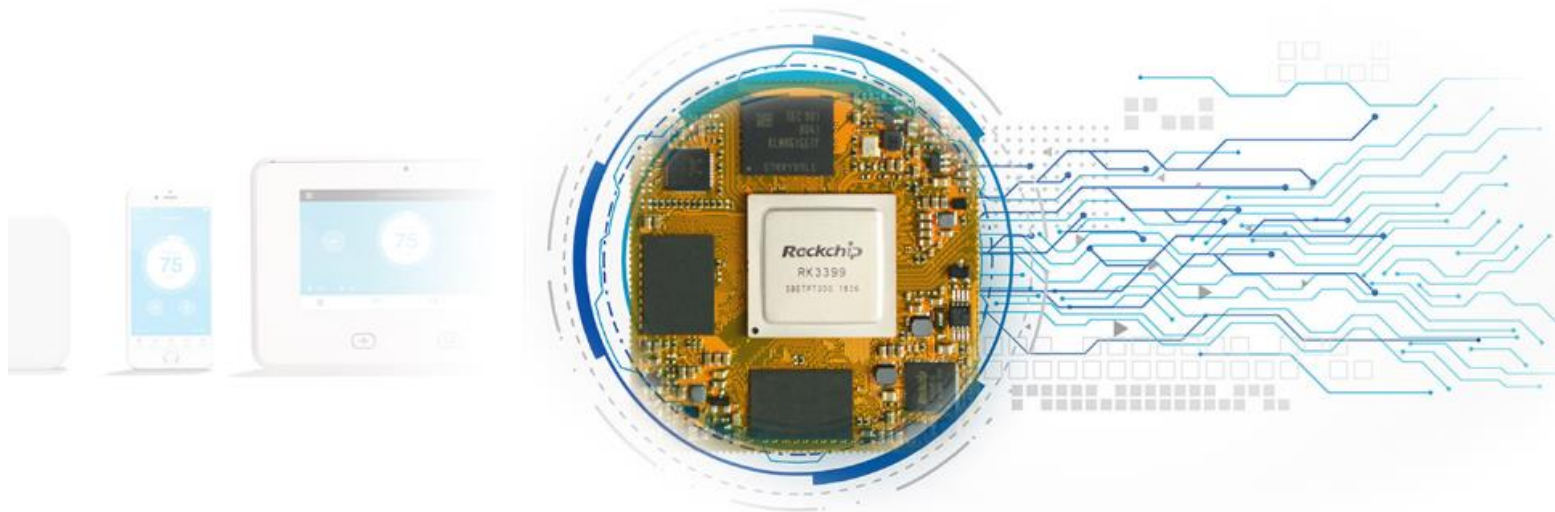

Boardcon Embedded Design

www.armdesigner.com

1. Introduction

1.1. About this Manual

This manual is intended to provide the user with an overview of the board and benefits, complete features specifications, and set up procedures. It contains important safety information as well.

1.2. Feedback and Update to this Manual

To help our customers make the most of our products, we are continually making additional and updated resources available on the Boardcon website (www.boardcon.com, www.armdesigner.com).

These include manuals, application notes, programming examples, and updated software and hardware. Check in periodically to see what's new!

When we are prioritizing work on these updated resources, feedback from customers is the number one influence, if you have questions, comments, or concerns about your product or project, please no hesitate to contact us at support@armdesigner.com.

1.3. Limited Warranty

Boardcon warrants this product to be free of defects in material and workmanship for a period of one year from date of buy. During this warranty period Boardcon will repair or replace the defective unit in accordance with the following process:

A copy of the original invoice must be included when returning the defective unit to Boardcon. This limited warranty does not cover damages resulting from lightning or other power surges, misuse, abuse, abnormal conditions of operation, or attempts to alter or modify the function of the product.

This warranty is limited to the repair or replacement of the defective unit. In no event shall Boardcon be liable or responsible for any loss or damages, including but not limited to any lost profits, incidental or consequential damages, loss of business, or anticipatory profits arising from the use or inability to use this product.

Repairs make after the expiration of the warranty period are subject to a repair charge and the cost of return shipping. Please contact Boardcon to arrange for any repair service and to obtain repair charge information.



Content

1 CM3399 Introduction.....	3
1.1 Summary	3
1.2 RK3399 Features.....	3
1.3 RK3399 Block Diagram.....	5
1.3.1 RK3399 Block Diagram.....	5
1.3.2 Development board (Idea3399) Block Diagram	6
1.4 CM3399 specifications	6
1.5 CM3399 PCB Dimension	7
1.6 CM3399 Pin Definition	8
1.5 The Baseboard (Idea3399) for Application.....	15
2 Hardware Design Guide.....	16
2.1 Peripheral Circuit Reference	16
2.1.1 External Power	16
2.1.2 Debug Circuit.....	16
2.1.3 Software Over Temperature Protect Circuit	16
2.1.4 Type-C Interface Circuit	17
2.2 Power Topology Reference	18
2.2.1 AC Input Only.....	18
2.2.2 Battery Input	18
2.3 GPIO Level-shift Reference	19
2.3.1 UART or I2C Circuit	19
2.3.2 GPIO or SPI Circuit.....	19
3 Electric Property.....	19
3.1 Dissipation and Temperature	19
3.2 Reliability of Test.....	20
3.3 Certifications	21

1 CM3399 Introduction

1.1 Summary

The CM3399 system-on-module is equipped with Rockchip RK3399 dual-core Cortex-A72 + Quad-core Cortex-A53 processor, Mali-T864 GPU, 4GB LPDDR4 and 8GB eMMC.

The CM3399 module is designed specifically for the AI devices such as IoT devices, intelligent interactive devices, personal computers and robots. The high performance and low power solution can help customers to introduce new technologies more quickly and enhance the overall solution efficiency.

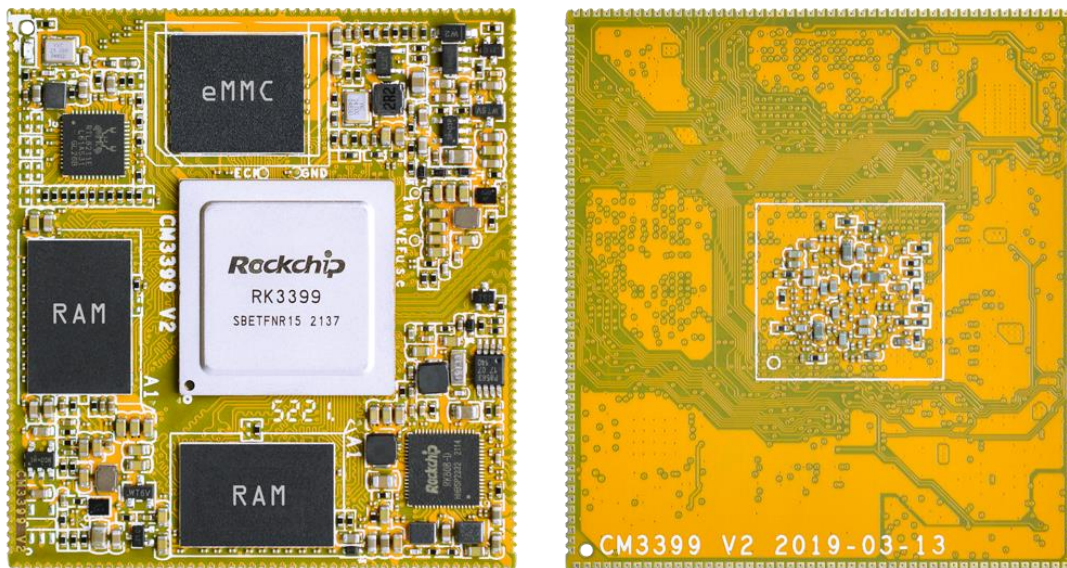

1.2 RK3399 Features

- **Microprocessor**
 - Dual-core ARM Cortex-A72 up to 1.8G.
 - Quad-core ARM Cortex-A53 up to 1.4G.
 - 1MB unified L2 Cache for Big cluster, 512KB unified L2 Cache for Little cluster.
- **Memory Organization**
 - On board memory
 - LPDDR4 up to 4GB.
 - EMMC5.1 up to 128GB.
 - External memory.
 - SPI NOR
- **Cortex-M0**
 - Two Cortex-M0 cooperate with Cortex-A72/Cortex-A53.
 - Integrated sleep modes for low power consumption.
 - Serial Wire Debug reduces the number of pins required for debugging.
- **PWM**



- Four on-chip PWMs with interrupt-based operation.
- Support capture mode and continuous mode or one-shot mode.
- **WatchDog**
 - Three WatchDogs in SoC with 32 bits counter width.
- **Interrupt Controller**
 - Support 8 PPI interrupt source and 148 SPI interrupt sources input.
 - Support 16 software-triggered interrupts.
- **3D Graphics Engine**
 - Arm Mali-T860MP4 GPU up to 4K supply.
 - High performance OpenGL ES1.1/2.0/3.0, OpenCL1.2, DirectX11.1 etc.
 - Provide MMU and L2 Cache with 256KB size
- **Power unit**
 - RK808 on board.
 - Compatible with multiple mode power supply.
Such as 3.7V/7.4V battery, single 3.3V DC or 3.3V/5V DC.
 - Very low RTC consume current, less 7uA at 3V button Cell.
- **Temperature**
 - Less 46° run video play (exposed board at 20°).
 - Less 60° run Antutu test (exposed board at 20°)

1.3 RK3399 Block Diagram

1.3.1 RK3399 Block Diagram

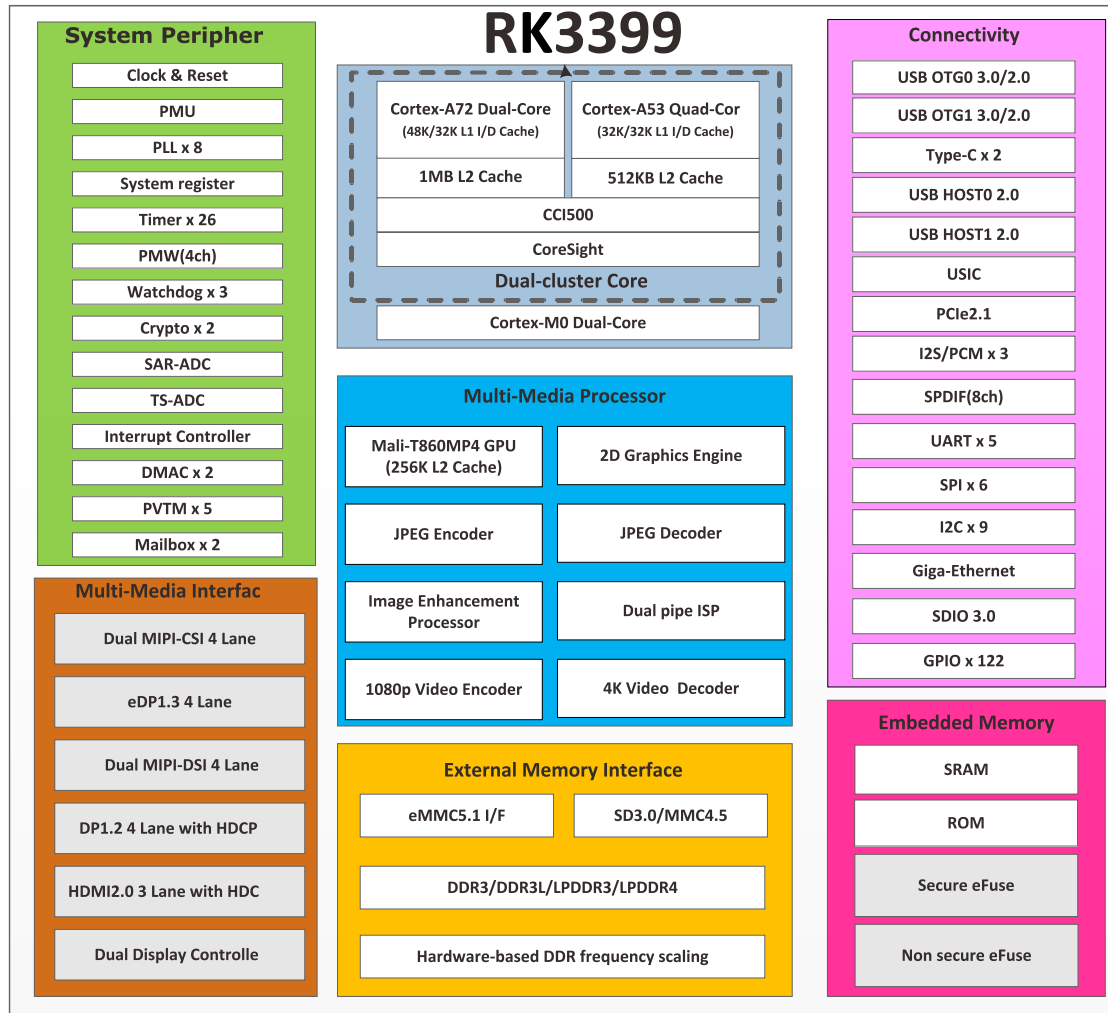

1.3.2 Development board (Idea3399) Block Diagram

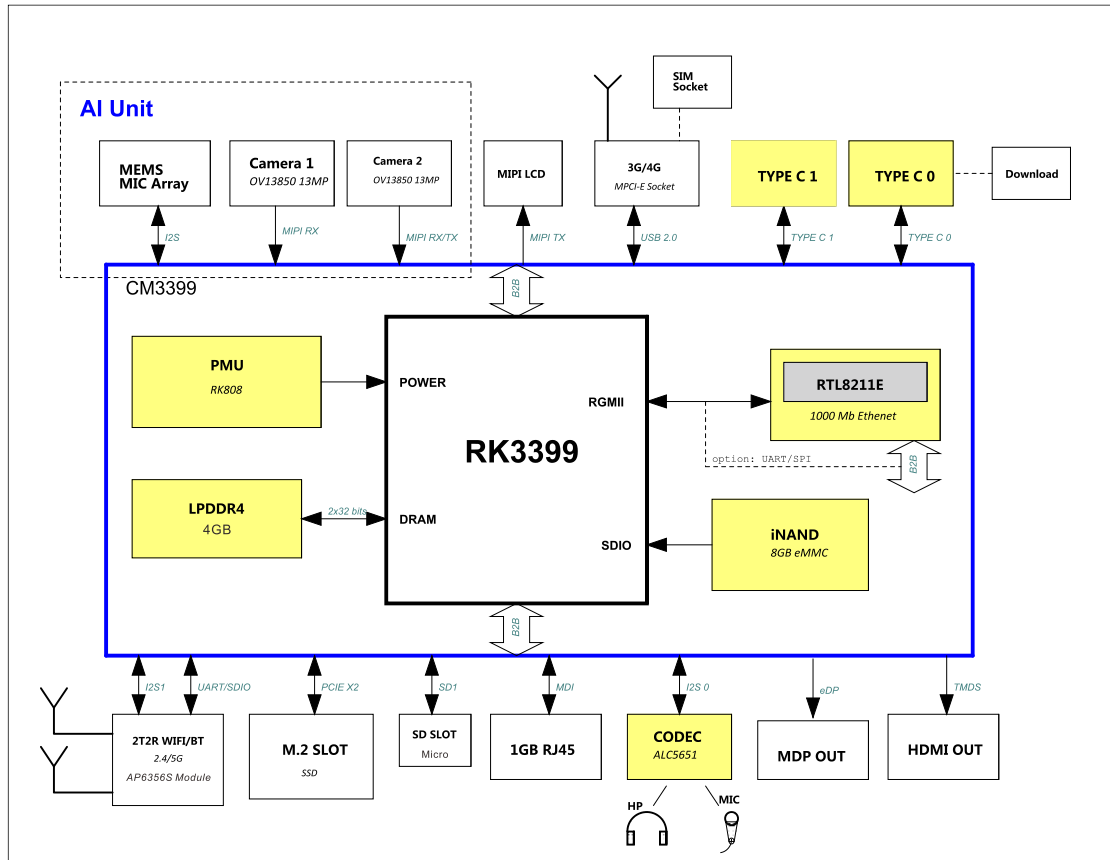

1.4 CM3399 specifications

Feature	Specifications
CPU	Dual-core ARM Cortex-A72 Quad-core ARM Cortex-A53
DDR	up to 4GB
eMMC FLASH	On board 8GB (up to 128GB)
Power	DC 3.3V-5V
eDP	1-CH
PCI-E X2	1-CH
I2S	2-CH
MIPI0_TX	1-CH
MIPI_RX	1-CH
MIPI_TX_RX	1-CH
HDMI out	1-CH
Camera	1-CH(DVP)
USB	2-CH (USB HOST2.0), 2-CH(OTG), 2-CH(USB3.0)



Ethernet or UART&SPI	100M/1G(RTL8211E) If the Ethernet is not needed, it can be designed to 2x UART and 1x SPI.
SDMMC	1-CH
SDIO	1-CH
I2C	6-CH
SPI	2-CH
USART	2-CH , 1-CH(DEBUG)
PWM	3-CH
ADC IN	2-CH
Board Dimension	55 x 50mm

1.5 CM3399 PCB Dimension

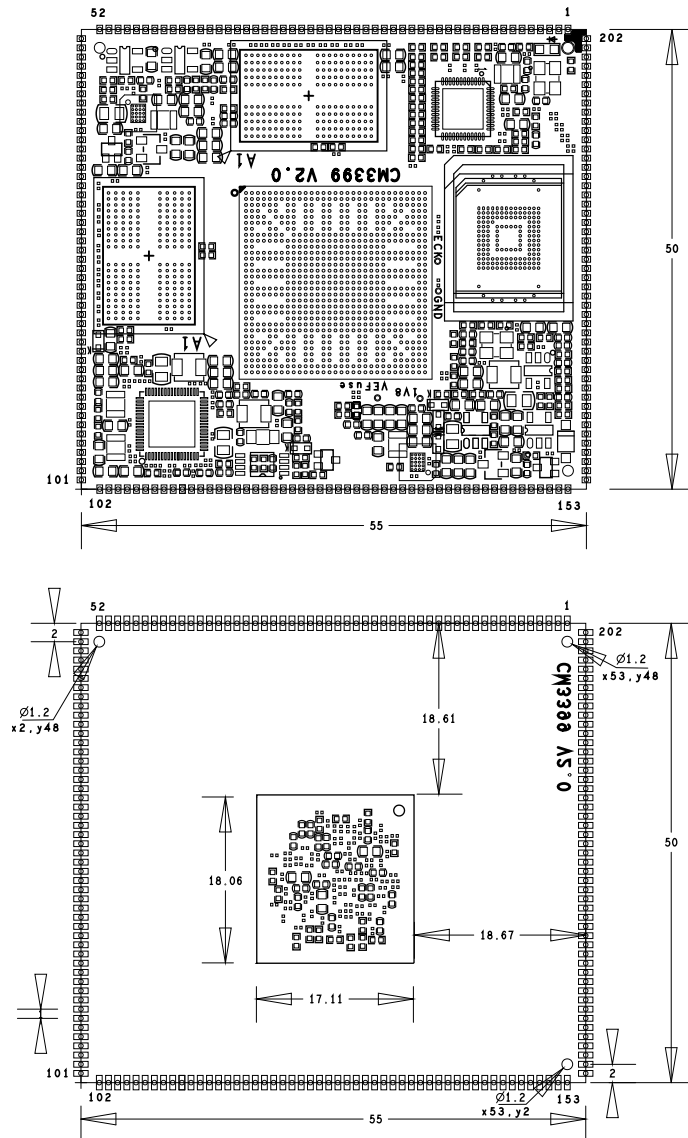



1.6 CM3399 Pin Definition

Pin	Signal	Description	Alternate functions	IO Voltage
1	SDMMC_CMD	SDMMC card command output and response input	GPIO4_B5	3.0V
2	SDMMC0_DET_L	SDMMC card detect signal (10K Pull H)	GPIO0_A7	1.8V
3	SDMMC_D0	SDMMC card data input and output	GPIO4_B0	3.0V
4	SDMMC_D1	SDMMC card data input and output	GPIO4_B1	3.0V
5	SDMMC_D2	SDMMC card data input and output	GPIO4_B2	3.0V
6	SDMMC_D3	SDMMC card data input and output	GPIO4_B3	3.0V
7	ADKEY_IN	10bit ADC input signal (10K Pull H)	ADIN1 & Recover	1.8V
8	ADC_IN2	10bit ADC input signal	ADIN2	1.8V
9	LED1_AD1	Ethernet Speed LED(H)		3.3V
10	LED0_AD0_SPDIF-TX	ETH Link LED(L) or Spdif TX		3.3V
11	GND	GND		0V
12	MDI0+_UART1-TX	ETH MD0+ or TXD1(HW setting)		3.3V
13	MDI0-_UART1-RX	ETH MD0- or RXD1(HW setting)		3.3V
14	MDI1+_SPI0-TXD	ETH MD1+ or SPI0TXD(HW setting)		3.3V
15	MDI1-_SPI0-CSn0	ETH MD1- or SPI0CS0(HW setting)		3.3V
16	MDI2+_SPI0-CLK	ETH MD2+ or SPI0CLK(HW setting)		3.3V
17	MDI2-_SPI0-RXD	ETH MD2- or SPI0RXD(HW setting)		3.3V
18	MDI3+_UART3-TX	ETH MD3+ or TXD3(HW setting)		3.3V
19	MDI3-_UART3-RX	ETH MD3- or RXD3(HW setting)		3.3V
20	BT_HOST_WAKE_L	Bluetooth device to wake-up HOST	GPIO0_A4	1.8V
21	GPIO1_A2	GPIO		1.8V
22	WIFI_REG_ON_H	WIFI Regulators power EN	GPIO0_B2	1.8V
23	WIFI_HOST_WAKE_L	WIFI to wake-up HOST	GPIO0_A3	1.8V
24	CIF_CLKOUT	Camera main clock output	GPIO2_B3	1.8V
25	OTP_OUT_H	Over temperature	GPIO1_A6	1.8V
26	I2C4_SCL	I2C serial clock line (Need pull H)	GPIO1_B4	1.8V
27	ALRT_H	Battery Gauge IC interrupt	GPIO1_C2	1.8V
28	I2C4_SDA	I2C data line (Need pull H)	/GPIO1_B3	1.8V
29	SPI1_CS _{n0}	SPI first chip select signal	SPI1CS /GPIO1_B2	1.8V
30	SPI1_TXD	SPI serial data output	SPI1TX /TXD4 /GPIO1_B0	1.8V
31	GPIO1_A1	GPIO		1.8V
32	BT_REG_ON_H	Bluetooth power on		1.8V
33	SPI1_CLK	SPI serial clock	SPI1CLK	1.8V



Pin	Signal	Description	Alternate functions	IO Voltage
			/GPIO1_B1	
34	SPI1_RXD	SPI serial data input	SPI1RX /RXD4 /GPIO1_A7	1.8V
35	CIF_PDN0	CIF power ON/OFF	SPI2CS /GPIO2_B4	1.8V
36	I2C2_SCL	I2C serial clock line (Need pull H)	GPIO2_A1	1.8V
37	I2C2_SDA	I2C data line (Need pull H)	GPIO2_A0	1.8V
38	I2C6_SCL	I2C serial clock line (Need pull H)	SPI2TX /GPIO2_B2	1.8V
39	I2C6_SDA	I2C data line (Need pull H)	SPI2RX /GPIO2_B1	1.8V
40	GPIO1_A3	GPIO		1.8V
41	GPIO1_A0	GPIO		1.8V
42	PWM3_IRIN	Pulse Width Modulation output, special design for IR receiver	PWM3 /IR_IN /GPIO0_A6	1.8V
43	PCIE_WAKE#		GPIO1_B5	1.8V
44	I2C1_SCL	I2C1 Bus Clock (Need pull H)	GPIO4_A2	1.8V
45	I2C1_SDA	I2C1 Bus Data (Need pull H)	GPIO4_A1	1.8V
46	I2S1_LRCK	I2S1 LRCK input	GPIO4_A4 & GPIO4_A5	1.8V
47	I2S1_SDO0	I2S1 Data0 output	GPIO4_A7	1.8V
48	I2S_CLK	I2S clock	GPIO4_A0	1.8V
49	I2S1_SDI0	I2S serial data input	GPIO4_A6	1.8V
50	I2S1_SCLK	I2S serial clock	GPIO4_A3	1.8V
51	I2S0_LRCK	I2S left & right channel signal for receiving/ transmitting serial data	GPIO3_D1 & GPIO3_D2	1.8V
52	I2S0_SCLK	I2S serial clock	GPIO3_D0	1.8V
53	I2S0_SDO0	I2S serial data output	GPIO3_D7	1.8V
54	I2S0_SDO1	I2S serial data output	GPIO3_D6	1.8V
55	I2S0_SDO2	I2S serial data output	GPIO3_D5	1.8V
56	I2S0_SDO3	I2S serial data output	GPIO3_D4	1.8V
57	I2S0_SDI0	I2S serial data input	GPIO3_D3	1.8V
58	LCD_BL_PWM	Backlight PWM output	PWM0 /GPIO4_C2	3.0V
59	PCIE_PRSENT		GPIO4_D6	3.0V
60	UART2DBG_RX	Debug UART RXD	RXD2 /GPIO4_C3	3.0V
61	UART2DBG_TX	Debug UART TXD	TXD2 /GPIO4_C4	3.0V
62	I2C_SCL_HDMI	I2C clock line for HDMI	I2C3_SCL /GPIO4_C1	3.0V
63	I2C_SDA_HDMI	I2C data line for HDMI	I2C3_SDA /GPIO4_C0	3.0V



Pin	Signal	Description	Alternate functions	IO Voltage
64	3V_GPIO4_D4	GPIO		3.0V
65	PCIE_PERST#		GPIO4_D5	3.0V
66	3V_GPIO4_C5	GPIO	GPIO4_C5 /SPDIF_TX	3.0V
67	3V_GPIO4_D2	GPIO		3.0V
68	TOUCH_RST_L	Touch screen reset	GPIO4_C6/PWM1	3.0V
69	3V_GPIO4_D0	GPIO	PCIE_CLKREQnB	3.0V
70	HDMI_CEC	HDMI CEC signal	GPIO4_C7	3.0V
71	3V_GPIO4_D3	GPIO		3.0V
72	3V_GPIO4_D1	GPIO		3.0V
73	GND	GND		0V
74	SDIO0_CLK	SDIO card clock	GPIO2_D1	1.8V
75	SDIO0_CMD	SDIO card command output and response input	GPIO2_D0	1.8V
76	SDIO0_D0	SDIO card data input and output	/SPI5RX /GPIO2_C4	1.8V
77	SDIO0_D1	SDIO card data input and output	/SPI5TX /GPIO2_C5	1.8V
78	SDIO0_D2	SDIO card data input and output	/SPI5CLK /GPIO2_C6	1.8V
79	SDIO0_D3	SDIO card data input and output	/SPI5CS /GPIO2_C7	1.8V
80	BT_WAKE_L	BT wake CPU in	SDIO0_DET /GPIO2_D2	1.8V
81	UART0_RXD	UART serial data input	GPIO2_C0	1.8V
82	UART0_RTS	UART request to send	GPIO2_C3	1.8V
83	UART0_CTS	UART clear to send	GPIO2_C2	1.8V
84	UART0_TXD	UART serial data output	GPIO2_C1	1.8V
85	HDMI_HPD	HDMI hot plug detect signal (Single function)		3.3V
86	TYPEC0_ID	USB 2.0 OTG ID detection (Single function)		3.3V
87	POWER_KEY	Key input (Single function)		5V
88	Reset_KEY	Key input (Single function)		5V
89	PMIC_EXT_EN	EXT-DCDC enable (Single function)		5V
90	GND	GND		0V
91	MIPI_TX/RX_D0P	MIPI CSI positive differential data line transceiver output		1.8V
92	MIPI_TX/RX_D0N	MIPI CSI negative differential data line transceiver output		1.8V
93	MIPI_TX/RX_D1P	MIPI CSI positive differential data		1.8V



Pin	Signal	Description	Alternate functions	IO Voltage
		line transceiver output		
94	MIPI_TX/RX_D1N	MIPI CSI negative differential data line transceiver output		1.8V
95	MIPI_TX/RX_CLKP	MIPI CSI positive differential clock line transceiver output		1.8V
96	MIPI_TX/RX_CLKN	MIPI CSI negative differential clock line transceiver output		1.8V
97	MIPI_TX/RX_D2P	MIPI CSI positive differential data line transceiver output		1.8V
98	MIPI_TX/RX_D2N	MIPI CSI negative differential data line transceiver output		1.8V
99	MIPI_TX/RX_D3P	MIPI CSI positive differential data line transceiver output		1.8V
100	MIPI_TX/RX_D3N	MIPI CSI negative differential data line transceiver output		1.8V
101	GND	GND		0V
102	VCC_SYS	Main power input		3.3V-5V
103	VCC_SYS	Main power input		3.3V-5V
104	VCC3V3_SYS	VCC_IO input (Pin89 control)		3.3V
105	VCC3V3_SYS	VCC_IO input (Pin89 control)		3.3V
106	GND	GND		0V
107	RTC_CLKO_WIFI	RTC CLK output for WiFi32.768KHz		1.8V
108	VCCA1V8_CODEC	Codec Power output (200mA)		1.8V
109	VBuck	PMU start power (Connect VCC_SYS or before than it)		3.3V-5V
110	VCC_RTC	Button Cell input (If not need, NC)		1.8V-3.3V
111	VCC3V3_S0	LCD Power output (350mA)		3.3V
112	VCCA3V0_CODEC	Codec Power output (300mA)		3.0V
113	VCC1V8_DVP	Camera IO Power out (80mA)		1.8V
114	VCC3V0_TOUCH	Touch panel Power (150mA)		3.0V
115	MIPI_TX_D3N	MIPI DSI negative differential data line transceiver output	DSI	1.8V
116	MIPI_TX_D3P	MIPI DSI positive differential data line transceiver output	DSI	1.8V
117	MIPI_TX_D2N	MIPI DSI negative differential data line transceiver output	DSI	1.8V
118	MIPI_TX_D2P	MIPI DSI positive differential data line transceiver output	DSI	1.8V
119	MIPI_TX_CLKN	MIPI DSI negative differential clock line transceiver output	DSI	1.8V
120	MIPI_TX_CLKP	MIPI DSI positive differential clock	DSI	1.8V



Pin	Signal	Description	Alternate functions	IO Voltage
		line transceiver output		
121	MIPI_TX_D1N	MIPI DSI negative differential data line transceiver output	DSI	1.8V
122	MIPI_TX_D1P	MIPI DSI positive differential data line transceiver output	DSI	1.8V
123	MIPI_TX_D0N	MIPI DSI negative differential data line transceiver output	DSI	1.8V
124	MIPI_TX_D0P	MIPI DSI positive differential data line transceiver output	DSI	1.8V
125	GND	GND		0V
126	MIPI_RX_D3P	MIPI CSI positive differential data line transceiver output	CSI	1.8V
127	MIPI_RX_D3N	MIPI CSI negative differential data line transceiver output	CSI	1.8V
128	MIPI_RX_D2P	MIPI CSI positive differential data line transceiver output	CSI	1.8V
129	MIPI_RX_D2N	MIPI CSI negative differential data line transceiver output	CSI	1.8V
130	MIPI_RX_CLKP	MIPI CSI positive differential clock line transceiver output	CSI	1.8V
131	MIPI_RX_CLKN	MIPI CSI negative differential clock line transceiver output	CSI	1.8V
132	MIPI_RX_D1P	MIPI CSI positive differential data line transceiver output	CSI	1.8V
133	MIPI_RX_D1N	MIPI CSI negative differential data line transceiver output	CSI	1.8V
134	MIPI_RX_D0P	MIPI CSI positive differential data line transceiver output	CSI	1.8V
135	MIPI_RX_D0N	MIPI CSI negative differential data line transceiver output	CSI	1.8V
136	GND	GND		0V
137	TX_C-	HDMI TXC-		1.8V
138	TX_C+	HDMI TXC+		1.8V
139	TX_0-	HDMI TXD0-		1.8V
140	TX_0+	HDMI TXD0+		1.8V
141	TX_1-	HDMI TXD1-		1.8V
142	TX_1+	HDMI TXD1+		1.8V
143	TX_2-	HDMI TXD2-		1.8V
144	TX_2+	HDMI TXD2+		1.8V
145	GND	GND		0V
146	TYPEC0_AUXP	AUX differential Tx serial data		1.8V



Pin	Signal	Description	Alternate functions	IO Voltage
147	TYPEC0_AUXM	AUX differential Rx serial data		1.8V
148	TYPEC0_RX1P	Receiver serial data +		1.8V
149	TYPEC0_RX1N	Receiver serial data -		1.8V
150	TYPEC0_TX1N	Transmitter serial data -		1.8V
151	TYPEC0_TX1P	Transmitter serial data +		1.8V
152	TYPEC0_TX2P	Transmitter serial data +		1.8V
153	TYPEC0_TX2N	Transmitter serial data -		1.8V
154	GND	GND		0V
155	TYPEC0_DP	USB 2.0 data DP		1.8V
156	TYPEC0_DM	USB 2.0 data DN		1.8V
157	TYPEC0_RX2N	Receiver serial data -		1.8V
158	TYPEC0_RX2P	Receiver serial data+		1.8V
159	VBUS_TYPEC0	VBUS BUMP into the PHY for VBUS monitor		5V-12V
160	TYPEC1_DM	USB 2.0 data DN		1.8V
161	TYPEC1_DP	USB 2.0 data DP		1.8V
162	TYPEC1_U2VBUSDET	VBUS BUMP into the PHY for VBUS monitor		3.3V
163	HOST1_DP	USB 2.0 data DP		1.8V
164	HOST1_DM	USB 2.0 data DN		1.8V
165	GND	GND		0V
166	TYPEC1_TX1P	Transmitter serial data +		1.8V
167	TYPEC1_TX1N	Transmitter serial data -		1.8V
168	TYPEC1_RX2N	Receiver serial data -		1.8V
169	TYPEC1_RX2P	Receiver serial data+		1.8V
170	TYPEC1_RX1P	Receiver serial data+		1.8V
171	TYPEC1_RX1N	Receiver serial data -		1.8V
172	TYPEC1_TX2P	Transmitter serial data +		1.8V
173	TYPEC1_TX2N	Transmitter serial data -		1.8V
174	TYPEC1_AUXM	AUX differential Tx serial data		1.8V
175	TYPEC1_AUXP	AUX differential Rx serial data		1.8V
176	GND	GND		0V
177	PCIE_RX1_P	PCIe differential data input signal +		1.8V
178	PCIE_RX1_N	PCIe differential data input signal -		1.8V
179	PCIE_TX1P	PCIe differential data output signal +		1.8V
180	PCIE_TX1N	PCIe differential data output signal -		1.8V
181	PCIE_RX0_P	PCIe differential data input signal +		1.8V
182	PCIE_RX0_N	PCIe differential data input signal -		1.8V
183	PCIE_TX0P	PCIe differential data output signal +		1.8V



Pin	Signal	Description	Alternate functions	IO Voltage
184	PCIE_TX0N	PCIe differential data output signal -		1.8V
185	PCIE_REF_CLKN	Reference clock -		1.8V
186	PCIE_REF_CLKP	Reference clock +		1.8V
187	GND	GND		0V
188	HOST0_DP	USB host 0 data +		1.8V
189	HOST0_DM	USB host 0 data -		1.8V
190	GND	GND		0V
191	eDP_TX3P	eDP data lane output +	Capacitor on core board	1.8V
192	eDP_TX3N	eDP data lane output -	Capacitor on core board	1.8V
193	eDP_TX2P	eDP data lane output +	Capacitor on core board	1.8V
194	eDP_TX2N	eDP data lane output -	Capacitor on core board	1.8V
195	eDP_TX1P	eDP data lane output +	Capacitor on core board	1.8V
196	eDP_TX1N	eDP data lane output -	Capacitor on core board	1.8V
197	eDP_TX0P	eDP data lane output +	Capacitor on core board	1.8V
198	eDP_TX0N	eDP data lane output -	Capacitor on core board	1.8V
199	eDP_AXUP	eDP CH-AUX differential output +		1.8V
200	eDP_AXUN	eDP CH-AUX differential output -		1.8V
201	GND	GND		0V
202	SDMMC_CLK	SDMMC card clock	GPIO4_B4	3.0V

1.5 The Baseboard (Idea3399) for Application

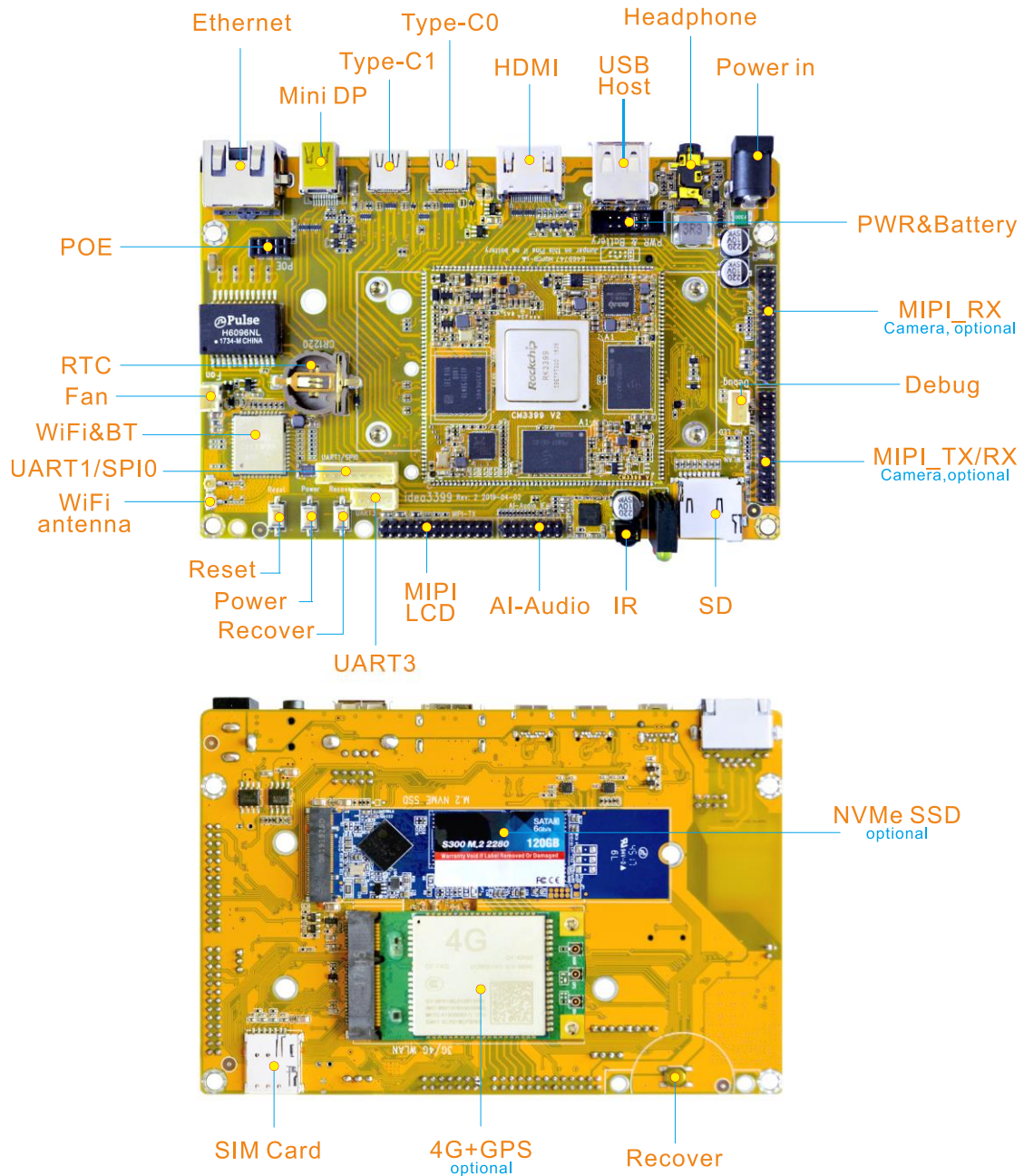



2 Hardware Design Guide

2.1 Peripheral Circuit Reference

2.1.1 External Power

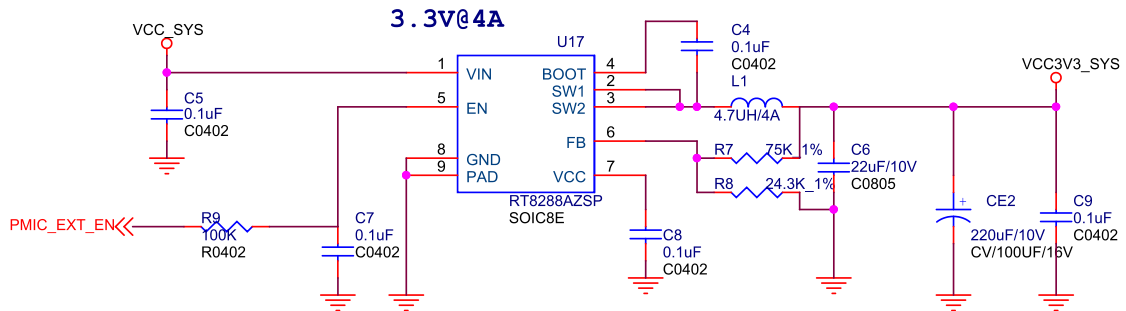

2.1.2 Debug Circuit

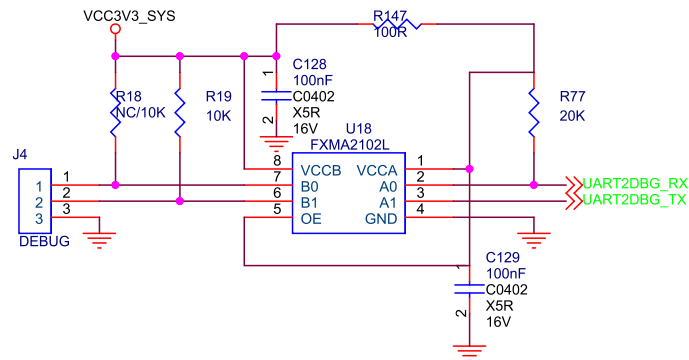

2.1.3 Software Over Temperature Protect Circuit

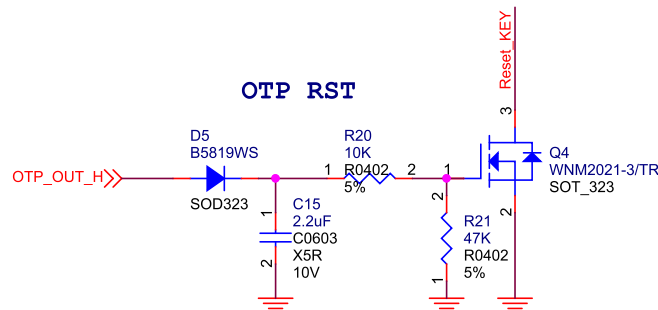



2.1.4 Type-C Interface Circuit

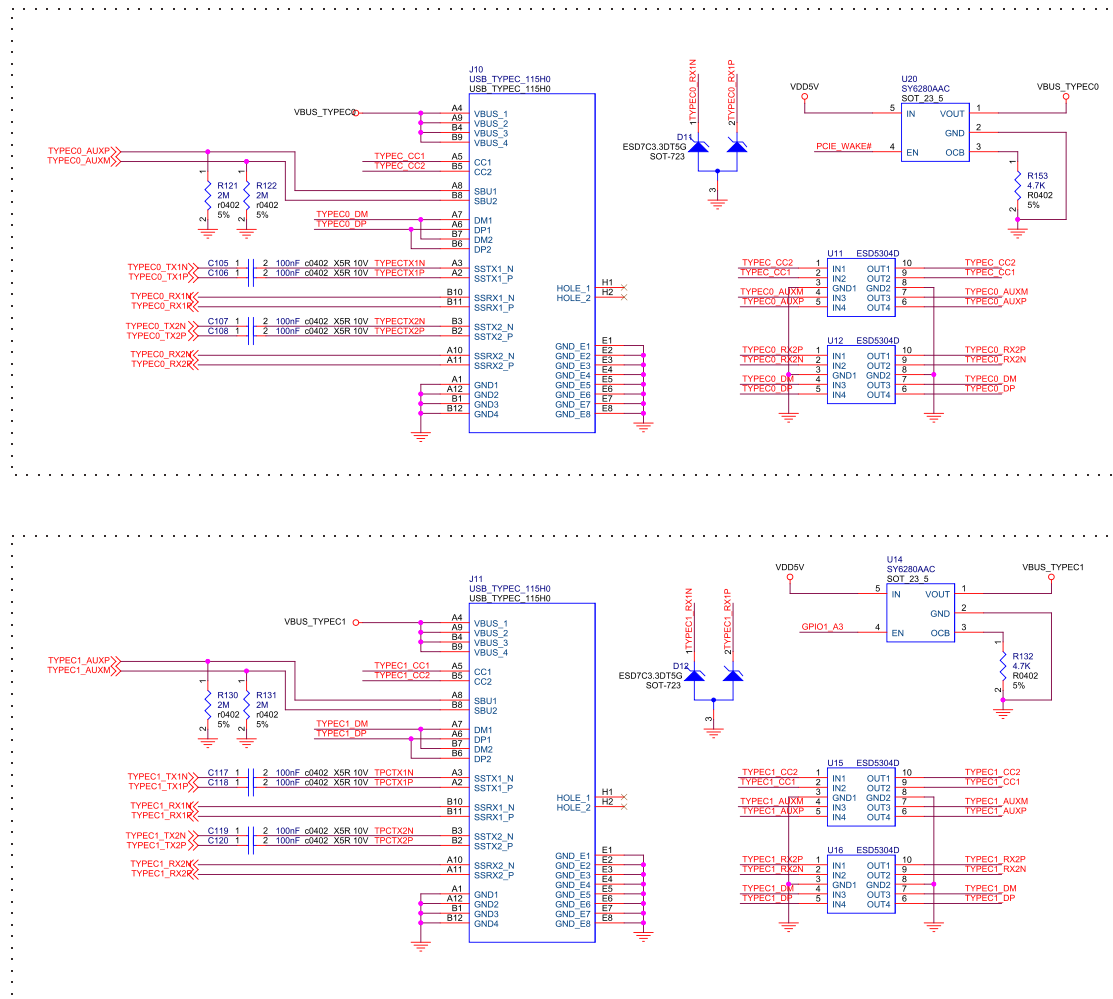

2.2 Power Topology Reference

2.2.1 AC Input Only

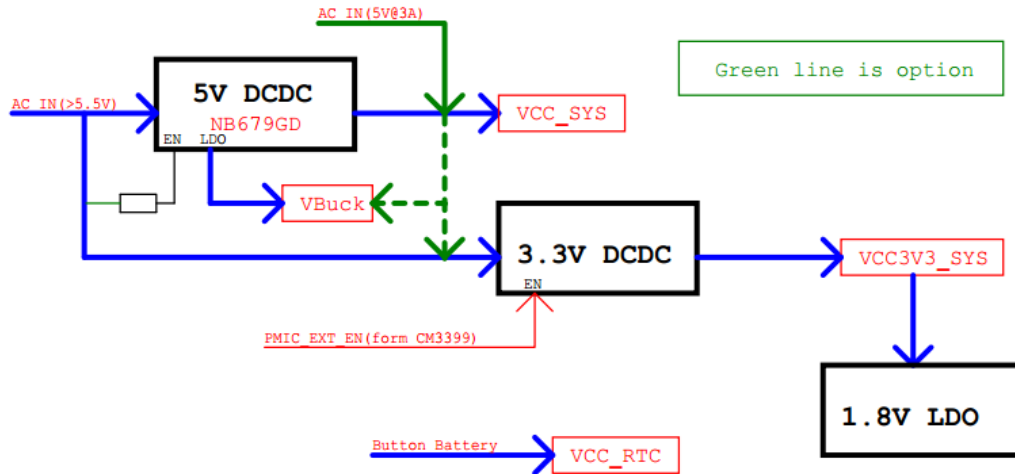

2.2.2 Battery Input

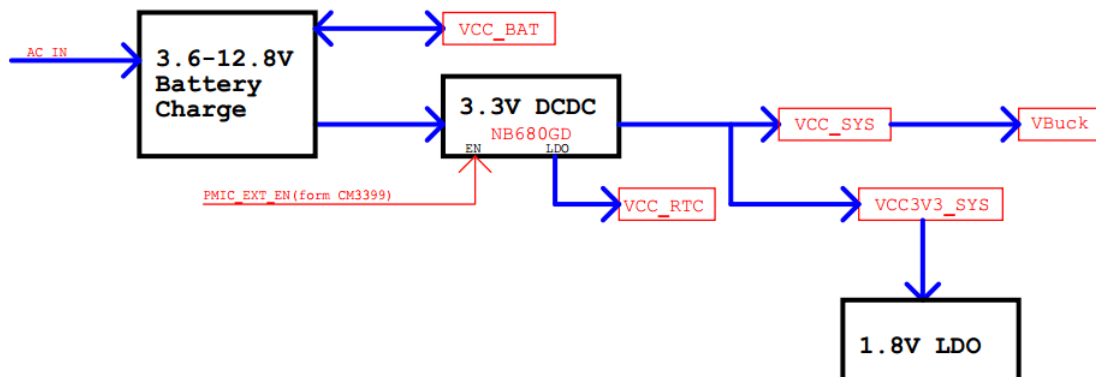

If used 1-4 Cell battery, the solution **BQ25700A+ CW2015CSAD+ NB680GD** is recommended.



2.3 GPIO Level-shift Reference

2.3.1 UART or I2C Circuit

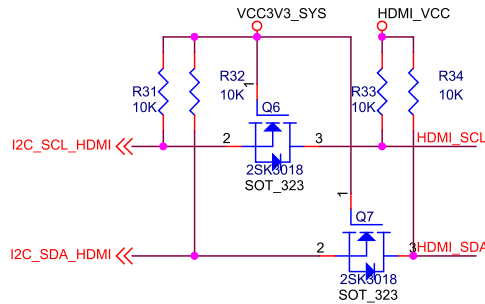

I2C Level Shift

2.3.2 GPIO or SPI Circuit

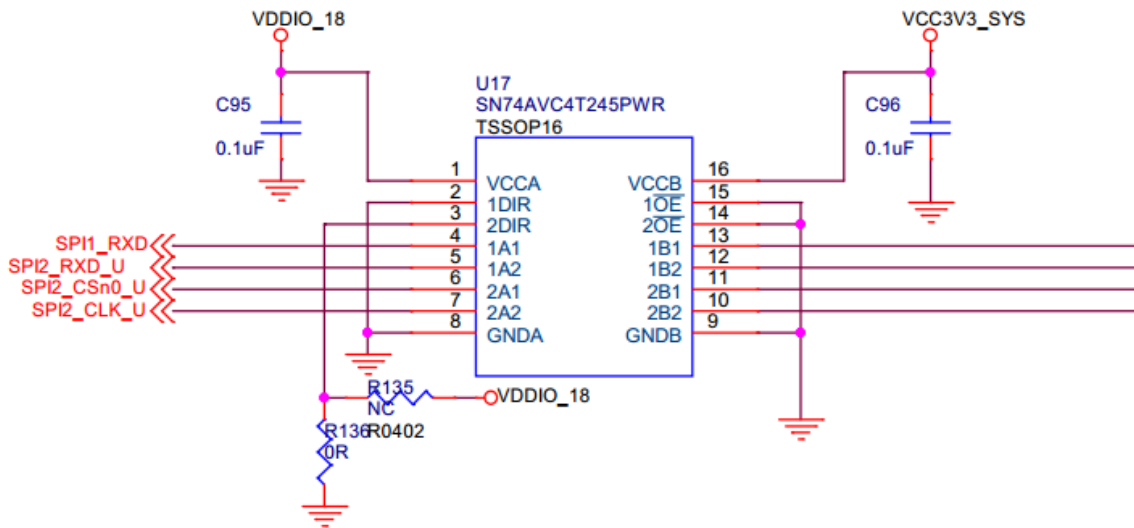

3 Electric Property

3.1 Dissipation and Temperature

Symbol	Parameter	Min	Typ	Max	Unit
VCC_SYS	System Voltage	3.3	5	5.5	V
VCC3V3_SYS	System IO Voltage	3.3-5%	3.3	3.3+5%	V



Vrvpp	Max ripple Voltage			0.15	V
Isys_max	VCC_SYS input Max		1080	2450	mA
Ivio_max	VCC3V3_SYS input Max		300	550	mA
VCC_RTC	RTC IC	1.8	3	3.6	V
Irtc	RTC Current		5	8	uA
Ta	Operating Temperature	0		70	°C
Tstg	Storage Temperature	-40		85	°C

3.2 Reliability of Test

High Temperature Operating Test		
Contents	Operating 8 h in high temperature	55°C ± 2°C
Result	Pass	

Operating life Test		
Contents	Operating in room	120h
Result	Pass	



3.3 Certifications



Certificate of Conformity

NO.: ENS2112140001E00201C

The following product has been tested by us with the listed standards and found in conformity with the council EMC directive 2014/30/EU. This is to certify that the specimen is in conformity with the assessment requirement mentioned follow. This certificate does not imply assessment to the production of the product.

Applicant	: BOARDCON TECHNOLOGY LIMITED
Address	: ROOM702, XINAN BUSINESS BUILDING, 45ZONE, BAOAN DISTRCT
Manufacturer	: BOARDCON TECHNOLOGY LIMITED
Address	: ROOM702, XINAN BUSINESS BUILDING, 45ZONE, BAOAN DISTRCT
Trade Mark	: N/A
EUT	: CM3399 Core Board
M/N	: CM3399-V3
Test Standards	: EN 55032: 2015+A11:2020 EN IEC 61000-3-2: 2019 EN 61000-3-3: 2013+A1: 2019 EN 55035:2017+A11:2020
Version	: Ver.1.0

 (Manager)
 December 20, 2021

The certificate is based on a single evaluation of one sample of above-mentioned products, It does not imply an assessment of the whole production and does not permit the use of the test lab. logo.

EMTEK (Shenzhen) Co., Ltd.
 Add: Building 09, Majakong Industry Zone, Nanshan District, Shenzhen, Guangdong, China <http://www.emtek.com.cn> E-mail: cs.rep@emtek.com.cn

