

EM3399 Hardware Manual

V4.201910



Boardcon Embedded Design

www.boardcon.com

1. Introduction

1.1. About this Manual

This manual is intended to provide the user with an overview of the board and benefits, complete features specifications, and set up procedures. It contains important safety information as well.

1.2. Feedback and Update to this Manual

To help our customers make the most of our products, we are continually making additional and updated resources available on the Boardcon website (www.boardcon.com , www.armdesigner.com).

These include manuals, application notes, programming examples, and updated software and hardware. Check in periodically to see what's new!

When we are prioritizing work on these updated resources, feedback from customers is the number one influence, If you have questions, comments, or concerns about your product or project, please no hesitate to contact us at support@armdesigner.com.

1.3. Limited Warranty

Boardcon warrants this product to be free of defects in material and workmanship for a period of one year from date of buy. During this warranty period Boardcon will repair or replace the defective unit in accordance with the following process:

A copy of the original invoice must be included when returning the defective unit to Boardcon. This limited warranty does not cover damages resulting from lighting or other power surges, misuse, abuse, abnormal conditions of operation, or attempts to alter or modify the function of the product.

This warranty is limited to the repair or replacement of the defective unit. In no event shall Boardcon be liable or responsible for any loss or damages, including but not limited to any lost profits, incidental or consequential damages, loss of business, or anticipatory profits arising from the use or inability to use this product.

Repairs make after the expiration of the warranty period are subject to a repair charge and the cost of return shipping. Please contact Boardcon to arrange for any repair service and to obtain repair charge information.

Content

1 EM3399 Introduction	4
1.1 Summary	4
1.2 Rockchip RK3399 Features	4
1.3 EM3399 Specifications	5
1.4 PCB Dimension	7
1.5 Block Diagram	8
1.6 Development Kit Power Meter	8
1.7 CPU Introduction	8
2 Peripherals Introduction	25
2.1 Power (P1)	25
2.2 Audio I/O (J7)	25
2.3 HDMI IN (J6)	26
2.4 HDMI OUT (J4)	28
2.5 USB Type-C (J9)	29
2.6 USB HOST (P3, CON9)	30
2.7 Ethernet (JP1)	31
2.8 PCIe x4 (J5)	32
2.9 eDP Panel (CON3)	35
2.10 MIPI Panel (CON5)	36
2.11 MIPI (CON7, CON8)	37
2.12 Fan (J8)	40
2.13 Debug (J10)	40
2.14 GPIO (J2)	41
2.15 User Buttons (K1, K2, K3)	41
2.16 4G Module (CON2, P4)	41
2.17 Micro SD (J3)	44



2.18 WiFi&Bluetooth (U10)	45
2.19 RTC (BT1)	47
3 Product Configurations	47
3.1 Standard Contents	47
3.2 Optional Parts	48

1 EM3399 Introduction

1.1 Summary

The EM3399 is a hexa-core single-board computer based on Rockchip RK3399 processor with two Cortex A72 cores clocked at up to 1.8GHz, and four Cortex A53 cores teamed with a Mali-T860MP4 GPU, featuring 3G and WiFi/BT module, supporting 4K H.265 video decoding up to 60 fps, HDMI in/output, USB Type-C, Gigabit Ethernet, and target to 2 in1 Android tablets, VR, TV-BOX, laptops, in-vehicle navigations, communications and other terminals covering industrial and consumer applications, including smart Device, advertising devices / all-in-one machines, POS systems, vehicle control terminals, thin-clients, VOIP video conferencing security / monitoring / policing, IoT, as well as other fields.

EM3399 is implemented with a PICO3399 computer-on-module providing most of the functions and interfaces, and EM3399 carrier board providing connectors and several additional functions. The rich feature set of EM3399 is customizable according to the price / performance needs of the target application. EM3399 contains expansion connectors which accommodate a wide range of standard peripheral devices. Wide input range switched power supply is compatible with requirements for telecom and automotive applications. EM3399 is provided with full ready-to-run Android 7.1.2, Linux and debian SW packages and comprehensive user manual and designing guide.

1.2 Rockchip RK3399 Features

- **Microprocessor**
 - Dual-core ARM Cortex-A72 up to 1.8G.
 - Quad-core ARM Cortex-A53 up to 1.4G.
 - 1MB unified L2 Cache for Big cluster, 512KB unified L2 Cache for Little cluster.
- **Memory Organization**
 - On board memory
 - LPDDR4 up to 8GB.
 - EMMC5.1 up to 128GB.
 - External memory.
 - SPI NOR
- **Cortex-M0**
 - Two Cortex-M0 cooperate with Cortex-A72/Cortex-A53.

- Integrated sleep modes for low power consumption.
- Serial Wire Debug reduces the number of pins required for debugging.
- **PWM**
 - Four on-chip PWMs with interrupt-based operation.
 - Support capture mode and continuous mode or one-shot mode.
- **Watchdog**
 - Three Watchdogs in SoC with 32 bits counter width.
- **Interrupt Controller**
 - Support 8 PPI interrupt source and 148 SPI interrupt sources input.
 - Support 16 software-triggered interrupts.
- **3D Graphics Engine**
 - Arm Mali-T860MP4 GPU up to 4K supply.
 - High performance OpenGL ES1.1/2.0/3.0, OpenCL1.2, DirectX11.1 etc.
 - Provide MMU and L2 Cache with 256KB size
- **Power unit**
 - RK818 on board.
 - Compatible with multiple mode power supply.
 - Very low RTC consume current, less 7uA at 3V button Cell.
- **Temperature**
 - Less 46° run video play (exposed board at 20°).
 - Less 60° run AnTuTu test (exposed board at 20°)

1.3 EM3399 Specifications

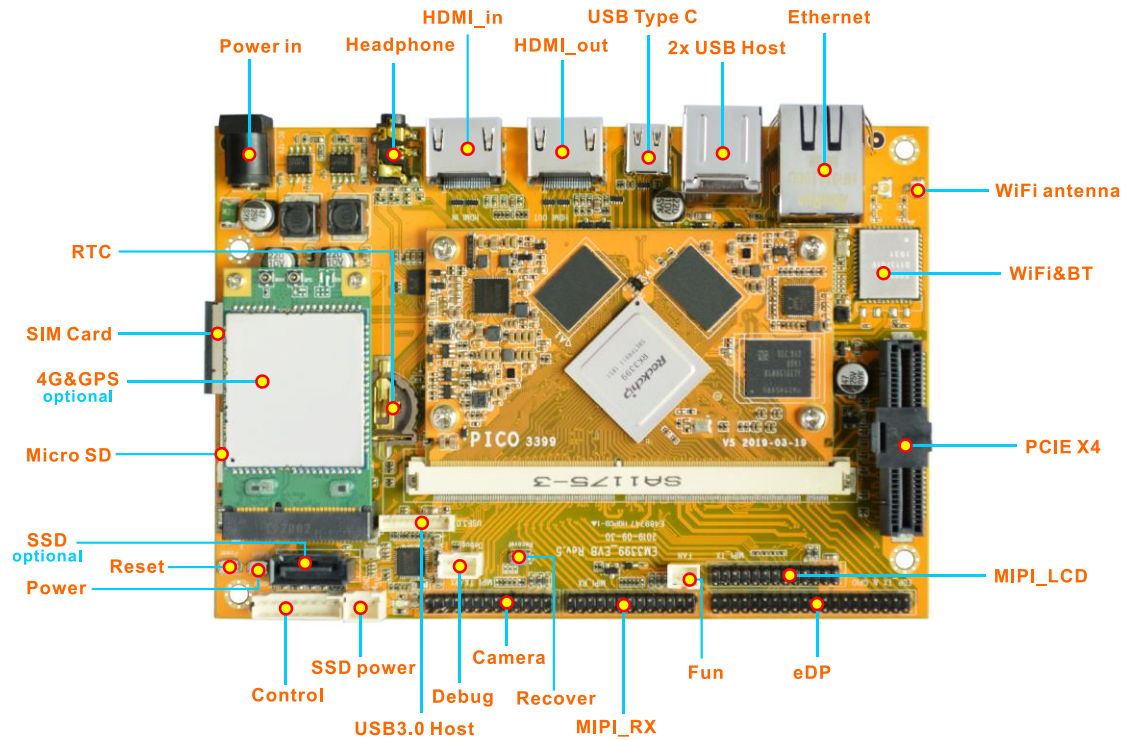

Feature	Specifications
CPU	Rockchip RK3399. 28nm HKMG process
GPU	Mali-T864 GPU
Memory	4GB LPDDR4
Flash	8GB eMMC Flash
Power	DC 12V/3A
USB	2x USB2.0 Host, 1x USB3.0 Host, 1x USB Type-C
UART	1x 3pin connector. For debug.
LCD	1x eDP LCD via 40-pin header interface, 1x 2-CH MIPI
Ethernet	1000M High performance Ethernet (RTL8211E), RJ45 interface
HDMI IN	Adopt Toshiba TC358749XBG bridge device
HDMI OUT	HDMI 1.4 /2.0
MIPI Camera	2-CH MIPI RX, Support 3-D video capture
Audio codec	Adopt ALC5651 Audio chip, 3.5mm Audio I / O interface

RTC	Real Time Clock, powered by external lithium battery
SD card	1x T-Flash card
SIM card	1x SIM card slot
Buttons	3x User Buttons, for Recover, Power, Reset
PCI-E x4	Can be used to connect adapter, such as USB, Network card, Disk array, etc
WIFI&BT	AP6356S Module. 2.4/5G WiFi, Bluetooth 4.1
3G/4G	PCI-E connector. Shared interface with SSD.
SSD	PCI-E connector. Shared interface with 3G/4G.
SATA	The SATA support SDSSDA 2.5" SSD Drive. Shared signal with PCI-E SSD.
GPIO	5 groups of GPIO (GPIO0~GPIO4), total 122 GPIOs
Dimension	100mm x 145mm

1.4 PCB Dimension

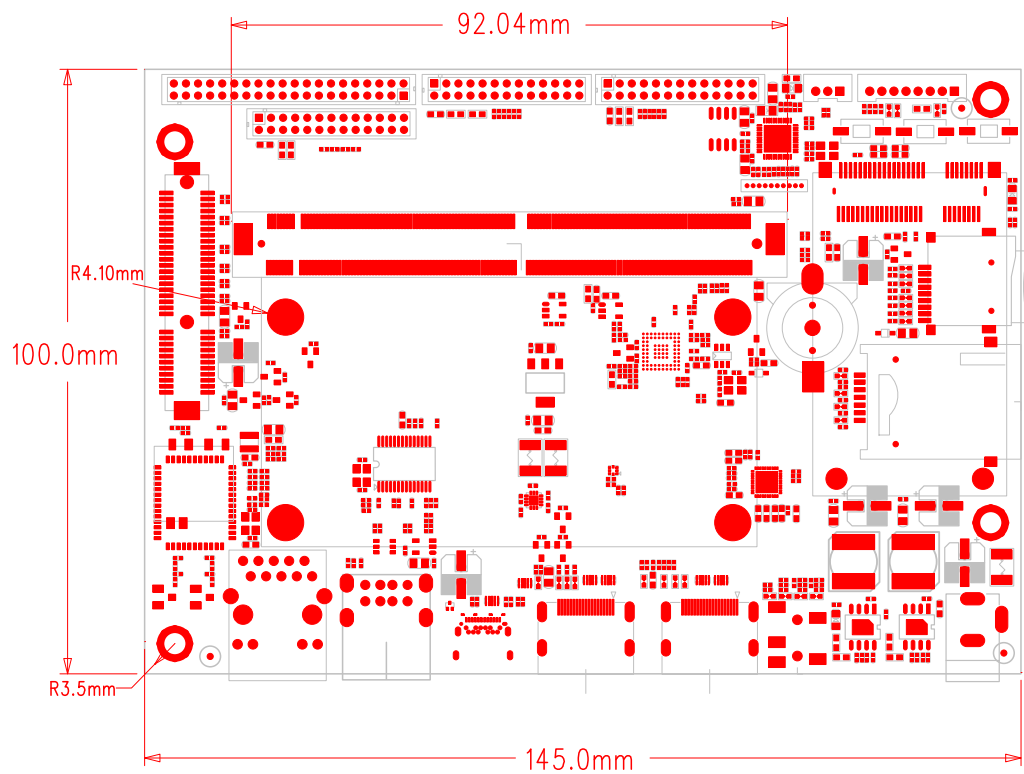

1.5 Block Diagram

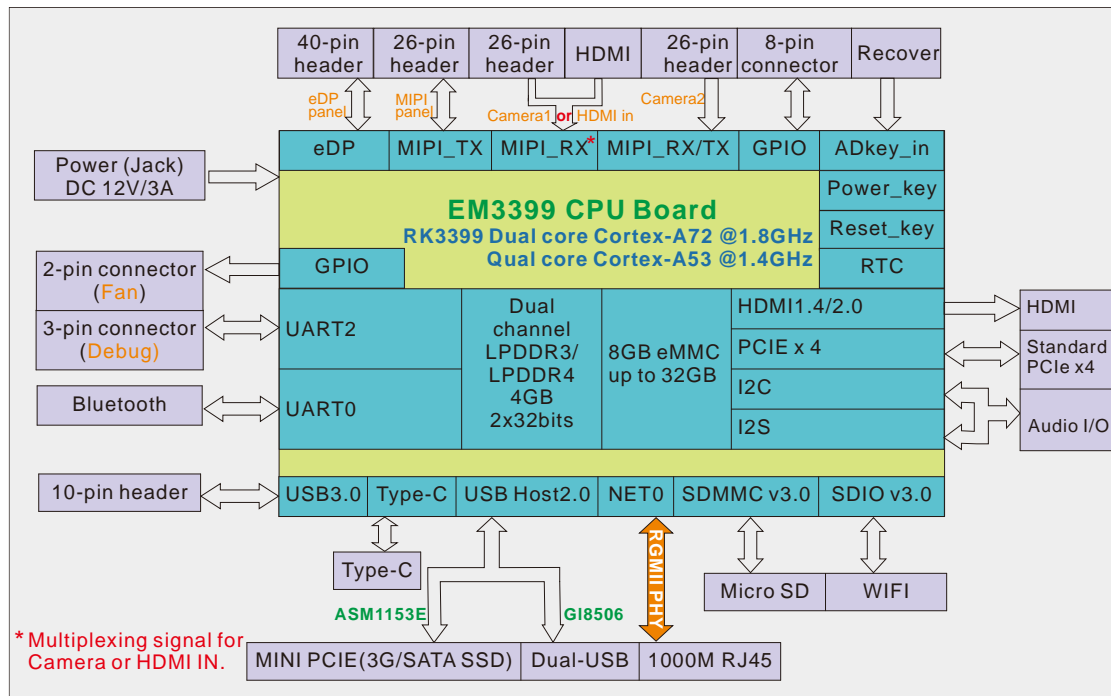

1.6 Development Kit Power Meter

Power	OS	Operation Temperature °C	Connected Devices	Electric Current (mA)
12V/3A	Android7.1.2	Room Temperature	Power, debug port	240
			Power, debug port, 10.1" MIPI LCD	480
			Power, debug port, 10.1" MIPI LCD, ethernet, U-disk, mouse, SD card, HDMI, WiFi&Bluetooth, 4G, Play 4k video	900

1.7 CPU Introduction

The CPU module PICO3399 features 4GB LPDDR4 RAM and 8GB eMMC Flash. MXM3.0-314P card edge interface.

[PICO3399 specifications](#)

Pin Definition

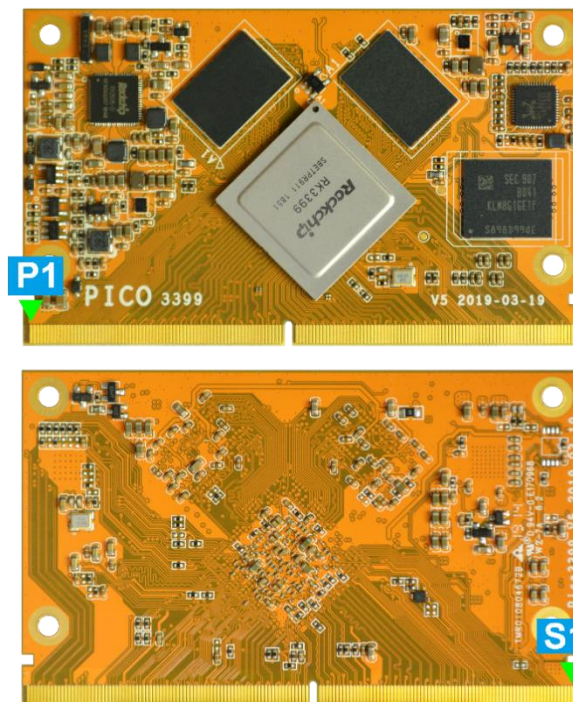

Pin	Signal	Function	Description / Alternate functions	IO Level
P1	VCC_SYS	Main Power Input	3.4-5.5V Wide power input	P

P2	VCC_SYS	Main Power Input	3.4-5.5V Wide power input	P
P3	VCC_SYS	Main Power Input	3.4-5.5V Wide power input	P
P4	VCC_SYS	Main Power Input	3.4-5.5V Wide power input	P
P5	AC_DET	EXT-AC detection in	Auto power on if connect P1	3.3-5.5V
P6	PMIC_EXT_EN	EXT-DCDC enable	To keep Peripheral turn on same time	O
P7	I2C1_SCL	I2C1 Bus Clock	GPIO4_A2	1.8V
P8	I2C1_SDA	I2C1 Bus Data	GPIO4_A1	1.8V
P9	I2S1_LRCK_RX	I2S1 LRCK input	GPIO4_A4_D	1.8V
P10	I2S1_SDO0	I2S1 Data0 output	GPIO4_A7_D	1.8V
P11	I2S0_SDO0	I2S0 Data0 output	GPIO3_D7_D	1.8V
P12	I2S0_SDO1	I2S0 Data1 output	GPIO3_D6_D	1.8V
P13	I2S1_LRCK_TX	I2S1 LRCK output	GPIO4_A5_D	1.8V
P14	I2S0_LRCK_TX	I2S0 LRCK output	GPIO3_D2_D	1.8V
P15	3V_GPIO4_C5	GPIO	3V_GPIO4_C5_D	3.0V
P16	I2S0_SDI0	I2S0 Data0 input	GPIO3_D3_D	1.8V
P17	3V3_UART2_RX	Debug UART RXD	GPIO4_C3_U	3.3V
P18	I2C_SCL_HDMI	I2C clock line for HDMI	GPIO4_C1_U	3.0V
P19	3V_GPIO4_D3	GPIO	3V_GPIO4_D3_D	3.0V
P20	TOUCH_RST_L	Touch screen reset	GPIO4_C6_D	3.0V
P21	3V_GPIO4_D1	GPIO	3V_GPIO4_D1_D	3.0V
P22	BT_WAKE_L	BT wake CPU in	GPIO2_D2_U or SDIO0 detection	1.8V
P23	SDIO0_D1	WIFI SDIO D1	GPIO2_C5_U or SPI5_TXD	1.8V
P24	UART0_RXD	UART receive data	GPIO2_C0_U	1.8V
P25	UART0_RTS	UART ready-to-send	GPIO2_C3_U	1.8V
P26	UART0_CTS	UART clear to send	GPIO2_C2_U	1.8V

P27	GND	Ground		0V
P28	MIPI_TX/RX_D0P	MIPI DSI or CSI	MIPI_TX1/RX1_D0P	1.8V
P29	MIPI_TX/RX_D0N	MIPI DSI or CSI	MIPI_TX1/RX1_D0N	1.8V
P30	GND	Ground		0V
P31	MIPI_TX/RX_D1P	MIPI DSI or CSI	TX1/RX1_D1P	1.8V
P32	MIPI_TX/RX_D1N	MIPI DSI or CSI	TX1/RX1_D1N	1.8V
P33	GND	Ground		0V
P34	MIPI_TX/RX_CLK P	MIPI DSI or CSI	TX1/RX1_CLKP	1.8V
P35	MIPI_TX/RX_CLK N	MIPI DSI or CSI	TX1/RX1_CLKN	1.8V
P36	GND	Ground		0V
P37	MIPI_TX/RX_D2P	MIPI DSI or CSI	TX1/RX1_D2P	1.8V
P38	MIPI_TX/RX_D2N	MIPI DSI or CSI	TX1/RX1_D2N	1.8V
P39	GND	Ground		0V
P40	MIPI_TX/RX_D3P	MIPI DSI or CSI	TX1/RX1_D3P	1.8V
P41	MIPI_TX/RX_D3N	MIPI DSI or CSI	TX1/RX1_D3N	1.8V
P42	GND	Ground		0V
P43	MIPI_RX_D3P	MIPI CSI	RX0_D3P	1.8V
P44	MIPI_RX_D3N	MIPI CSI	RX0_D3N	1.8V
P45	GND	Ground		0V
P46	MIPI_RX_D2P	MIPI CSI	RX0_D2P	1.8V
P47	MIPI_RX_D2N	MIPI CSI	RX0_D2N	1.8V
P48	GND	Ground		0V
P49	MIPI_RX_CLKP	MIPI CSI	MIPI_RX0_CLKP	1.8V
P50	MIPI_RX_CLKN	MIPI CSI	MIPI_RX0_CLKP	1.8V
P51	GND	Ground		0V
P52	MIPI_RX_D1P	MIPI CSI	MIPI_RX0_D1P	1.8V

P53	MIPI_RX_D1N	MIPI CSI	MIPI_RX0_D1N	1.8V
P54	GND	Ground		0V
P55	MIPI_RX_D0P	MIPI CSI	MIPI_RX0_D0P	1.8V
P56	MIPI_RX_D0N	MIPI CSI	MIPI_RX0_D0P	1.8V
P57	GND	Ground		0V
P58	TX_C-	HDMI TMDS Clock-	HDMI_TCN	1.8V
P59	TX_C+	HDMI TMDS Clock+	HDMI_TCP	1.8V
P60	GND	Ground		0V
P61	TX_0-	HDMI TMDS Data0-	HDMI_TX0N	1.8V
P62	TX_0+	HDM TMDS Data0+	HDMI_TX0P	1.8V
P63	GND	Ground		0V
P64	TX_1-	HDMI TMDS Data1-	HDMI_TX1N	1.8V
P65	TX_1+	HDMI TMDS Data1+	HDMI_TX1P	1.8V
P66	GND	Ground		0V
P67	TX_2-	HDMI TMDS Data2-	HDMI_TX2N	1.8V
P68	TX_2+	HDMI TMDS Data2+	HDMI_TX2P	1.8V
P69	GND	Ground		0V
P70	TYPEC0_RX1N	Receiver serial data -		1.8V
P71	TYPEC0_RX1P	Receiver serial data+		1.8V
P72	GND	Ground		0V
P73	TYPEC0_TX1P	Transmitter serial data +		1.8V
P74	TYPEC0_TX1N	Transmitter serial data -		1.8V
P75	TYPEC0_RX2N	Receiver serial data -		1.8V
P76	TYPEC0_RX2P	Receiver serial data+		1.8V
P77	GND	Ground		0V
P78	TYPEC0_TX2P	Transmitter serial data +		1.8V
P79	TYPEC0_TX2N	Transmitter serial data -		1.8V

P80	GND	Ground		0V
P81	TYPEC1_RX1N	Receiver serial data -		1.8V
P82	TYPEC1_RX1P	Receiver serial data+		1.8V
P83	GND	Ground		0V
P84	TYPEC1_TX1P	Transmitter serial data +		1.8V
P85	TYPEC1_TX1N	Transmitter serial data -		1.8V
P86	GND	Ground		0V
P87	TYPEC1_RX2N	Receiver serial data -		1.8V
P88	TYPEC1_RX2P	Receiver serial data+		1.8V
P89	GND	Ground		0V
P90	TYPEC1_TX2P	Transmitter serial data +		1.8V
P91	TYPEC1_TX2N	Transmitter serial data -		1.8V
P92	GND	Ground		0V
P93	TYPEC1_AUXM	AUX differential Tx serial data		1.8V
P94	TYPEC1_AUXP	AUX differential Rx serial data		1.8V
P95	GND	Ground		0V
P96	PCIE_RX1_P	PCIe differential data input signal +		1.8V
P97	PCIE_RX1_N	PCIe differential data input signal -		1.8V
P98	GND	Ground		0V
P99	PCIE_TX1P	PCIe differential data output signal +		1.8V
P100	PCIE_TX1N	PCIe differential data output signal -		1.8V
P101	GND	Ground		0V
P102	PCIE_RX0_P	PCIe differential data		1.8V

		input signal +		
P103	PCIE_RX0_N	PCle differential data input signal -		1.8V
P104	GND	Ground		0V
P105	PCIE_TX0P	PCle differential data output signal +		1.8V
P106	PCIE_TX0N	PCle differential data output signal -		1.8V
P107	GND	Ground		0V
P108	PCIE_REF_CLKN	Reference clock -	PCIE_RCLK_100M_N	1.8V
P109	PCIE_REF_CLKP	Reference clock +	PCIE_RCLK_100M_P	1.8V
P110	GND	Ground		0V
P111	HOST0_DP	USB host 0 data +		1.8V
P112	HOST0_DM	USB host 0 data -		1.8V
P113	GND	Ground		0V
P114	HOST1_DP	USB host 1 data +		1.8V
P115	HOST1_DM	USB host 1 data -		1.8V
P116	GND	Ground		0V
P117	GND	Ground		0V
P118	WIFI_REG_ON_H	WIFI Regulators power EN	GPIO0_B2_d	1.8V
P119	WIFI_HOST_WAK E_L	WIFI to wake-up HOST	GPIO0_A3/SDIO0_WRPT_d	1.8V
P120	GPIO0_B3	GPIO		1.8V
P121	GPIO1_A1	GPIO	ISP0_SHUTTER_TRIG/ISP1_ SHUTTER_TRIG/TCPD_CC0_ VCONN_EN_d	1.8V
P122	SPI1_TXD	SPI serial data output	GPIO1_B0/SPI1_TXD/UART4_ TX_u	1.8V
P123	I2C4_SDA	I2C data line	GPIO1_B3	1.8V

P124	I2C4_SCL	I2C serial clock line	GPIO1_B4	1.8V
P125	3V3_GPIO3_B2	GPIO3_B2_u	MAC_RXER/I2C5_SDA	3.3V
P126	GND	Ground		0V
P127	CIF_CLKOUT	Camera main clock output	GPIO2_B3/SPI2_CLK/VOP_D En	1.8V
P128	GND	Ground		0V
P129	CIF_D2	Camera interface input pixel data	GPIO2_A2/VOP_D2	1.8V
P130	CIF_D5	Camera interface input pixel data	GPIO2_A5/VOP_D5	1.8V
P131	CIF_D3	Camera interface input pixel data	GPIO2_A3/VOP_D3	1.8V
P132	CIF_D4	Camera interface input pixel data	GPIO2_A4/VOP_D4	1.8V
P133	CIF_D6	Camera interface input pixel data	GPIO2_A6/VOP_D6	1.8V
P134	GND	Ground		0V
P135	I2C2_SDA	I2C data line	GPIO2_A0/VOP_D0/CIF_D0	1.8V
P136	I2C7_SDA	I2C data line	GPIO2_A7/VOP_D7/CIF_D7	1.8V
P137	CIF_PDNO	CIF power ON/OFF	GPIO2_B4/SPI2_CSn0_u	1.8V
P138	GND	Ground		0V
P139	GND	Ground		0V
P140	eDP_TX3P	eDP data lane positive output		1.8V
P141	eDP_TX3N	eDP data lane negative output		1.8V
P142	GND	Ground		0V
P143	eDP_TX2P	eDP data lane positive output		1.8V
P144	eDP_TX2N	eDP data lane negative		1.8V

		output		
P145	GND	Ground		0V
P146	NC	Not connect		/
P147	NC	Not connect		/
P148	eDP_TX1P	eDP data lane positive output		1.8V
P149	eDP_TX1N	eDP data lane negative output		1.8V
P150	GND	Ground		0V
P151	eDP_TX0P	eDP data lane positive output		1.8V
P152	eDP_TX0N	eDP data lane negative output		1.8V
P153	GND	Ground		0V
P154	eDP_AXUP	eDP CH-AUX positive differential output		1.8V
P155	eDP_AXUN	eDP CH-AUX negative differential output		1.8V
P156	GND	Ground		0V
S1	VCC_SYS	Main Power Input	3.4-5.5V Wide power input	P
S2	VCC_SYS	Main Power Input	3.4-5.5V Wide power input	P
S3	VCC_SYS	Main Power Input	3.4-5.5V Wide power input	P
S4	VCC_SYS	Main Power Input	3.4-5.5V Wide power input	P
S5	VBuck	RTC Power Input	If not need, Can NC it.	3.0V
S6	GND	Ground		0V
S7	RTC_CLKO_WIFI	RTC CLK Output for WIFI	32.768KHz	1.8V
S8	GND	Ground		0V
S9	POWER_KEY	Key input	Single function	5V
S10	Reset_KEY	Key input	Single function	5V



S11	Reset_OUT	Main Reset Out	NC	/
S12	I2S0_SDO3	I2S serial data output	GPIO3_D4	1.8V
S13	I2S0_SCLK	I2S serial clock	GPIO3_D0	1.8V
S14	I2C1_SCLK	I2SC serial clock	GPIO4_A3	1.8V
S15	I2S1_SDI0	I2S serial data input	GPIO4_A6	1.8V
S16	I2S0_SDO2	I2S serial data output	GPIO3_D5_d /I2S0_SDI2SDO2	1.8V
S17	LCD_BL_PWM	Backlight PWM output	GPIO4_C2/PWM0/VOP0_PWM M/VOP1_PWM_d	3.0V
S18	I2S0_LRCK_RX	Left & right channel signal for receiving serial data	GPIO3_D1	1.8V
S19	3V_GPIO4_D0	GPIO4_D0_U	PCIE_CLKREQnB	3.0V
S20	PCIE_PRSENT		GPIO4_D6_d	3.0V
S21	3V_GPIO4_D2	GPIO	GPIO4_D2_d	3.0V
S22	GND	Ground		0V
S23	I2S_CLK	I2S clock	GPIO4_A0	1.8V
S24	GND	Ground		0V
S25	PCIE_PRSENT1#		GPIO4_D5_d	3.0V
S26	3V3_UART2_TX	UART serial data output		3.3V
S27	3V_GPIO4_D4	GPIO	GPIO4_D4_d	3.0V
S28	I2C_SDA_HDMI	I2C data line for HDMI	GPIO4_C0_u	3.0V
S29	HDMI_CEC	HDMI CEC signal	GPIO4_C7/EDP_HOTPLUG_u	3.0V
S30	GND	Ground		0V
S31	SDIO0_CLK	SDIO card clock	GPIO2_D1_u	1.8V
S32	GND	Ground		0V
S33	HDMI_HPD	HDMI hot plug detect input		3.3V
S34	GPIO2_D3	GIPO	SDIO0_PWREN_d	1.8V

S35	GPIO2_D4	GPIO	SDIO0_BKPWR_d	1.8V
S36	SDIO0_CMD	WIFI SDIO command output and response input	GPIO2_D0_u	1.8V
S37	SDIO0_D2	WIFI SDIO D2	GPIO2_C6/SPI5_CLK_u	1.8V
S38	SDIO0_D3	WIFI SDIO D3	GPIO2_C7/SPI5_CSn0_u	1.8V
S39	UART0_TXD	UART serial data output	GPIO2_C1_u	1.8V
S40	SDIO0_D0	WIFI SDIO D0	GPIO2_C4/SPI5_RXD_u	1.8V
S41	GND	Ground		0V
S42	MIPI_TX_D3N	MIPI DSI		1.8V
S43	MIPI_TX_D3P	MIPI DSI		1.8V
S44	GND	Ground		0V
S45	MIPI_TX_D2N	MIPI DSI		1.8V
S46	MIPI_TX_D2P	MIPI DSI		1.8V
S47	GND	Ground		0V
S48	MIPI_TX_CLKN	MIPI DSI Clock -		1.8V
S49	MIPI_TX_CLKP	MIPI DSI Clock +		1.8V
S50	GND	Ground		0V
S51	MIPI_TX_D1N	MIPI DSI		1.8V
S52	MIPI_TX_D1P	MIPI DSI		1.8V
S53	GND	Ground		0V
S54	MIPI_TX_D0N	MIPI DSI		1.8V
S55	MIPI_TX_D0P	MIPI DSI		1.8V
S56	GND	Ground		0V
S57	GND	Ground		0V
S58	VCC3V3_SYS	VCC_IO Output	For Peripheral used	3.3V
S59	VCC3V3_SYS	VCC_IO Output	For Peripheral used	3.3V
S60	VCC3V3_SYS	VCC_IO Output	For Peripheral used	3.3V

S61	VCC_EFUSE	eFuse program and sense power input	If not need, Can NC it.	1.8V
S62	VCC_EFUSE	eFuse program and sense power input	If not need, Can NC it.	1.8V
S63	GND	Ground		0V
S64	TYPEC0_AUXM	AUX differential Tx serial data		1.8V
S65	TYPEC0_AUXP	AUX differential Rx serial data		1.8V
S66	GND	Ground		0V
S67	TYPEC0_CC1	Configuration Channel1	NC it	/
S68	GND	Ground		0V
S69	TYPEC0_RCLKP	External reference clock	NC it	1.8V
S70	TYPEC0_RCLKN	External reference clock	NC it	1.8V
S71	GND	Ground		0V
S72	TYPEC0_CC2	Configuration Channel2	NC it	/
S73	GND	Ground		0V
S74	TYPEC0_DP	USB 2.0 data DP		1.8V
S75	TYPEC0_DM	USB 2.0 data DN		1.8V
S76	TYPEC1_DM	USB 2.0 data DN		1.8V
S77	TYPEC1_DP	USB 2.0 data DP		1.8V
S78	GND	Ground		0V
S79	ADKEY_IN	10bit ADC input signal	ADC_IN1	1.8V
S80	ADC_IN2	10bit ADC input signal	Need pull high.	1.8V
S81	ADC_IN3	10bit ADC input signal	Need pull high.	1.8V
S82	GND	Ground		0V
S83	TYPEC0_ID	USB 2.0 OTG ID detection	Input	3.3V
S84	TYPEC0_U2VBUS DET	VBUS BUMP into the PHY for VBUS monitor	TYPEC0 Vbus Input	3.3V



S85	GND	Ground		0V
S86	PCIE_RX3_N	PCIe differential data input		1.8V
S87	PCIE_RX3_P	PCIe differential data input		1.8V
S88	GND	Ground		0V
S89	PCIE_TX3P	PCIe differential data output		1.8V
S90	PCIE_TX3N	PCIe differential data output		1.8V
S91	GND	Ground		0V
S92	PCIE_RX2_N	PCIe differential data input signals		1.8V
S93	PCIE_RX2_P	PCIe differential data input		1.8V
S94	GND	Ground		0V
S95	PCIE_TX2P	PCIe differential data output		1.8V
S96	PCIE_TX2N	PCIe differential data output		1.8V
S97	GND	Ground		0V
S98	BT_HOST_WAKE_L	Bluetooth device to wake-up HOST	GPIO0_A4/SDIO0_INTn_d	1.8V
S99	SDMMC_D2	SDMMC card data input and output	GPIO4_B2/APJTAG_TCK_u	3.0V
S100	SDMMC_D0	SDMM card data input and output	GPIO4_B0/UART2A_RX_u	3.0V
S101	SDMMC_D1	SDMMC card data input and output	GPIO4_B1/UART2A_TX_u	3.0V
S102	SDMMC_CMD	SDMMC card command output and response input	GPIO4_B5/MCUJTAG_TMS_u	3.0V

S103	SDMMC0_DET_L	SDMMC card detect	GPIO0_A7_u	1.8V
S104	GND	Ground		0V
S105	SDMMC_CLK	SDMMC card clock	GPIO4_B4/MUCJTAG_TCK_d	3.0V
S106	GND	Ground		0V
S107	BT_REG_ON_H	Regulators power enable/disable	GPIO0_B1/PMUIO2_VOLSEL_d	1.8V
S108	SDMMC_D3	SDMMC card data input and output	GPIO4_B3/APJTAG_TMS_u	3.0V
S109	GPIO0_B0	GPIO	SDMMC0_WRPT/TEST_CLKOUT2_u	1.8V
S110	GPIO0_B5	GPIO	TCPD_VBUS_FDIS/TCPD_VBUS_SOURCE3_d	1.8V
S111	GPIO1_A4	GPIO	ISP0_PRELIGHT_TRIG/ISP1_PRELIGHT_TRIG_d	1.8V
S112	GPIO1_A2	GPIO	ISP0_FLASHTRIGIN/ISP1_FLASHTRIGIN/TCPD_CC1_VCONN_EN_d	1.8V
S113	GPIO1_A0	GPIO	ISP0_SHUTTER_EN/ISP1_SHUTTER_EN/TCPD_VBUS_SINK_EN_d	1.8V
S114	GPIO0_A6	GPIO	PWM3A_IR_d	1.8V
S115	GPIO1_A3	GPIO	ISP0_FLASHTRIGOUT/ISP1_FLASHTRIGOUT_d	1.8V
S116	SDMMC0_PWR_H		GPIO0_A1/DDRIO_PWROFF/TCPD_CCDB_EN_u	1.8V
S117	GND	Ground		0V
S118	SPI1_CLK	SPI serial clock	GPIO1_B1/PMCU_JTAG_TCK_u	1.8V
S119	SPI1_CS _{n0}	SPI first chip select signal	GPIO1_B2/PMCU_JTAG_TMS_u	1.8V
S120	PCIE_PERST#	Hot plug detect	GPIO1_C2/SPI3_CS _{n0} _u	1.8V

S121	PCIE_WAKE#	Link Reactivation	GPIO1_B5_d	1.8V
S122	GND	Ground		0V
S123	RK3399_26M_OUT	Cannot use for WIFI	GPIO0_A2_d	1.8V
S124	GND	Ground		0V
S125	SPI1_RXD	SPI serial data input	GPIO1_A7/UART4_RX_u	1.8V
S126	OTP_OUT_H	Over temperature signal out	GPIO1_A6/TSADC_INT_z	1.8V
S127	GPIO1_C6	GPIO	TCPD_VBUS_SOURCE0_d	1.8V
S128	GPIO1_D0	GPIO	TCPD_VBUS_SOURCE2_d	1.8V
S129	VCCA1V8_CODE C	Codec Power output	APIO5_VDDPST Max 300mA	1.8V
S130	GND	Ground		0V
S131	GND	Ground		0V
S132	I2C2_SCL	I2C serial clock line	GPIO2_A1/VOP_D1/CIF_D1	1.8V
S133	I2C7_SCL	I2C serial clock line	GPIO2_B0/VOP_CLK/CIF_VSYNC	1.8V
S134	I2C6_SDA	I2C data line	GPIO2_B1/SPI2_RXD/CIF_HREF	1.8V
S135	I2C6_SCL	I2C serial clock line	GPIO2_B2/SPI2_TXD/CIF_CLKIN	1.8V
S136	GND	Ground		0V
S137	GND	Ground		0V
S138	SPDIF_TX	S/PDIF biphasic data output	GPIO3_C0/MAC_COL/UART3_CTSn	3.3V
S139	GND	Ground		0V
S140	GND	Ground		0V
S141	LED0_AD0	Ethernet Link LED	PHYAD0	3.3V
S142	LED1_AD1	Ethernet Speed LED	PHYAD1	3.3V



S143	LED2_RXDLY	Receiver Clock Timing Control		3.3V
S144	GND	Ground		0V
S145	MDI0-	100M/1G Ethernet MDI0-		3.3V
S146	MDI0+	100M/1G Ethernet MDI0+		3.3V
S147	GND	Ground		0V
S148	NC	Not connect		/
S149	NC	Not connect		/
S150	MDI1-	100M/1G Ethernet MDI1-		3.3V
S151	MDI1+	100M/1G Ethernet MDI1+		3.3V
S152	GND	Ground		0V
S153	MDI2-	100M/1G Ethernet MDI2-		3.3V
S154	MDI2+	100M/1G Ethernet MDI2+		3.3V
S155	GND	Ground		0V
S156	MDI3-	100M/1G Ethernet MDI3-		3.3V
S157	MDI3+	100M/1G Ethernet MDI3+		3.3V
S158	GND	Ground		0V

2 Peripherals Introduction

2.1 Power (P1)

The DC JACK is 5.5 x 2.1mm, 3-pin plug Type. Typical 12V/3A DC adapter.

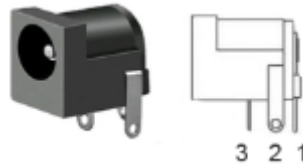

Pin	Signal	Description	Pin	Signal	Description
1	VDD12V	Main power supply. DC 12V power in	2	GND	Ground
3	GND	Ground			

2.2 Audio I/O (J7)

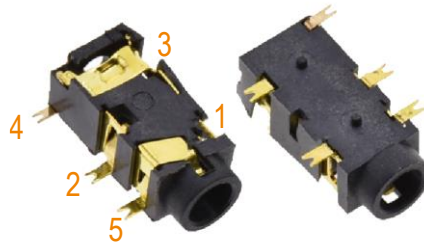

The EM3399 adopts audio codec ALC5651, provides stereo audio output/input. (PJ327E, 3.5mm Jack).

Feature

- Low power
- Integrated ADC and DAC
- IIS transfer audio data
- Stereo output, support recording

Pin	Signal	Description	Pin	Signal	Description
-----	--------	-------------	-----	--------	-------------

1	GND	Ground	2	HPO_R	Headphone amplifier output _Right channel
3	HPO_L	Headphone amplifier output _Left channel	4	PHE_DET	Headphone Detect
5	MIC2	Single-end input for microphone			

2.3 HDMI IN (J6)



Adopt Toshiba TC358749XBG bridge device. Regular 19pins HDMI type A, with width 13.9mm and thickness 4.45mm.

HDMI-RX Interface Features

- HDMI 1.4b
- Video Formats Support (Up to 1080p @60fps)
- RGB, YCbCr444: 24-bpp @60fps
- YCbCr422 24-bpp @60fps
- Audio Supports
- Internal Audio PLL to track N/CTS value transmitted by the ACR packet
- 3D Support
- HDCP1.4a Support
- EDID Support
- Release A, Revision 1 (Feb 9, 2000)
- First 128 byte (EDID 1.3 structure)
- First E-EDID Extension: 128 bytes of CEA Extension version 3 (specified in CEA-861-D)
- Embedded 1K-byte SRAM (EDID_SRAM)
- Maximum HDMI clock speed: 165 MHz

		Output	
--	--	--------	--

2.4 HDMI OUT (J4)



EM3399 supports up to 1080p at 120Hz and 4kx2k at 60Hz HDTV display resolutions. Single Physical Layer PHY with support for HDMI 1.4 and 2.0 operation

For HDMI operation, support for the following

- HPD input analog comparator
- 13.5–600MHz input reference clock
- Up to 10-bit Deep Color modes
- Up to 18Gbps aggregate bandwidth
- Up to 1080p at 120Hz and 4kx2k at 60Hz HDTV display resolutions and up to QXGA graphic display resolutions
- 3-D video formats
- Link controller flexible interface with 30-, 60- or 120-bit SDR data access
- Support HDCP 1.4/2.2

Pin	Signal	Description	Pin	Signal	Description
1	TX_2+	HDMI data 2 pair	2	GND	Ground
3	TX_2-		4	TX_1+	HDMI data 1 pair
5	GND	Ground	6	TX_1-	
7	TX_0+	HDMI data 0 pair	8	GND	Ground
9	TX_0-		10	TX_C+	HDMI clock pair
11	GND	Ground	12	TX_C-	
13	HDMI_CEC	Consumer electronics control	14	NC	Not connect

15	HDMI_SCL	HDMI serial clock	16	HDMI_SDA	HDMI serial data
17	GND	Ground	18	HDMI_VCC	5V power supply
19	HDMI_HPD	Hot Plug Detect			

2.5 USB Type-C (J9)

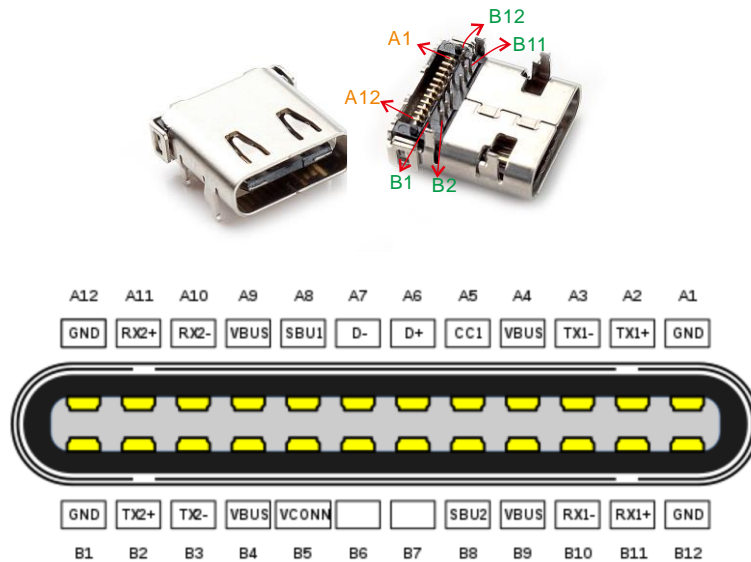

USB Type-C plug pinout end-on view

EM3399 Type-C is a USB3.1 port, it is used to download image and ADB transfer file, or use a docking station to connect HDMI, USB and ethernet device.

Feature

- Compliant with USB Type-C Specification, revision 1.1
- Compliant with USB Power Delivery Specification, revision 2.0
- Support USB3.0 Type-C and DisplayPort1.3 Alt Mode on USB Type-C
- Up to 5Gbps data rate for USB3.0
- Up to 5.4Gbps (HBR2) data rate for DP1.2, can support 1/2/4 lane mode

Pin	Signal	Description	Pin	Signal	Description
A1	GND	Ground	B1	GND	Ground
A2	TYPEC0_TX1P	Transmitter serial data +	B2	TYPEC0_TX2P	Transmitter serial data +
A3	TYPEC0_TX1	Transmitter serial data -	B3	TYPEC0_TX2N	Transmitter serial data -

	N				
A4	VBUS_TYPEC	VBUS BUMP into the PHY for VBUS monitor	B4	VBUS_TYPEC	VBUS BUMP into the PHY for VBUS monitor
A5	TYPECC1	Channel Configuration	B5	TYPECC2	Channel Configuration
A6	TYPECDP	USB 2.0 data DP	B6	TYPECDP	USB 2.0 data DP
A7	TYPECDM	USB 2.0 data DN	B7	TYPECDM	USB 2.0 data DN
A8	TYPECAUXP	AUX differential Tx serial data	B8	TYPECAUXM	AUX differential Tx serial data
A9	VBUS_TYPEC	VBUS BUMP into the PHY for VBUS monitor	B9	VBUS_TYPEC	VBUS BUMP into the PHY for VBUS monitor
A10	TYPECRX2N	Receiver serial data -	B10	TYPECRX1N	Receiver serial data -
A11	TYPECRX2P	Receiver serial data+	B11	TYPECRX1P	Receiver serial data+
A12	GND	Ground	B12	GND	Ground

2.6 USB HOST (P3, CON9)



EM3399 provides 2x USB2.0 Host(P3) and 1x USB3.0 Host(CON9).

USB2.0 Host is a dual-USB. The 2-ch USB HOST interfaces are extended by GL850G which is a fully compliant with the USB 2.0 hub specification and is designed to work with USB host as a high-speed hub. It is used to connect USB mouse, U disk, USB camera, and other USB devices, supports hot-plug.

USB3.0 Host is a 1.27mm pitch, 10-pin header.

Feature

- Supports high-speed (480Mbps), full-speed (12Mbps) and low-speed (1.5Mbps) mode
- Supports automatic switching between bus- and self-powered modes
- Provides 16 host mode channels
- Support periodic out channel in host mode

P3					
Pin	Signal	Description	Pin	Signal	Description
1	VCC_USB	USB Power. DC 5V	2	USB_DM2	USB data-
3	USB_DP2	USB Data+	4	GND	Ground
5	VCC_USB	USB Power. DC 5V	6	USB_DM4	USB data-
7	USB_DP4	USB Data+	8	GND	Ground
CON9					
Pin	Signal	Description	Pin	Signal	Description
1	VDD5V	5V power supply	2	GND	Ground
3	TYPEC1_DP	USB 2.0 data DP	4	TYPEC1_DM	USB 2.0 data DN
5	GND	Ground	6	TYPEC1_RX1N	Receiver serial data -
7	TYPEC1_RX1P	Receiver serial data +	8	GND	Ground
9	TYPEC1_TX1N	Transmitter serial data -	10	TYPEC1_TX1P	Transmitter serial data +

2.7 Ethernet (JP1)



EM3399 adopts RTL8211E as the Ethernet chip. RJ45 connector.

Feature

- Supports 10/100/1000-Mbps data transfer rates with the RGMII interfaces
- Supports both full-duplex and half-duplex operation
- Supports IEEE 802.1Q VLAN tag detection for reception frames

Pin	Signal	Description	Pin	Signal	Description
1	COM	Common	2	MDI0+	Bi-directional transmit/receive pair 0
3	MDI0-	Bi-directional transmit/receive pair 0	4	MDI1+	Bi-directional transmit/receive pair 1
5	MDI2+	Bi-directional transmit/receive pair2	6	MDI2-	Bi-directional transmit/receive pair2
7	MDI1-	Bi-directional transmit/receive pair 1	8	MDI3+	Bi-directional transmit/receive pair 3
9	MDI3-	Bi-directional transmit/receive pair 3	10	AGND	Ground
11	GLEDA	3.3V	12	GLEDK (LINK)	Detect link
13	YLEDK (GND)	Ground	14	YLEDA (SPEED)	Detect speed
15	GND	Ground	16	GND	Ground

2.8 PCIe x4 (J5)

The PCIE x4 can be used to connect adapter such as USB, Network card, Disk array, etc.

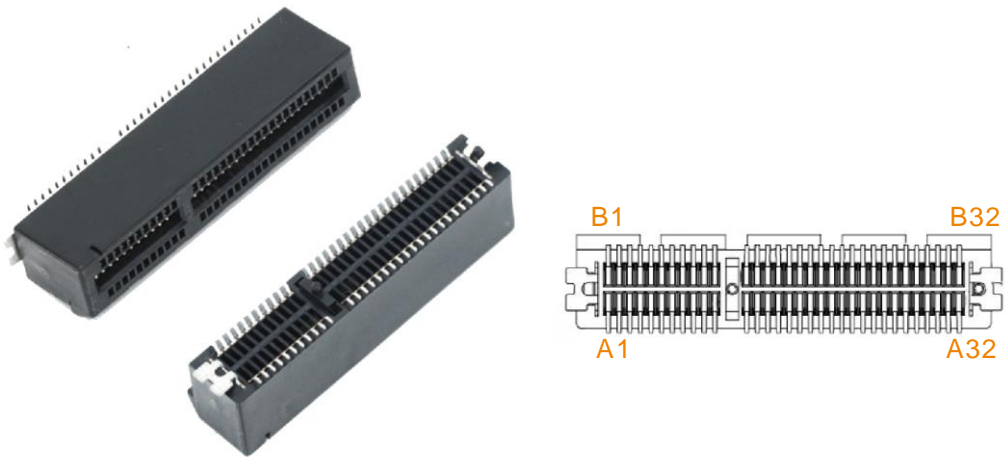

USB Adapter

Pin	Signal	Description	Pin	Signal	Description
A1	PCIE_PRSENT 1#	Hot plug presence detect	B1	PCIE_12V	12V power supply
A2	PCIE_12V	12V power supply	B2	PCIE_12V	12V power supply
A3	PCIE_12V	12V power supply	B3	NC	Not connect
A4	GND	Ground	B4	GND	Ground
A5	NC	Not connect	B5	I2C1_SCL_3V3	SMBus clock
A6	NC	Not connect	B6	I2C1_SDA_3V3	SMBus data

A7	NC	Not connect	B7	GND	Ground
A8	NC	Not connect	B8	PCIE_3V3	3.3V power supply
A9	PCIE_3V3	3.3V power supply	B9	NC	Not connect
A10	PCIE_3V3	3.3V power supply	B10	VCC3V3_SYS	3.3V power supply
A11	VCC3V3_SY S	3.3V power supply	B11	PCIE_WAKE#	Link Reactivation
A12	GND	Ground	B12	NC	Not connect
A13	PCIE_REF_C LK_P	Reference clock differential pair	B13	GND	Ground
A14	PCIE_REF_C LK_N		B14	PCIE_TX0P	Transmit data +
A15	GND	Ground	B15	PCIE_TX0N	Transmit data -
A16	PCIE_RX0_P	Receive data +	B16	GND	Ground
A17	PCIE_RX0_N	Receive data -	B17	PCIE_PRSENTx 1	Hot plug detect
A18	GND	Ground	B18	GND	Ground
A19	GND	Ground	B19	PCIE_TX1P	Transmit data +
A20	PCIE_RX1_P	Receive data +	B20	PCIE_TX1N	Transmit data -
A21	PCIE_RX1_N	Receive data -	B21	GND	Ground
A22	GND	Ground	B22	GND	Ground
A23	GND	Ground	B23	PCIE_TX2P	Transmit data +
A24	GND	Ground	B24	PCIE_TX2N	Transmit data -
A25	PCIE_RX2_P	Receive data +	B25	GND	Ground
A26	PCIE_RX2_N	Receive data -	B26	GND	Ground
A27	GND	Ground	B27	PCIE_TX3P	Transmit data +
A28	GND	Ground	B28	PCIE_TX3N	Transmit data -
A29	PCIE_RX3_P	Receive data +	B29	GND	Ground
A30	PCIE_RX3_N	Receive data -	B30	NC	Not connect

A31	GND	Ground	B31	PCIE_PRSENTx 4	Hot plug detect
A32	NC	Not connect	B32	GND	Ground

2.9 eDP Panel (CON3)

EM3399 supports 12.4-inch HD capacitive LCD.

eDP PHY Feature

- Compliant with eDPTM Specification, version 1.3
- Support RGB 6/8/10bit video format
- Up to 4 physical lanes of 2.7/1.62 Gbps/lane
- Support VESA DMT and CVT timing standards
- Fully support EIA/CEA-861D video timing and Info Frame structure
- Hot plug and unplug detection and link status monitor
- Supports Panel Self Refresh (PSR)

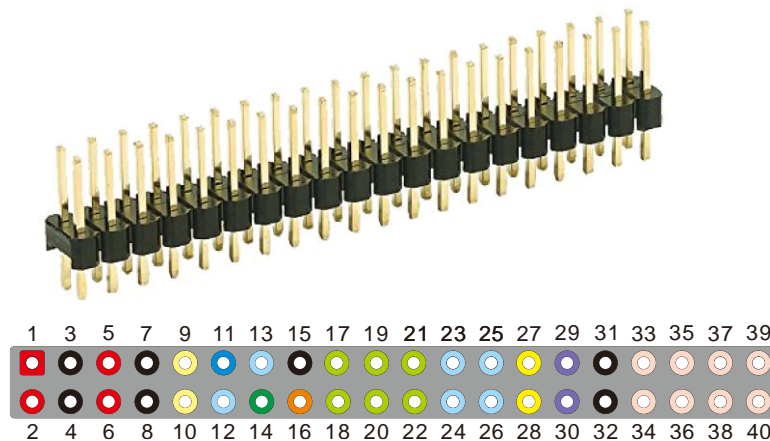

Pin	Signal	Description	Pin	Signal	Description
1	PWIN	Power in. 12V power supply	2	PWIN	Power in. 12V power supply
3	GND	Ground	4	GND	Ground
5	VCC3V3_SYS	3.3V power supply	6	VDDIO_18	1.8V power supply
7	GND	Ground	8	GND	Ground

9	I2C6_SCL	I2C serial clock line	10	I2C6_SDA	I2C data line
11	TOUCH_RST_L	Touch screen reset	12	GPIO3_D4	GPIO
13	3V3_GPIO3_B2	GPIO	14	LCD_BL_PWM	Backlight PWM output
15	GND	Ground	16	SPDIF_TX	S/PDIF biphas data output
17	ADC_IN2	10bit ADC input signal	18	ADC_IN3	10bit ADC input signal
19	SPI1_RXD	SPI serial data input	20	SPI1_CSn0	SPI first chip select signal
21	SPI1_CLK	SPI serial clock	22	SPI1_TXD	SPI serial data output
23	GPIO2_A2	GPIO	24	GPIO2_A3	GPIO
25	GPIO2_A4	GPIO	26	GPIO2_A5	GPIO
27	I2C7_SCL	I2C serial clock line	28	I2C7_SDA	I2C data line
29	eDP_AXUP	eDP CH-AUX positive differential output	30	eDP_AXUN	eDP CH-AUX negative differential output
31	GND	Ground	32	GND	Ground
33	EDP_TX3P	eDP data lane positive output	34	EDP_TX3N	eDP data lane negative output
35	EDP_TX2P	eDP data lane positive output	36	EDP_TX2N	eDP data lane negative output
37	EDP_TX1P	eDP data lane positive output	38	EDP_TX1N	eDP data lane negative output
39	EDP_TX0P	eDP data lane positive output	40	EDP_TX0N	eDP data lane negative output

2.10 MIPI Panel (CON5)

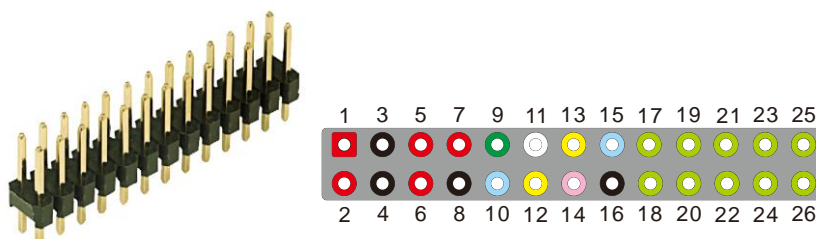

EM3399 adopts 10.1-inch MIPI panel, resolution 1280 x 800.

Pin	Signal	Description	Pin	Signal	Description
1	VDD5V	5V power supply	2	VDD5V	5V power supply
3	GND	Ground	4	GND	Ground
5	VCC3V3_SYS	3.3V power supply	6	VCC3V3_SYS	3.3V power supply
7	VDDIO_18	1.8V power supply	8	GND	Ground
9	LCD_BL_PWM	Backlight PWM output	10	3V3_GPIO3_B2	GPIO
11	SPDIF_TX	S/PDIF biphasic data output	12	I2C6_SCL	I2C serial clock line
13	I2C6_SDA	I2C data line	14	TOUCH_RST_L	Touch screen reset
15	GPIO3_D4	GPIO	16	GND	Ground
17	MIPI_TX_D0N	MIPI DSI negative differential data line transceiver output	18	MIPI_TX_D0P	MIPI DSI positive differential data line transceiver output
19	MIPI_TX_D1N	MIPI DSI negative differential data line transceiver output	20	MIPI_TX_D1P	MIPI DSI positive differential data line transceiver output
21	MIPI_TX_CLKN	MIPI DSI negative differential clock line transceiver output	22	MIPI_TX_CLKP	MIPI DSI positive differential clock line transceiver output
23	MIPI_TX_D2N	MIPI DSI negative differential data line transceiver output	24	MIPI_TX_D2P	MIPI DSI positive differential data line transceiver output
25	MIPI_TX_D3N	MIPI DSI negative differential data line transceiver output	26	MIPI_TX_D3P	MIPI DSI positive differential data line transceiver output

2.11 MIPI (CON7, CON8)

EM3399 features two 26-pin MIPI connectors.

Features

- Embedded 3 MIPI PHY, MIPI 0 only for TX use for MIPI LCD, MIPI 1 for TX and RX use for camera, MIPI 2 only for RX
- Support 4 data lane, providing up to 6Gbps data rate
- Support 1080p@60fps output
- Lane operation ranging from 80 Mbps to 1.5Gbps in forward direction.

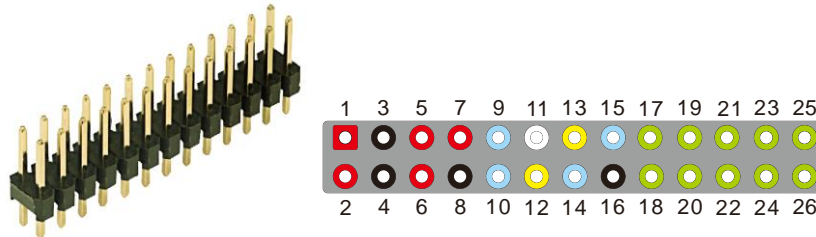

CON7					
Pin	Signal	Description	Pin	Signal	Description
1	VDD5V	5V power supply	2	VDD5V	5V power supply
3	GND	Ground	4	GND	Ground
5	VCC3V3_SYS	3.3V power supply	6	VCC3V3_SYS	3.3V power supply
7	VDDIO_18	1.8V power supply	8	GND	Ground
9	GPIO1_A0	GPIO	10	GPIO1_A1	GPIO
11	MIPI_MCLK1	MIPI main clock 1 output	12	I2C2_SCL	I2C serial clock line
13	I2C2_SDA	I2C data line	14	GPIO1_C6	GPIO
15	GPIO1_D0	GPIO	16	GND	Ground
17	MIPI_RX_CLKN	MIPI CSI negative differential clock line transceiver output	18	MIPI_RX_CLKP	MIPI CSI positive differential clock line transceiver output
19	MIPI_RX_D0N	MIPI CSI negative differential data line transceiver output	20	MIPI_RX_D0P	MIPI CSI positive differential data line transceiver output
21	MIPI_RX_D1N	MIPI CSI negative differential data line transceiver output	22	MIPI_RX_D1P	MIPI CSI positive differential data line transceiver output

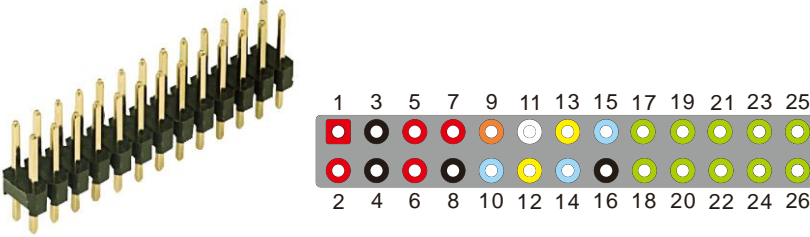
23	MIPI_RX_D2N	MIPI CSI negative differential data line transceiver output	24	MIPI_RX_D2P	MIPI CSI positive differential data line transceiver output
25	MIPI_RX_D3N	MIPI CSI negative differential data line transceiver output	26	MIPI_RX_D3P	MIPI CSI positive differential data line transceiver output
					
CON8 (Camera)					
Pin	Signal	Description	Pin	Signal	Description
1	VDD5V	5V power supply	2	VDD5V	5V power supply
3	GND	Ground	4	GND	Ground
5	VCC3V3_SYS	3.3V power supply	6	VCC3V3_SYS	3.3V power supply
7	VDDIO_18	1.8V power supply	8	GND	Ground
9	CIF_PDN0	CIF power ON/OFF	10	3V_GPIO4_D0	GPIO
11	MIPI_MCLK0	Camera main clock 0 output	12	I2C4SCL_BCLK	I2C serial clock line
13	I2C4SDA_LRCK	I2C data line	14	GPIO3D5_DACDAT	GPIO
15	GPIO3D6_MCLK	GPIO	16	GND	Ground
17	MIPI_TX/RX_CLKN	MIPI CSI negative differential clock line transceiver output	18	MIPI_TX/RX_CLKP	MIPI CSI positive differential clock line transceiver output
19	MIPI_TX/RX_D0N	MIPI CSI negative differential data line transceiver output	20	MIPI_TX/RX_D0P	MIPI CSI positive differential data line transceiver output
21	MIPI_TX/RX_D1	MIPI CSI negative differential data line	22	MIPI_TX/RX_D1	MIPI CSI positive differential data line

	N	transceiver output		1P	transceiver output
23	MIPI_TX/RX_D2 N	MIPI CSI negative differential data line transceiver output	24	MIPI_TX/RX_D 2P	MIPI CSI positive differential data line transceiver output
25	MIPI_TX/RX_D3 N	MIPI CSI negative differential data line transceiver output	26	MIPI_TX/RX_D 3P	MIPI CSI positive differential data line transceiver output

2.12 Fan (J8)

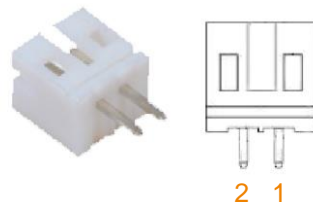

2-pin connector. It is used to connect the fan to cool down

Pin	Signal	Description	Pin	Signal	Description
1	GPIO0_A6	GPIO	2	PWIN	Power in. 12V power supply

2.13 Debug (J10)



3-pin connector. The debug serial port baud rate is 1500000.

Pin	Signal	Description	Pin	Signal	Description
1	UART2DBG_RX	UART serial data input	2	UART2DBG_TX	UART serial data output
3	GND	Ground			

2.14 GPIO (J2)

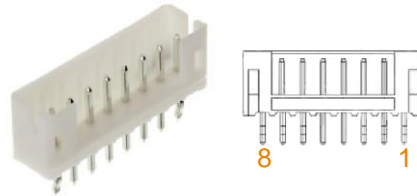

8-pin connector

Pin	Signal	Description	Pin	Signal	Description
1	VCC3V3_SYS	3V power supply	2	GND	Ground
3	RECOVER/ ADKEY_IN	Recover/ AD_in	4	PWR-KEY	Power
5	GND	Ground	6	IR_IN/ GPIO0_A6	IR_in/GPIO
7	WORK_LED/ GPIO2_D4	LED/GPIO	8	PWR_LED/ GPIO2_D3	LED/GPIO

2.15 User Buttons (K1, K2, K3)

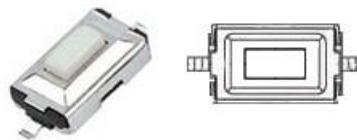

Key	Signal	Description	Key	Signal	Description
K1	POWER_KEY	Power	K2	Reset_KEY	Reset
K3	RECOVER	Recover			

2.16 4G Module (CON2, P4)

EM3399 adopts the standard PCI Express® MiniCard form factor (MiniPCIe) and provides global network coverage on the connectivity of LTE. It delivers 50Mbps-up and 100Mbps-down data rates on LTE FDD networks and can also be fully backward compatible with existing UMTS and GSM/GPRS networks.

35	GND	Ground	36	HOST1_DM	Host data DN
37	GND	Ground	38	HOST1_DP	Host data DP
39	3GVCC	DC 3.3V	40	GND	Ground
41	3GVCC	DC 3.3V	42	LED_WWAN	LED
43	GND	Ground	44	NC	Not connect
45	NC	Not connect	46	NC	Not connect
47	NC	Not connect	48	NC	Not connect
49	NC	Not connect	50	GND	Ground
51	NC	Not connect	52	3GVCC	DC 3.3V

The PCIE is share with SSD (mSATA).



P4 is an auto pop-up SIM card slot which is compatible to the standard SIM Card and can be used for wireless transmission with a 3G/4G module.

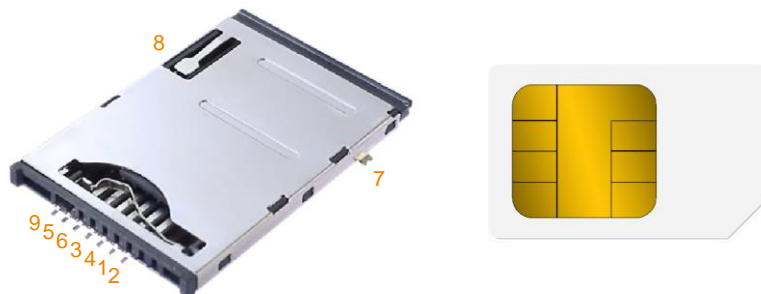

SIM Card slot (P4)					
Pin	Signal	Description	Pin	Signal	Description

1	SIM_CLK	Clock	2	SIM_DATA	send/receiver data I/O control
3	SIM_RST	Reset	4	SIM_VCC	Connect to CON5
5	SIM_VCC	Connect to CON5	6	GND	Ground
7	GND	Ground	8	GND	Ground
9	GND	Ground			

2.17 Micro SD (J3)

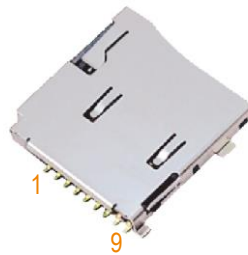

The Micro SD card is used as an external storage device. The MMC controller interface supports up to 4-bit transfer modes. MMC is always accessible through the carrier board interface.

Pin	Signal	Description	Pin	Signal	Description
1	SDMMC_D2	SD/MMC data2	2	SDMMC_D3	SD/MMC data3
3	SDMMC_CMD	SD/MMC command signal	4	VCCIO_SD	3.3V
5	SDMMC_CLK	SD/MMC clock	6	GND	Ground
7	SDMMC_D0	SD/MMC data0	8	SDMMC_D1	SD/MMC data1
9	SDMMC_DET_L	SD/MMC detect signal	10	GND	Ground
11	GND	Ground	12	GND	Ground

2.18 WiFi&Bluetooth (U10)

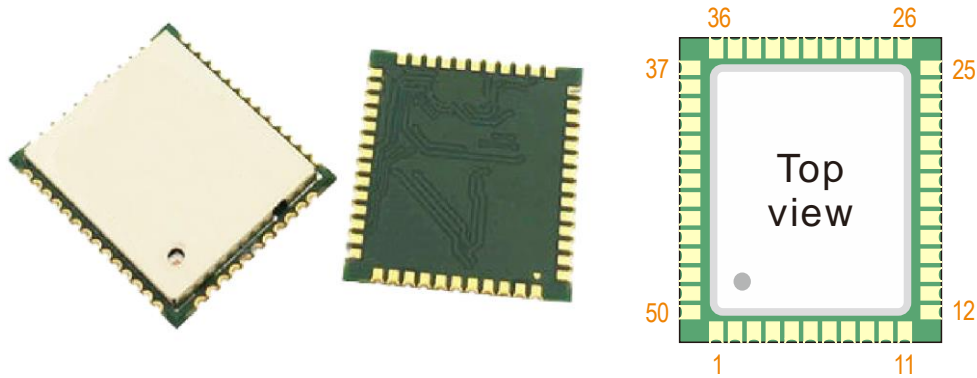

AP6356S is a low-power consumption module which has incorporated Wi-Fi and Bluetooth into one chip. The module complies with IEEE 802.11 a/b/g/n/ac standard and it could achieve up to a speed of 72.2Mbps with single stream in 802.11n draft, 54Mbps as specified in 802.11g, or 11Mbps for 802.11b to connect to the wireless LAN. The integrated module provides SDIO interface for WiFi, UART / PCM for Bluetooth.

Features

- 802.11a/b/g/n/ac dual-band radio with virtual-simultaneous dual-band operation
- Dual-stream spatial multiplexing up to 867 Mbps data rate.
- Supports 20, 40, 80 MHz channels with optional SGI (256 QAM modulation)
- Supports IEEE 802.11 ac/n beam forming.
- Supports IEEE 802.15.2 external coexistence interface to property
- With other co-located wireless technologies such as LTE, GPS, or WiMAX.
- BT host digital interface:
 - HCI UART (up to 4 Mbps)
 - PCM for audio data
- Complies with Bluetooth Core Specification Version 4.1 with provisions for supporting

Pin	Signal	Description	Pin	Signal	Description
1	GND	Ground	2	WL/BT_ANT0	WiFi/Bluetooth Antenna
3	GND	Ground	4	GND	Ground
5	GND	Ground	6	GND	Ground

7	GND	Ground	8	GND	Ground
9	WL_ANT1	WIFI Antenna	10	GND	Ground
11	GND	Ground	12	NC	Not connect
13	XTAL_IN	External Crystal in	14	XTAL_OUT	External Crystal out
15	WIFI_REG_ON_H	Low asserting reset for WiFi core	16	WIFI_HOST_WAK_E_L	WLAN to wake-up HOST
17	SDIO_CMD	SDIO command	18	SDIO_CLK	SDIO clock
19	SDIO_D3	SDIO data	20	SDIO_D2	SDIO data
21	SDIO_D0	SDIO data	22	SDIO_D1	SDIO data
23	GND	Ground	24	NC	Not connect
25	VIN_LDO	Internal Buck voltage generation pin	26	VIN_LDO_OUT	Internal Buck voltage generation pin
27	BT_PCM_SYNC	PCM sync signal	28	BT_PCM_IN	PCM data input
29	BT_PCM_OUT	PCM Data output	30	BT_PCM_CLK	PCM clock
31	RTC_CLKO_WIFI	External Low Power Clock input (32.768KHz)	32	GND	Ground
33	NC	Not connect	34	VDDIO_WL	I/O Voltage supply input
35	NC	Not connect	36	VCC_WL	Main power voltage source input
37	NC	Not connect	38	BT_REG_ON_H	Low asserting reset for Bluetooth core
39	GND	Ground	40	UART0_RXD	Bluetooth UART interface
41	UART0_TXD	Bluetooth UART interface	42	UART0_CTS	Bluetooth UART interface
43	UART0_RTS	Bluetooth UART	44	NC	Not connect

		interface			
45	NC	Not connect	46	NC	Not connect
47	NC	Not connect	48	NC	Not connect
49	BT_WAKE_L	HOST wake-up Bluetooth device	50	BT_HOST_WAKE _L	Bluetooth device to wake-up HOST

2.19 RTC (BT1)



The backup battery (3V) is used to ensure the RTC (frequency 32.768KHz) is still able to work after power off. Lithium cell model: CR1220.

Pin	Signal	Description	Pin	Signal	Description
1	VBuck	3V battery	2	GND	Ground

3 Product Configurations

3.1 Standard Contents

NO.	Item	Qty. (PCS)	Description
1	EM3399 board	1	Standard Content (4GB RAM, 8GB eMMC)
2	TF card / CD-ROM	1	Android/Debian BSP, Ubuntu BSP, Documents, tools, Schematic Drawing, datasheets
3	Ethernet cable	1	
4	Serial Cable	1	CP2102
5	USB Cable	1	USB Type-C
6	Power adaptor	1	12V/3A DC

3.2 Optional Parts

- MIPI camera Module (OV13850)
- LCD Module (10.1-inch MIPI panel)
- 4G Module
- SSD