



BOARDCON
Embedded Design

V2. 202503

EM3576

Hardware User Manual

Rockchip RK3576 Octa-core platform

Boardcon Embedded Design

ODM dedicated to providing high quality
Single Board Computer and System-on-Module



1. Introduction

1.1. About this Manual

This manual is intended to provide the user with an overview of the board and benefits, complete features specifications, and set up procedures. It contains important safety information as well.

1.2. Feedback and Update to this Manual

To help our customers make the most of our products, we are continually making additional and updated resources available on the Boardcon website (www.boardcon.com , www.armdesigner.com).

These include manuals, application notes, programming examples, and updated software and hardware. Check in periodically to see what's new!

When we are prioritizing work on these updated resources, feedback from customers is the number one influence, If you have questions, comments, or concerns about your product or project, please no hesitate to contact us at support@armdesigner.com.

1.3. Limited Warranty

Boardcon warrants this product to be free of defects in material and workmanship for a period of one year from date of buy. During this warranty period Boardcon will repair or replace the defective unit in accordance with the following process:

A copy of the original invoice must be included when returning the defective unit to Boardcon. This limited warranty does not cover damages resulting from lighting or other power surges, misuse, abuse, abnormal conditions of operation, or attempts to alter or modify the function of the product.

This warranty is limited to the repair or replacement of the defective unit. In no event shall Boardcon be liable or responsible for any loss or damages, including but not limited to any lost profits, incidental or consequential damages, loss of business, or anticipatory profits arising from the use or inability to use this product.

Repairs make after the expiration of the warranty period are subject to a repair charge and the cost of return shipping. Please contact Boardcon to arrange for any repair service and to obtain repair charge information.

Content

1 EM3576 Introduction	3
1.1 Summary	3
1.2 RK3576 Specifications	3
1.3 EM3576 Features	4
1.4 PCB Dimension	5
1.5 Block Diagram	6
1.6 CPU module Introduction	7
2 Peripherals Introduction	20
2.1 Power (P1)	20
2.2 Audio I/O	20
2.3 HDMI OUT (J21)	21
2.4 USB Type-C (J51)	22
2.5 USB HOST (J12)	23
2.6 SATA (J6, J8)	24
2.7 Ethernet (JP1)	25
2.8 MIPI Panel (CON4)	25
2.9 LCDC-RGB888 (J10: Option)	26
2.10 GPIO (J9)	27
2.11 Camera (J24, J25, J26, J27, J28, J29)	28
2.12 UART (J1, J18, J19)	29
2.13 RS485 (J52)	30
2.14 CAN (J15)	30
2.15 Button (SW1, SW2, SW3)	31
2.16 Micro SD CARD (J3)	31
2.17 WiFi&Bluetooth (U12)	32
2.18 SSD (J7)	34
2.19 SPI (J14)	35
2.20 NFC (J17)	36
2.21 RTC (J2)	36
3 Product Configurations	37
3.1 Standard Contents	37
3.2 Optional Parts	37

1 EM3576 Introduction

1.1 Summary

The EM3576 is a single-board computer powered by Rockchip RK3576 processor featuring 4x Cortex-A72 cores @ 2.2 GHz and 4x Cortex-A53 cores @ 1.8 GHz. It designed for 8nm AIoT applications including industrial automation, security surveillance, intelligent transportation, medical electronics, and more.

This SBC features 4GB memory (up to 8GB), 32GB(up to 128GB) comes with MIPI, HDMI video out, and offers Gigabit Ethernet port, as well as SATA3.1/M.2/Micro SD expansion storage interface. supports connecting up to 12x AHD cameras. Combined with the built-in 6TOPS NPU. It introduces a new generation 16-Megapixel ISP (Image Signal Processor). It implements a lot of algorithm accelerators.

It supports H.264, H.265, VP9, AV1 and AVS2 etc. up to 8K@30fps or 4K@120fps video decoder and H.264 and H.265 up to 4K@60fps video encode.

1.2 RK3576 Specifications

Feature	Specifications
SOC	Rockchip RK3576
CPU	Quad-core Cortex A72 MPCore processor and Quad-core Cortex A53 MPcore processor with separately NEON Coprocessor
GPU	ARM Mali G52 MC3 GPU Supports OpenGL ES 1.1/2.0/3.2. OpenCL 2.0. Vulkan 1.1 Embedded high-performance 2D Graphics Engine(RGA) Supports VDPP(Video & Display Post Process)
NPU	6TOPS* for INT8 Supports dual core and support dual core co-work, or work independently Supports INT4, INT8, INT16, FP16, BF16 AND TF32 operation Supports 1MB internal SRAM Supports multi-task, multi-scenario in parallel Supports deep learning frameworks
VPU	Supports 4K 60fps H.264/AVC, H264 MVC video decoding Supports 8K 30fps or 4K@120fps H.265/HEVC, VP9, AVS2, AV1 video decoding Supports 4K 60fps H.265/H.264 video encoding Supports MJPG up to 4K@60fps JPEG Encoder/JPEG Decoder

1.3 EM3576 Features

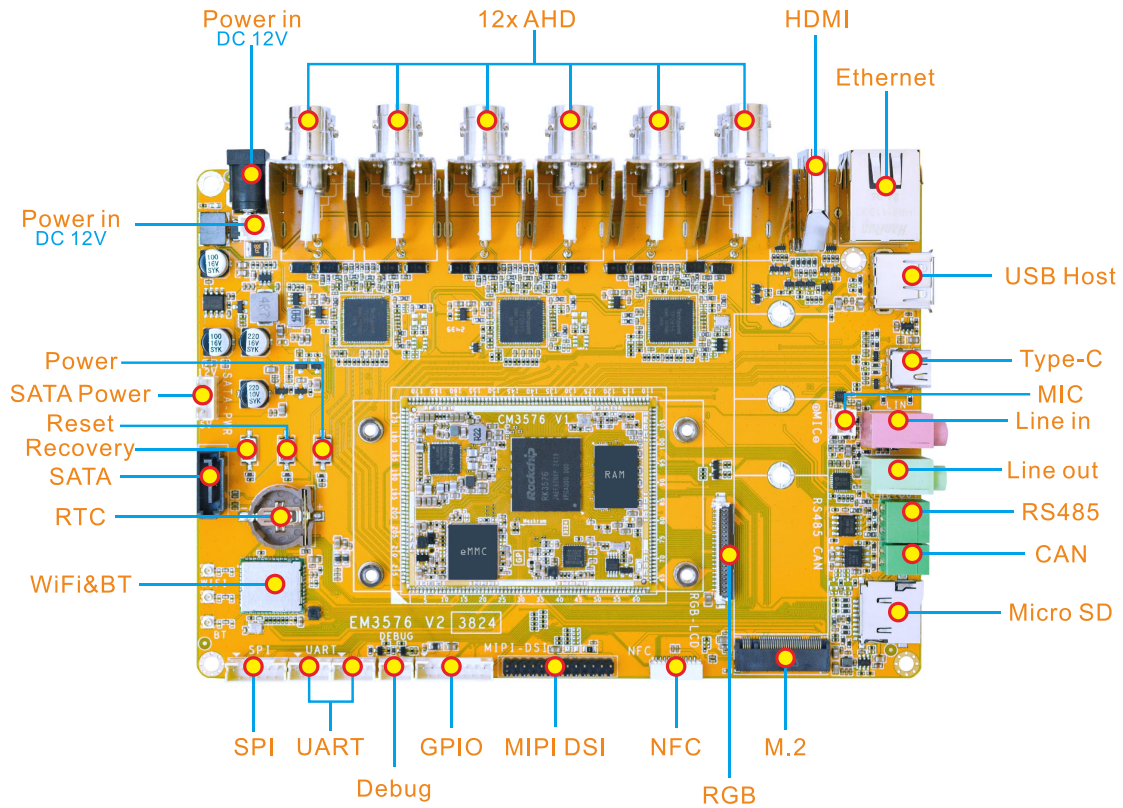

Specifications	
CPU	Rockchip RK3576 4x Cortex-A72 cores @ 2.2 GHz and 4x Cortex-A53 cores @ 1.8 GHz
Memory	4GB/ 8GB.
Storage	32GB/ 64GB/ 128GB eMMC M.2 PCIe 2.0 socket NVMe SSD (Expand with 2242 NVMe SSD) MicroSD card slot (Expand with TF card) SATA3.1 socket*
Power Supply	12V/3A DC input jack
USB	1x USB3.2 Type-C 1x USB2.0 Host*
Connectivity	Gigabit Ethernet RJ45 ports via Realtek RTL8211F-CG controller 2.4G/5G 2T2R WiFi (802.11a/b/g/n/ac) with Bluetooth 4.1
Serial	1x Serial port for debug, 3-pin connector 2x UART, 4-pin connectors 1x RS485 3-pin connector
Display	HDMI2.1, up to 4Kp120 MIPI LVDS, default 1080p60 up to 2Kp60 eDP 1.4, 2560x1600@60Hz



Audio	2x 3.5mm audio jack for Line in/Line out. ES8388 audio codec 1x MIC, 2-pin connector 8-channel audio via HDMI
Camera	12x AHD Camera, BNC connector
Keys & Switch	Reset, Recovery, Power
Other features	RTC with battery connector; GPIO; SPI
Dimension	Based board – 170 x 120 mm; CPU module – 57.5 x 44.0 mm

** SATA and USB2.0 Host cannot be used simultaneously*

1.4 PCB Dimension

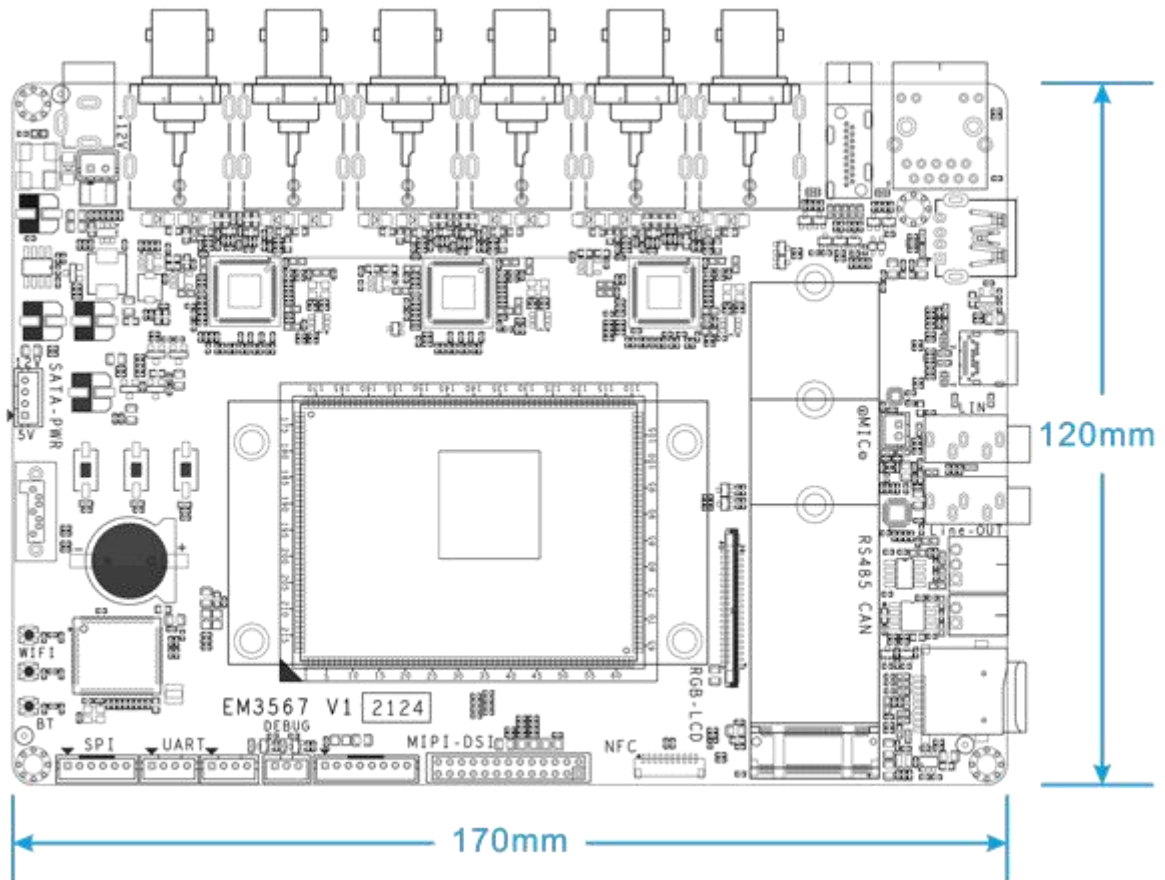

1.5 Block Diagram

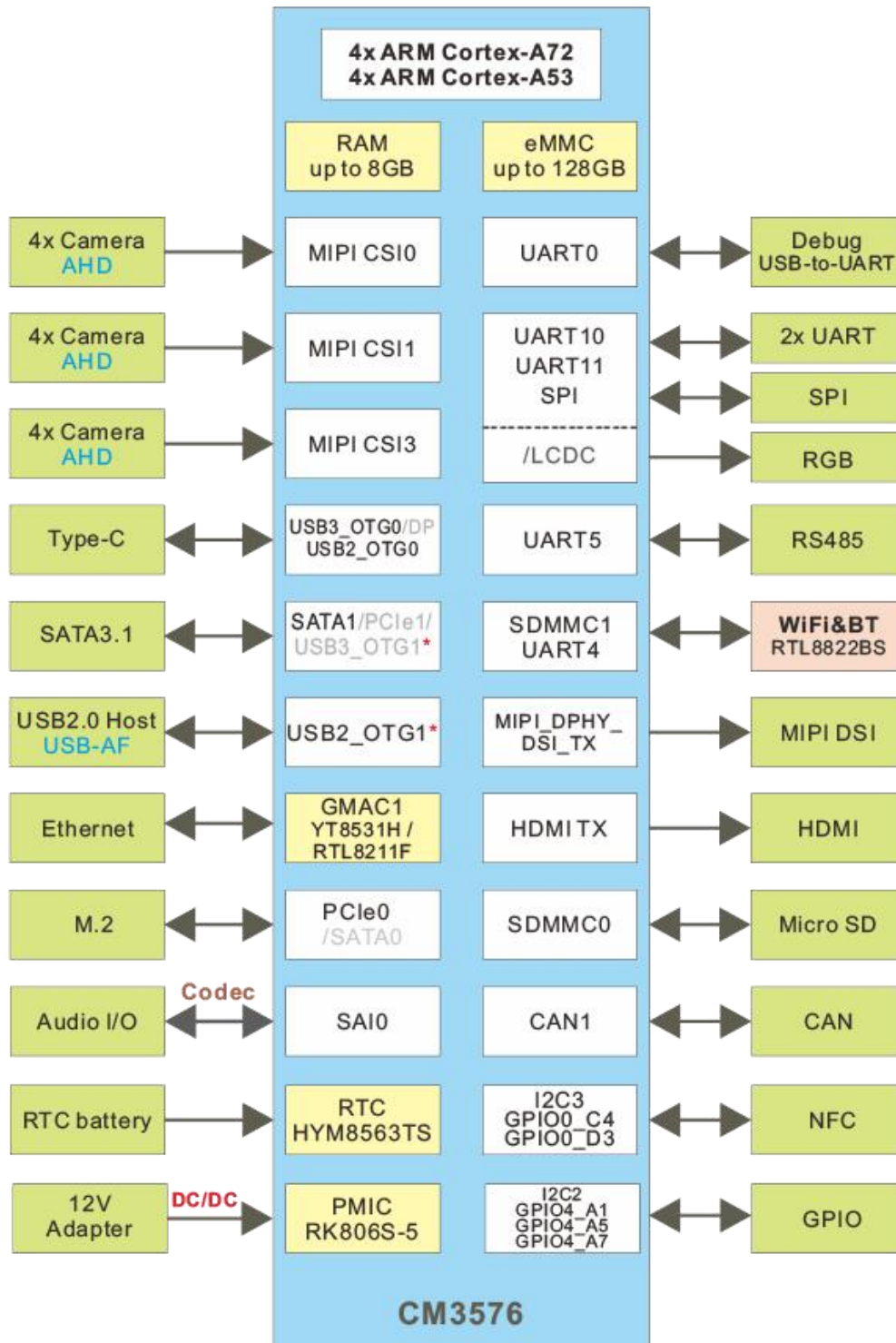

* SATA and USB2.0 Host cannot be used simultaneously.
USB2.0 port is disabled also when USB3 is disabled.

1.6 CPU module Introduction

CM3576 specifications

Pin number – 218 pins, 0.9mm pitch

Dimension – 57.5 x 44.0mm

Layer – 8 Layers, complying with EMS/EMI

Power supply – DC 3.3-5.5V

Application – Industrial HMI, Motion Control and Robotics, Multi-Camera Monitoring, DMS&OMS, Automatic Vehicle Identification, Home Security and Surveillance, etc.

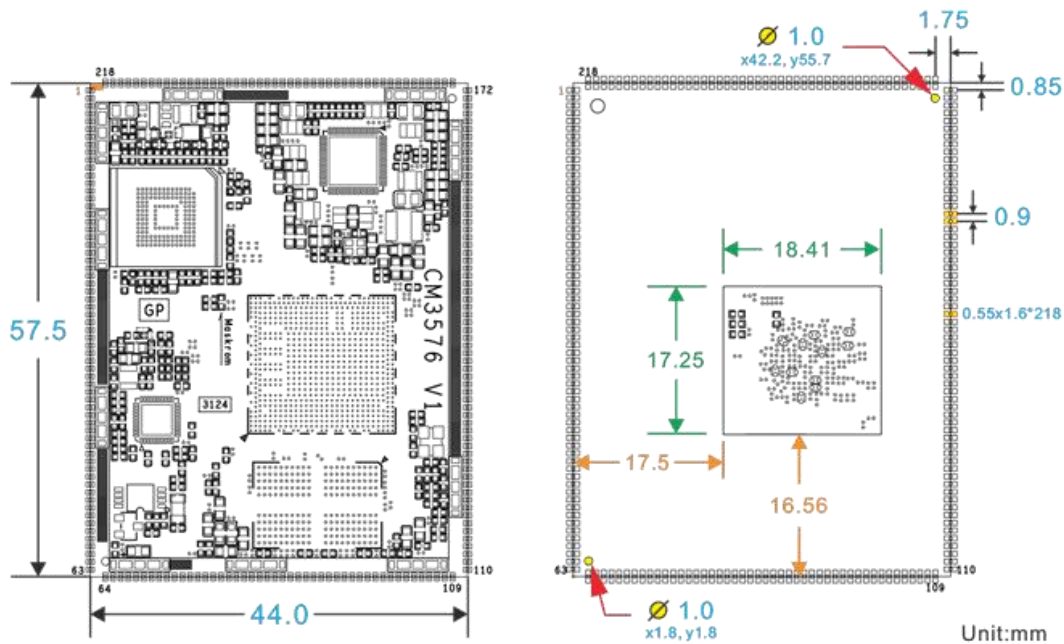

Pin Definition

Pin	Signal	Description or functions	GPIO serial	IO Voltage
1	VCC_SYS	System Power Input		3.4V-5.5V
2	VCC_SYS	System Power Input		3.4V-5.5V
3	VCC_SYS	System Power Input		3.4V-5.5V
4	PWRON_L	Power Key input		3.4V-5.5V
5	VCC_3V3_S3	3.3V GPIO Power output	Max 500mA	3.3V
6	UART0_TX_M0	For debug default	GPIO0_D4_u	3.3V
7	UART0_RX_M0	For debug default	GPIO0_D5_u	3.3V
8	GND	Ground		0V
9	RESET_L	GPIO0_A1_z connected(PU)		1.8V
10	SDMMC0_DET_L_1V 8	(PU100K)	GPIO0_A7_u	1.8V

11	WIFI_WAKE_HOST_H_1V8	I2C0_SCL_M0	GPIO0_B0_z	1.8V
12	BT_WAKE_HOST_H_1V8	I2C0_SDA_M0	GPIO0_B1_z	1.8V
13	HOST_WAKE_BT_H_1V8	SPDIF_TX1_M2/SPI2_CLK_M1/PDM0_CLK1_M2/CLK1_32K_OUT/SATA_MPSWIT	GPIO1_D5_d	1.8V
14	SAI2_SCLK_M0_1V8	I3C0_SDA_PU_M1/UART10_RX_M1	GPIO1_D1_d	1.8V
15	SAI2_SDO_M0_1V8	UART10_TX_M1	GPIO1_D0_d	1.8V
16	SAI2_SDI_M0_1V8	I3C0_SDA_M1/PWM1_CH4_M1	GPIO1_D3_d	1.8V
17	SAI2_LRCK_M0_1V8	I3C0_SCL_M1/PWM1_CH3_M1	GPIO1_D2_d	1.8V
18	WIFI_REG_ON_H_1V8	I2C8_SCL_M1/UART2_TX_M0/PDM0_SDI0_M2/SATA_CPPOD	GPIO1_C6_d	1.8V
19	BT_REG_ON_H_1V8	I2C8_SDA_M1/UART2_RX_M0/PDM0_SDI1_M2/SATA_CPDET	GPIO1_C7_d	1.8V
20	UART4_CTSN_M1_1V8	SDMMC1_DET_M0/I2C6_SDA_M1/SPI2_CSN0_M1	GPIO1_C3_u	1.8V
21	UART4_RTSN_M1_1V8	SDMMC1_PWEN_M0/I2C6_SCL_M1/SPI2_CSN1_M1/PWM1_CH2_M1	GPIO1_C2_u	1.8V
22	UART4_TX_M1_1V8	SPI2_MOSI_M1/UART2_RTS_M0/PCIE0_BUTTONRT	GPIO1_C4_d	1.8V
23	UART4_RX_M1_1V8	SPI2_MISO_M1/UART2_CTS_M0/PCIE1_BUTTONRT	GPIO1_C5_d	1.8V
24	SDMMC1_D1_M0_1V8	I2C9_SCL_M1/SPI1_MOSI_M0/PCIE1_WAKE_M1/SAI3_LRCK_M1/PWM1_CH1_M1	GPIO1_B5_d	1.8V
25	SDMMC1_D0_M0_1V8	I2C9_SDA_M1/SPI1_CLK_M0/PCIE1_CLKREQ_M1/SAI3_SCLK_M1/PWM1_CH0_M1	GPIO1_B4_d	1.8V
26	SDMMC1_D2_M0_1V8	UART3_CTS_M2/SPI1_MISO_M0/PCIE0_CLKREQ_M1/SAI3_SDO_M1	GPIO1_B6_d	1.8V

27	SDMMC1_D3_M0_1V8	UART3_RTS_M2/SPI1_CS N0_M0/PCIE0_WAKE_M1/ SAI3_SDI_M1	GPIO1_B7_d	1.8V
28	SDMMC1_CMD_M0_1V8	UART3_TX_M2/SPI1_CSN 1_M0/PDM0_SDI2_M2/PW M0_CH0_M1	GPIO1_C0_d	1.8V
29	SDMMC1_CLK_M0_1V8	UART3_RX_M2/PDM0_CL K0_M2/SAI3_MCLK_M1	GPIO1_C1_d	1.8V
30	GND	Ground		0V
31	RECOVERY_SARADC_VIN1	RECOVERY MODE/ADC_IN1(PU10K)		1.8V
32	SARADC_VIN2	ADC_IN2		1.8V
33	GND	Ground		0V
34	SDMMC0_CLK	I3C1_SDA_PU_M1/I2C5_S CL_M0/UART5_TX_M2/SPI 0_CLK_M1/SAI3_SCLK_M 3	GPIO2_A5_d/ FSPI1_CLK_M0	3.3V
35	SDMMC0_D1	DSM_ALN_M0/I2C8_SDA_ M0/UART0_TX_M1/UART7 _TX_M2/SPI0_MISO_M1/C AN0_TX_M0/SAI3_MCLK_ M3	GPIO2_A1_d/ PWM2_CH3_M0/ FSPI1_D1_M0	3.3V
36	SDMMC0_D0	DSM_ALP_M0/I2C8_SCL_ M0/UART0_RX_M1/UART7 _RX_M2/SPI0_MOSI_M1/C AN0_RX_M0	GPIO2_A0_d/ PWM2_CH2_M0/ FSPI1_D0_M0	3.3V
37	SDMMC0_CMD	I2C5_SDA_M0/UART5_RX _M2/SPI0_CSN0_M1/SAI3 _SDO_M3	GPIO2_A4_d/ PWM2_CH4_M0/ FSPI1_CSN0_M0	3.3V
38	SDMMC0_D3	I3C1_SDA_M1/DSM_ARN_ M0/UART5_CTSN_M2/SAI 3_SDI_M3/CAN1_TX_M0	GPIO2_A3_d/ FSPI1_D3_M0/ JTAG_TMS_M0	3.3V
39	SDMMC0_D2	I3C1_SCL_M1/DSM_ARN_ M0/UART5_RTSN_M2/SAI 3_LRCK_M3/CAN1_RX_M 0	GPIO2_A2_d/ FSPI1_D2_M0/ JTAG_TCK_M0	3.3V
40	LCDC_DEN/EBC_SDL E/DSCM_DATA0	I2C3_SCL_M2/UART5_RX _M0/SPI3_CLK_M1/SAI1_ SDI1_M1/FLEXBUS1_D1	GPIO3_D4_d	3.3V
41	LCDC_VSYNC/EBC_ SDCLK/DSCM_CLKN	UART5_CTS_M0/SPI3_MO SI_M1/SAI1_SDI3_M1/FLE XBUS1_CLK/PWM2_CH6_ M3	GPIO3_D6_d	3.3V



42	LCDC_HSYNC/EBC_GDCLK/DSMC_CLKP	I2C3_SDA_M2/UART5_TX_M0/SPI3_MISO_M1/SAI1_SDI2_M1/FLEXBUS1_D0	GPIO3_D5_d	3.3V
43	LCDC_CLK/EBC_SDOE/DSMC_RESETN	UART5_RTS_M0/SPI3_CS_N1_M1/SAI4_SCLK_M1/FLEXBUS1_D12_M0/FLEXBUS0_D15_M0/FLEXBUS1_CSn_M1/CAM_CLK0_OUT_M0	GPIO3_D7_d/ PWM2_CH7_M3	3.3V
44	DSMC_INT0/GPIO4_A0_d	I2C7_SCL_M2/UART3_TX_M0/SPI1_CSN1_M2/SAI4_LRCK_M1/FLEXBUS1_D14_M0/FLEXBUS0_D13_M0/FLEXBUS1_CSn_M3/CAM_CLK1_OUT_M0	GPIO4_A0_d/ MIPI_TE_M2/ SPDIF_RX0_M1	3.3V
45	DSMC_INT2/GPIO4_A1_d	I2C7_SDA_M2/UART3_RX_M0/SAI4_SDO_M1/FLEXBUS1_D13_M0/FLEXBUS0_D14_M0/FLEXBUS0_CSn_M1/CAM_CLK2_OUT_M0	GPIO4_A1_d/ VO_POST_EMPTY/ SPDIF_TX0_M1	3.3V
46	PHY1_LED1/CFG_LED00	Speed LED(PD4.7K)		3.3V
47	PHY1_LED2/CFG_LED01	Link LED(PU4.7K)		3.3V
48	PHY1_MDI0+			0.5V
49	PHY1_MDI0-			0.5V
50	PHY1_MDI1+			0.5V
51	PHY1_MDI1-			0.5V
52	PHY1_MDI2+			0.5V
53	PHY1_MDI2-			0.5V
54	PHY1_MDI3+			0.5V
55	PHY1_MDI3-			0.5V
56	32KOUT_RTC_1V8	RTC_CLK 32.768KHz output	GPIO0_A2_d(Note1)	1.8V
57	VCC_RTC	RTC Power input		1.8~3.3V
58	LCDC_D0/EBC_SDD00/DSMC_CSN0	I3C1_SCL_M2/UART2_CTS_M2/SAI2_SDO_M2/FLEXBUS1_D2	GPIO3_D3_d/ PWM2_CH5_M3	3.3V
59	LCDC_D1/EBC_SDD01/DSMC_CSN3	I3C1_SDA_M2/UART2_RTS_M2/SPI4_CSN1_M1/SAI2_SDI_M2/FLEXBUS0_D12/FLEXBUS0_CS_M3/FLEXBUS1_D15_M0	GPIO3_D2_d/ PWM2_CH4_M3	3.3V

60	LCDC_D2/EBC_SDD O2/DSMC_CSN2	I3C1_SDA_PU_M2/SPI4_C LK_M1/SAI2_MCLK_M2/FL EXBUS0_D11/FLEXBUS1_ CS_M2	GPIO3_D1_d	3.3V
61	LCDC_D3/EBC_SDD O3/DSMC_DATA1	UART8_CTS_M0/SPI1_CS N0_M2/SAI1_MCLK_M1/FL EXBUS1_D3	GPIO3_D0_d/ PWM2_CH3_M3	3.3V
62	LCDC_D4/EBC_SDD O4/DSMC_DATA2	UART8_RTS_M0/SPI1_CL K_M2/SAI1_SCLK_M1/FLE XBUS1_D4	GPIO3_C7_d	3.3V
63	LCDC_D5/EBC_SDD O5/DSMC_DATA3	UART8_TX_M0/SPI1_MOS I_M2/SAI1_LRCK_M1/FLE XBUS1_D5	GPIO3_C6_d	3.3V
64	LCDC_D6/EBC_SDD O6/DSMC_DATA4	UART8_RX_M0/SPI1_MIS O_M2/SAI1_SDO0_M1/FL EXBUS1_D6	GPIO3_C5_d/ PWM2_CH2_M3	3.3V
65	LCDC_D7/EBC_SDD O7/DSMC_DATA5	I2C5_SCL_M3/UART11_TX _M0/SPI2_CSN0_M2/SAI1 _SDO0_M1/FLEXBUS1_D 7/CAN0_TX_M3	GPIO3_C4_d	3.3V
66	LCDC_D8/EBC_SDD O8/DSMC_INT3	I2C9_SDA_M3/UART11_C TS_M0/SPI4_MOSI_M1/SA I2_LRCK_M2/FLEXBUS0_ D10/FLEXBUS0_CSN_M2	GPIO3_C3_d/ PWM2_CH1_M3	3.3V
67	LCDC_D9/EBC_SDD O9/DSMC_INT1	I2C9_SCL_M3/UART11_R TS_M0/SPI4_MISO_M1/SA I2_SCLK_M2/FLEXBUS0_ D9	GPIO3_C2_d/ PWM2_CH0_M3	3.3V
68	LCDC_D10/EBC_SD DO10/DSMC_DATA6	I2C5_SCL_M3/UART11_R X_M0/SPI2_MISO_M2/SAI 1_SDO2_M1/FLEXBUS1_ D8/CAN0_RX_M3	GPIO3_C1_d	3.3V
69	LCDC_D11/EBC_SDD O11/DSMC_DATA7	I2C4_SCL_M3/UART2_TX _M2/UART3_RTS_M1/SAI1 _SDO3_M1/FLEXBUS1_D 9	GPIO3_C0_d	3.3V
70	LCDC_D12/EBC_SD DO12/DSMC_DQS0	I2C4_SDA_M3/UART2_RX _M2/UART3_CTS_M1/SAI1 _SDO0_M1/FLEXBUS1_D 10/FLEXBUS1_CSN_M0	GPIO3_B7_d	3.3V
71	LCDC_D13/EBC_SD DO13/DSMC_DQS1	SPI3_CSN0_M1/ETH0_TX CLK_M0/FLEXBUS0_CLK	GPIO3_B6_d/ PWM0_CH1_M3	3.3V

72	LCDC_D14/EBC_SD DO14/DSMC_DATA8	UART9_CTS_M1/ETH0_TX D0_M0/SPDIF_TX1_M0/FL EXBUS0_D0	GPIO3_B5_d/ PWM1_CH5_M3	3.3V
73	LCDC_D15/EBC_SD DO15/DSMC_DATA9	UART9_RTS_M1/ETH0_TX D1_M0/SPDIF_RX1_M0/FL EXBUS0_D1	GPIO3_B4_d/ PWM1_CH4_M3	3.3V
74	LCDC_D16/EBC_SD CE0/DSMC_DATA10	I2C8_SCL_M3/UART9_TX _M1/ETH0_TXCTL_M0/PD M1_SDI0_M2/FLEXBUS0_ D2	GPIO3_B3_d	3.3V
75	LCDC_D17/EBC_SD CE1/DSMC_DATA11	I2C8_SDA_M3/UART9_RX _M1/ETH0_RXD0_M0/PD M1_SDI1_M2/FLEXBUS0_ D3	GPIO3_B2_d	3.3V
76	LCDC_D18/EBC_SD CE2/DSMC_DATA12	UART10_TX_M0/SPI4_CS N0_M1/ETH0_RXD1_M0/P DM1_CLK0_M2/FLEXBUS 0_D4	GPIO3_B1_d/ PWM1_CH3_M3	3.3V
77	LCDC_D19/EBC_SD CE3/DSMC_CSN1	UART10_RX_M0/SPI2_MO SI_M2/ETH0_MCLK_M0/S AI4_MCLK_M1/FLEXBUS0_ _D8	GPIO3_B0_d/ PWM0_CH0_M3	3.3V
78	LCDC_D20/EBC_VC OM/DSMC_DATA13	UART10_RTS_M0/UART1_ TX_M2/ETH0_RXCTL_M0/ PDM1_CLK1_M2/FlexBUS 0_D5	GPIO3_A7_d	3.3V
79	LCDC_D21/EBC_GD OE/DSMC_DATA14	UART10_CTS_M0/UART1_ RX_M2/ETH0_MDC_M0/P DM1_SDI2_M2/FlexBUS0_ D6	GPIO3_A6_d/ PWM1_CH2_M3	3.3V
80	LCDC_D22/EBC_GD SP/DSMC_DATA15	SPI2_CSn1_M2/UART1_R TS_M2/ETH0_MDIO_M0/P DM1_SDI3_M2/FlexBUS0_ D7	GPIO3_A5_d/ PWM1_CH1_M3	3.3V
81	LCDC_D23/EBC_SD SHR/DSMC_RDYN	SPI2_CLK_M2/UART1_CT S_M2/ETH0_CLKOUT_25 M_M0/SAI4_SDI_M1/FlexB US1_D11/FlexBUS0_CSn_ M0	GPIO3_A4_d/ PWM1_CH0_M3	3.3V
82	TYPEC_DPTX_AUX_ PUPDCTL1	AUPLL_CLKIN_M2/SAI1/4 _MCLK_M0	GPIO4_A2_d /PWM2_CH5_M0	3.3V



83	PCIE1_CLKREQn_M2	I2C2_SDA_M2/UART5_CTS_M1/SPI4_CS1_M2/SAI1_LRCK_M0/FlexBUS1_D12_M1	GPIO4_A5_d	3.3V
84	PCIE1_PWREN_H	I2C2_SCL_M2/UART5_RTS_M1/SPI3_CS0_M2/SAI1_SCLK_M0/FlexBUS1_CS_M4	GPIO4_A3_d/ PWM2_CH4_M1	3.3V
85	HDMI_TX_ON_H	I2C4_SDA_M1/UART6_RX_M0/SPI3_MISO_M2/SAI4_LRCK_M0/PDM1_CLK0_M1/FlexBUS1_D14_M1/CAN0_RX_M2	GPIO4_A6_d	3.3V
86	TYPEC_DPTX_AUX_PUPDCTL2	I2C4_SCL_M1/UART6_TX_M0/SPI3_MOSI_M2/SAI4_SCLK_M0/PDM1_SDI3_M1/FlexBUS1_D13_M1/CAN0_TX_M2	GPIO4_A4_d	3.3V
87	HP_CTL_H	SPI3_CLK_M2/SAI4_SDI_M0/SAI1_SDO0_M0	GPIO4_A7_d/ PWM2_CH6_M0	3.3V
88	I2C3_SCL_M0_Sensor	PCIE0_CLKREQ_M2/IUART2_TX_M1/SPDIF_TX0_M0/FlexBUS0_D15_M1/CAN1_TX_M2	GPIO4_B5_d (PU2.2K)	3.3V
89	I2C3_SDA_M0_Sensor	PCIE0_WAKE_M2/IUART2_RX_M1/SPDIF_RX0_M0/FlexBUS0_CSN_M4/CAN1_RX_M2	GPIO4_B4_d (PU2.2K)	3.3V
90	SPK_CTL_H	SPI3_CS1_M2/SPI4_CS0_M2/PDM1_SDI0_M1/SAI1_SDI0_M0/SAI4_SDO_M0	GPIO4_B3_d/ PWM2_CH7_M0	3.3V
91	PCIE1_PERSTn	SPI4_MISO_M2/PDM1_SDI1_M1/SAI1_SDI1_M0/SAI1_SDO3_M0/FlexBUS1_D15_M1	GPIO4_B2_d/ MIPI_TE_M0	3.3V
92	IRC_BIN	UART2_CTS_M1/UART6_CTS_M0/UART5_RX_M1/SPI4_MOSI_M2/PDM1_SDI2_M1/SAI1_SDI2_M0/SAI1_SDO2_M0/FlexBUS1_D14_M1	GPIO4_B1_d	3.3V

93	IRC_AIN	UART2_RTS_M1/UART6_RTS_M0/UART5_TX_M1/SPI4_CLK_M2/PDM1_CLK1_M1/SAI1_SDI3_M0/SAI1_SDO1_M0/FlexBUS1_D13_M1	GPIO4_B1_d	3.3V
94	PCIE0_CLKREQn_M3	I2C6_SCL_M3/SPI4_MISO_M0/SAI4_SDI_M2/VP1_SYNC_OUT/CAN1_TX_M1	GPIO4_C6_d/ PWM2_CH2_M1/ SATA0_ACTLED_M1	3.3V
95	PCIE0_PERSTn	I2C6_SDA_M3/SPI4_CLK_M0/SAI4_SCLK_M2/VP2_SYNC_OUT/CAN1_RX_M1	GPIO4_C7_d/ PWM2_CH3_M1	3.3V
96	PWM2_CH5_M1_FAN	I2C3_SDA_M3/UART6_RX_M3/SPI4_MOSI_M0/SAI4_SDO_M2/VP0_SYNC_OUT/ISP_FLASH_TRIGOUT_M1	GPIO4_C5_d/ PWM2_CH5_M1/ SATA1_ACTLED_M1 PCIE0_WAKE_M3	3.3V
97	HDMI_TX_HPDIN_M0	I2C7_SDA_M3/UART11_RX_M2/EDP_HPD_M0/PCIE1_CLKREQ_M3/DSM_ALN_M1	GPIO4_C1_d/ PWM0_CH1_M1	3.3V
98	HDMI_TX_SDA	I2C2_SDA_M3/UART9_RX_M2/CAN0_RX_M1/DSM_ARN_M1	GPIO4_C3_d/ PWM2_CH1_M1	3.3V
99	HDMI_TX_SCL	I2C2_SCL_M3/UART9_TX_M2/CAN0_TX_M1/DSM_ARP_M1	GPIO4_C2_d/ PWM2_CH0_M1	3.3V
100	DP_HPDIN_M0	I2C3_SCL_M3/UART6_TX_M3/SPI4_CS _{n0} _M0/SAI4_LRCK_M2/ISP_PRLIGHT_TRIG_M1	GPIO4_C4_d/ PWM2_CH6_M1	3.3V
101	HDMI_TX_CEC_M0	I2C7_SCL_M3/UART11_TX_M2/SPI4_CS _{n1} _M0/SAI_MCLK_M2/DSM_ALP_M1	GPIO4_C0_d/ PWM1_CH5_M1/ PCIE1_WAKE_M3	3.3V
102	GND	Ground		0V
103	MIPI_DPHY_CSI0_PWREN_H_1V8	UART3_RTS_M0/SPI3_CS _{n0} _M0/SAI3_SDI_M2/ETH0_RXD1_M1/CAN_RX_M3	GPIO3_A3_d/ VI_CIF_CLKI/ SPDIF_TX1_M1	1.8V
104	SAI0_SDI0_M0_1V8	UART1_TX_M1/PDM0_SDI3_M3/ETH0_TXD1_M1	GPIO2_B0_d/ VI_CIF_D13	1.8V
105	SAI0_SDI1_M0_1V8	UART1_RX_M1/PDM0_SDI2_M3/ETH0_TXD0_M1	GPIO2_B1_d/ VI_CIF_D12	1.8V

106	SAI0_SDI2_M0_1V8	UART1_CTS_M1/SPI4_CS n0_M3/PDM0_SDI1_M3/P CIE0_CLKREQ_M0	GPIO2_B2_d/ VI_CIF_D11	1.8V
107	SAI0_SDI3_M0_1V8	UART7_CTS_M1/SPI4_MO SI_M3/PDM0_SDI0_M3/SA TA0_ACTLED_M0	GPIO2_B4_d/ VI_CIF_D9	1.8V
108	SAI0_SCLK_M0_1V8	I2C8_SCL_M2/UART8_CT S_M1/UART7_RX_M0	GPIO2_B6_d	1.8V
109	SAI0_LRCK_M0_1V8	I2C8_SDA_M2/UART8_RT S_M1/UART7_TX_M0	GPIO2_B7_d	1.8V
110	SAI0_MCLK_M0_1V8	UART7_RTS_M0/SPI4_MI SO_M3/PDM0_CLK0_M3/S ATA1_ACTLED_M0	GPIO2_B5_d/ VI_CIF_D8	1.8V
111	SAI0_SDO0_M0_1V8	I2C4_SCL_M2/UART8_TX _M1/SPI4_CS _n 1_M3/ETH0 _RXD0_M1	GPIO2_A6_d/ VI_CIF_D15	1.8V
112	SAI0_SDO1_M0_1V8	I2C4_SDA_M2/UART8_RX _M1/ETH0_TXCTL_M1	GPIO2_A7_d/ VI_CIF_D14	1.8V
113	SAI0_SDO2_M0_1V8	UART1_RTS_M1/SPI4_CL K_M3/PDM0_CLK1_M3/PC IE1_CLKREQ_M0	GPIO2_B3_d/ VI_CIF_D10	1.8V
114	SPDIF_RX1_M1_1V8	UART3_RTS_M0/SPI3_MI SO_M0/SAI3_SDO_M2/ET H0_RXCTL_M1/CAN_TX_ M3	GPIO3_A2_d/ VI_CIF_CLKO/ MIPI_TE_M1	1.8V
115	I2C7_SDA_M1_1V8	UART3_RX_M0/SPI3_MOS I_M0/SAI3_LRCK_M2/ETH 0_MDC_M1(PU2.2K)	GPIO3_A1_d/ VI_CIF_VSYNC	1.8V
116	I2C7_SCL_M1_1V8	UART3_TX_M0/SPI3_CLK _M0/SAI3_SCLK_M2/ETH0 _MDIO_M1(PU2.2K)	GPIO3_A0_d/ VI_CIF_HREF	1.8V
117	GND	Ground		0V
118	DP_TX_AUXP			0.5V
119	DP_TX_AUXN			0.5V
120	USB2_OTG1_DP			0.5V
121	USB2_OTG1_DM			0.5V
122	USB2_OTG0_DP			0.5V
123	USB2_OTG0_DM			0.5V
124	USB3_OTG0_SSRX1 N/DP_TX_D0N			0.5V
125	USB3_OTG0_SSRX1 P/DP_TX_D0P			0.5V
126	USB3_OTG0_SSTX1 P/DP_TX_D1P			0.5V



127	USB3_OTG0_SSTX1 N/DP_TX_D1N			0.5V
128	USB3_OTG0_SSRX2 N/DP_TX_D2N			0.5V
129	USB3_OTG0_SSRX2 P/DP_TX_D2P			0.5V
130	USB3_OTG0_SSTX2 P/DP_TX_D3P			0.5V
131	USB3_OTG0_SSTX2 N/DP_TX_D3N			0.5V
132	GND	Ground		0V
133	MIPI_DPHY_DSI_TX_ D0N	MIPI_CPHY_DSI_TX_TRIO 0A		0.5V
134	MIPI_DPHY_DSI_TX_ D0P	MIPI_CPHY_DSI_TX_TRIO 0B		0.5V
135	MIPI_DPHY_DSI_TX_ D1N	MIPI_CPHY_DSI_TX_TRIO 0C		0.5V
136	MIPI_DPHY_DSI_TX_ D1P	MIPI_CPHY_DSI_TX_TRIO 1A		0.5V
137	MIPI_DPHY_DSI_TX_ CLKN	MIPI_CPHY_DSI_TX_TRIO 1B		0.5V
138	MIPI_DPHY_DSI_TX_ CLKP	MIPI_CPHY_DSI_TX_TRIO 1C		0.5V
139	MIPI_DPHY_DSI_TX_ D2N	MIPI_CPHY_DSI_TX_TRIO 2A		0.5V
140	MIPI_DPHY_DSI_TX_ D2P	MIPI_CPHY_DSI_TX_TRIO 2B		0.5V
141	MIPI_DPHY_DSI_TX_ D3N	MIPI_CPHY_DSI_TX_TRIO 2C		0.5V
142	MIPI_DPHY_DSI_TX_ D3P			0.5V
143	MIPI_DPHY_CSI0_R X_D0P	MIPI_CPHY_CSI_TX_TRIO 0B		0.5V
144	MIPI_DPHY_CSI0_R X_D0N	MIPI_CPHY_CSI_TX_TRIO 0A		0.5V
145	MIPI_DPHY_CSI0_R X_D1P	MIPI_CPHY_CSI_TX_TRIO 1A		0.5V
146	MIPI_DPHY_CSI0_R X_D1N	MIPI_CPHY_CSI_TX_TRIO 0C		0.5V
147	MIPI_DPHY_CSI0_R X_CLKP	MIPI_CPHY_CSI_TX_TRIO 1C		0.5V
148	MIPI_DPHY_CSI0_R X_CLKN	MIPI_CPHY_CSI_TX_TRIO 1B		0.5V

149	MIPI_DPHY_CSI0_R X_D2P	MIPI_CPHY_CSI_TX_TRIO 2B		0.5V
150	MIPI_DPHY_CSI0_R X_D2N	MIPI_CPHY_CSI_TX_TRIO 2A		0.5V
151	MIPI_DPHY_CSI0_R X_D3P			0.5V
152	MIPI_DPHY_CSI0_R X_D3N	MIPI_CPHY_CSI_TX_TRIO 2C		0.5V
153	GND	Ground		0V
154	HDMI_TX_D3N	EDP_TX3N		0.5V
155	HDMI_TX_D3P	EDP_TX3P		0.5V
156	HDMI_TX_D0P	EDP_TX0P		0.5V
157	HDMI_TX_D0N	EDP_TX0N		0.5V
158	HDMI_TX_D1P	EDP_TX1P		0.5V
159	HDMI_TX_D1N	EDP_TX1N		0.5V
160	HDMI_TX_D2P	EDP_TX2P		0.5V
161	HDMI_TX_D2N	EDP_TX2N		0.5V
162	HDMI_TX_SBDN	EDP_AUXN		0.5V
163	HDMI_TX_SBDP	EDP_AUXP		0.5V
164	GND	Ground		0V
165	MIPI_DPHY_CSI2_R X_CLKP			0.5V
166	MIPI_DPHY_CSI2_R X_CLKN			0.5V
167	MIPI_DPHY_CSI1_R X_CLKN			0.5V
168	MIPI_DPHY_CSI1_R X_CLKP			0.5V
169	MIPI_DPHY_CSI1_R X_D3N	MIPI_DPHY_CSI2_RX_D1 N		0.5V
170	MIPI_DPHY_CSI1_R X_D3P	MIPI_DPHY_CSI2_RX_D1 P		0.5V
171	MIPI_DPHY_CSI1_R X_D2N	MIPI_DPHY_CSI2_RX_D0 N		0.5V
172	MIPI_DPHY_CSI1_R X_D2P	MIPI_DPHY_CSI2_RX_D0 P		0.5V
173	MIPI_DPHY_CSI1_R X_D1N			0.5V
174	MIPI_DPHY_CSI1_R X_D1P			0.5V
175	MIPI_DPHY_CSI1_R X_D0N			0.5V



176	MIPI_DPHY_CSI1_RX_D0P			0.5V
177	VCC_1V8_S3	1.8V GPIO Power output	Max 500mA	1.8V
178	USB2_OTG1_VBUSDET	USB2 VBUS Input		3.3V
179	TP_INT_L	I3C0_SDA_PU_M0/UART10_RX_M2/SAI0_SDO0_M1/DP_HPD_M1	GPIO0_C5_d	3.3V
180	LCD_BL_PWM1_CH1_M0	I2C1_SDA_M1/UART4_RX_M2/REFCLK2_OUT	GPIO0_B5_d/PWM1_CH1_M0	3.3V
181	PCIE1_WAKEn_M0	I2C4_SDA_M0/UART1_RTS_M0/PDM0_SDI3_M0/SAI0_SDO1/SDI3_M1	GPIO0_D3_d/PWM2_CH0_M0	3.3V
182	GPIO0_B4_d	I2C1_SCL_M1/UART4_TX_M2/REFCLK1_OUT	PWM1_CH0_M0	3.3V
183	USBCC_INT_L	SPI0_MISO_M0/PDM0_SDI1_M0/SAI0_SDO3/SDI1_M1	GPIO0_D1_d	3.3V
184	PCIE0_PWREN_H	I2C3_SDA_M1/SPI0_CLK_M0/SAI0_LRCK_M1	GPIO0_C7_d	3.3V
185	PCIE0_WAKEn_M0	I2C4_SCL_M0/UART1_CTS_M0/PDM0_SDI2_M0/SAI0_SDO2/SDI2_M1	GPIO0_D2_d/PWM1_CH5_M0	3.3V
186	LCD_PWREN_H	I2C3_SCL_M1/SPI0_CS0_M0/SAI0_SCLK_M1	GPIO0_C6_d	3.3V
187	I2C2_SCL_M0_CC_RTC	UART1_TX_M0/PWM1_CH4_M0(PU2.2K)	GPIO0_B7_d	3.3V
188	I2C2_SDA_M0_CC_RTC	UART1_RX_M0/PWM1_CH3_M0(PU2.2K)	GPIO0_C0_d	3.3V
189	GPIO0_C4_d	UART10_TX_M2/PDM0_CLK0_M0/SAI0_MCLK_M1	PWM0_CH0_M0	3.3V
190	I2C0_SCL_M1_TP	I3C0_SCL_M0/UART8_TX_M2(PU2.2K)	GPIO0_C1_d	3.3V
191	I2C0_SDA_M1_TP	I3C0_SDA_M0/UART8_RX_M2(PU2.2K)	GPIO0_C2_d	3.3V
192	TP_RST_L	SPI0_MOSI_M0/PDM0_SDI0_M0/SAI0_SDI0_M1	GPIO0_D0_d	3.3V
193	GND	Ground		0V
194	PCIE0_RXP	SATA0_RXP		0.5V
195	PCIE0_RXN	SATA0_RXN		0.5V
196	PCIE0_TXN	SATA0_TXN		0.5V
197	PCIE0_TXP	SATA0_TXP		0.5V
198	PCIE0_REFCLKP			0.5V



199	PCIE0_REFCLKN			0.5V
200	PCIE1_TXP	SATA1_TXP/USB3_OTG1_SSTXP		0.5V
201	PCIE1_TXN	SATA1_TXN/USB3_OTG1_SSTXN		0.5V
202	PCIE1_RXP	SATA1_RXP/USB3_OTG1_SSRXP		0.5V
203	PCIE1_RXN	SATA1_RXN/USB3_OTG1_SSRXN		0.5V
204	PCIE1_REFCLKP			0.5V
205	PCIE1_REFCLKN			0.5V
206	GND	Ground		0V
207	MIPI_DPHY_CSI4_RX_CLKP			0.5V
208	MIPI_DPHY_CSI4_RX_CLKN			0.5V
209	MIPI_DPHY_CSI3_RX_D3N	MIPI_DPHY_CSI4_RX_D1N		0.5V
210	MIPI_DPHY_CSI3_RX_D3P	MIPI_DPHY_CSI4_RX_D1P		0.5V
211	MIPI_DPHY_CSI3_RX_D2N	MIPI_DPHY_CSI4_RX_D0N		0.5V
212	MIPI_DPHY_CSI3_RX_D2P	MIPI_DPHY_CSI4_RX_D0P		0.5V
213	MIPI_DPHY_CSI3_RX_CLKN			0.5V
214	MIPI_DPHY_CSI3_RX_CLKP			0.5V
215	MIPI_DPHY_CSI3_RX_D1N			0.5V
216	MIPI_DPHY_CSI3_RX_D1P			0.5V
217	MIPI_DPHY_CSI3_RX_D0N			0.5V
218	MIPI_DPHY_CSI3_RX_D0P			0.5V

Note:

1. Can change to GPIO, if RTC IC no needed.

2 Peripherals Introduction

2.1 Power (P1)

The DC JACK is 5.5 x 2.1mm, 3-pin plug Type. Typical 12V/3A DC adapter.



Pin	Signal	Description	Pin	Signal	Description
1	DC12V-IN	Main power supply. DC 12V power in	2	GND	Ground
3	GND	Ground			

2.2 Audio I/O

Audio I/O (J23, J22)

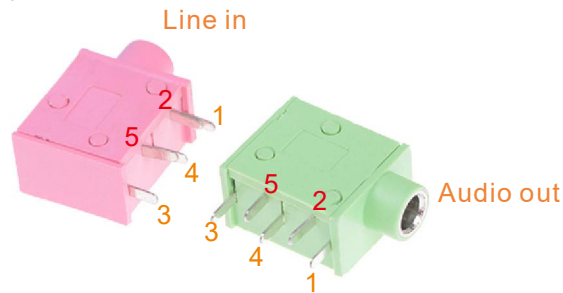

The EM3576 adopts audio code ES8388, provides stereo audio output (Green, 3.5mm audio jack) and line in (Pink, 3.5mm audio jack).

Feature

- Low power
- Integrated ADC and DAC
- IIS transfer audio data
- Stereo output, support recording

Line in (J22)					
Pin	Signal	Description	Pin	Signal	Description
1	AGND	Ground	2	RIN2	Right Channel input
3	RIN2	Right Channel input	4	LIN2	Left Channel input
5	LIN2	Left Channel input			
Audio out (J23)					
Pin	Signal	Description	Pin	Signal	Description

1	AGND	Ground	2	AUD_LI NEOUT _R	Right Channel Headphone Output
3	AUD_LI NEOUT _R	Right Channel Headphone Output	4	AUD_LI NEOUT _L	Left Channel Headphone Output
5	AUD_LI NEOUT _L	Left Channel Headphone Output			

MIC (CON6)

The CON6 is use to connect MIC model. Such as WM_64BC MIC/F6/DIP. It is used for recording.

MIC					
Pin	Signal	Description	Pin	Signal	Description
1	MIC_INP_PHON E	Command signal	2	MIC_INN_PHONE	Ground

Note:

1. The audio default output from **HDMI**. No sound in **headphone** if not remove HDMI.
2. Default recording via **MIC** if the **Line_in** jack is not plugged in.

2.3 HDMI OUT (J21)

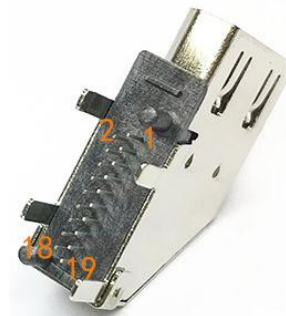
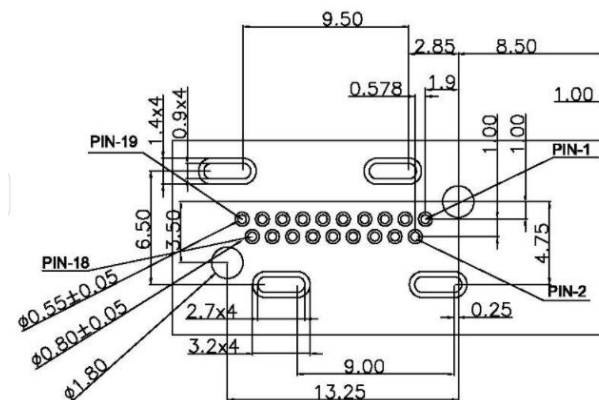

EM3576 supports HDMI 2.1 transmitter.

- Maximum bandwidth increased from 18 Gbps to 48 Gbps.
- Dynamic HDR technology.
- Game optimization, support: VRR, ALLM, QFT.
- Up to 4kx2k at 120Hz HDMI 2.1 display resolutions.
- Sound enhancement, support eARC.

Pin	Signal	Description	Pin	Signal	Description
1	HDMI_TX_D2P	HDMI data 2 pair	2	GND	Ground
3	HDMI_TX_D2N		4	HDMI_TX_D1P	HDMI data 1 pair

5	GND	Ground	6	HDMI_TX_D1N	
7	HDMI_TX_D0P	HDMI data 0 pair	8	GND	Ground
9	HDMI_TX_D0N		10	HDMI_TX_D3P	HDMI data 3 pair
11	GND	Ground	12	HDMI_TX_D3N	
13	HDMI_TX_CEC_P ORT	Consumer electronics control	14	HDMITX_SBDP	Utility
15	HDMI_TX_SCL_P ORT	HDMI I2C serial clock for DDC	16	HDMI_TX_SDA_P ORT	HDMI I2C serial data for DDC
17	GND	Ground	18	VCC5V_HDMI_TX	5V power supply
19	HDMITX_HPDIN/H DMITX_SBDN	Hot Plug Detect			

2.4 USB Type-C (J51)



EM3576 OTG is a USB Type-C port, it is used to download image and transfer between USB and DP display (multiplexed with DP TX), and supports ADB mode.

Feature

- Reversible plug design.
- Support USB 3.1/3.2 standard, the maximum transfer rate is up to 10Gbps (USB 3.1 Gen 2) or 20Gbps (USB4).
- Support DisplayPort Alt mode to output 4K@60Hz or 8K video signal.
- Support transmission of high-definition audio signals.
- Multifunctional expansion, support OTG function, can be connected to USB flash drive, card reader, mouse keyboard, etc; network connection; docking application: support multi-interface expansion (such as HDMI, USB-A, etc.).

Pin	Signal	Description	Pin	Signal	Description
A1	GND	Ground	A2	TYPEC_TX1P	Transmitter serial data +
A3	TYPEC_TX1N	Transmitter serial data -	A4	VBUS5V0_TYPEC	5V power supply
A5	TYPEC_CC1	Configuration channel	A6	TYPEC_DP	USB data DP
A7	TYPEC_DM	USB data DM	A8	TYPEC_SBU1	Sideband use (SBU)
A9	VBUS5V0_TYPE	5V power supply	A1	TYPEC_RX2N	Receiver serial

	C			0		data -
A1 1	TYPEC_RX2P	Receiver serial data +		A1 2	GND	Ground
B1	GND	Ground		B2	TYPEC_TX2P	Transmitter serial data +
B3	TYPEC_TX2N	Transmitter serial data -		B4	VBUS5V0_TYPEC	5V power supply
B5	TYPEC_CC2	Configuration channel		B6	TYPEC_DP	USB data DP
B7	TYPEC_DM	USB data DM		B8	TYPEC_SBU2	Sideband use (SBU)
B9	VBUS5V0_TYPEC	5V power supply		B1 0	TYPEC_RX1N	Receiver serial data -
B1 1	TYPEC_RX1P	Receiver serial data +		B1 2	GND	Ground

2.5 USB HOST (J12)



EM3576 provides one USB2.0.

The USB2.0 interfaces is designed to work with USB host as a high-speed hub. It is used to connect USB mouse, U disk, USB camera, and other USB devices. Support hot-plug.

Feature

- Supports high-speed (480Mbps), full-speed (12Mbps) and low-speed (1.5Mbps) mode
- Supports automatic switching between bus- and self-powered modes
- Provides 16 host mode channels
- Support periodic out channel in host mode

J12					
Pin	Signal	Description	Pin	Signal	Description
1	VCC5V0_DEVI CE_S0	5V power supply	2	USB2_OTG1_D M	USB data-
3	USB2_OTG1_D P	USB Data+	4	GND	Ground

Note:

USB2 OTG1 can only be used when PCIE1/SATA1 is not in use !!!

2.6 SATA (J6, J8)



The EM3576 SATA interface support a maximum data rate of 6Gbps.

J6(SATA)					
Pin	Signal	Description	Pin	Signal	Description
1	VCC5V0_DEVI CE_S0	5V power supply	2	USB2_OTG1_D M	USB data-
3	USB2_OTG1_D P	USB Data+	4	GND	Ground

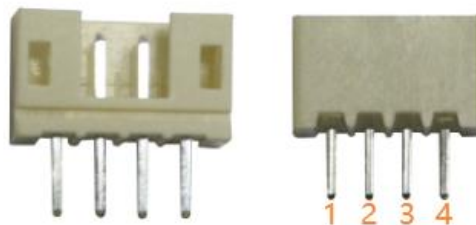

J8(SATA Power)					
Pin	Signal	Description	Pin	Signal	Description
1	VCC5V0_DEVI CE_S0	5V power supply	2	USB2_OTG1_D M	USB data-
3	USB2_OTG1_D P	USB Data+	4	GND	Ground

Note:

USB2 OTG1 cannot be used when PCIE1/SATA1 is in use !!!

2.7 Ethernet (JP1)

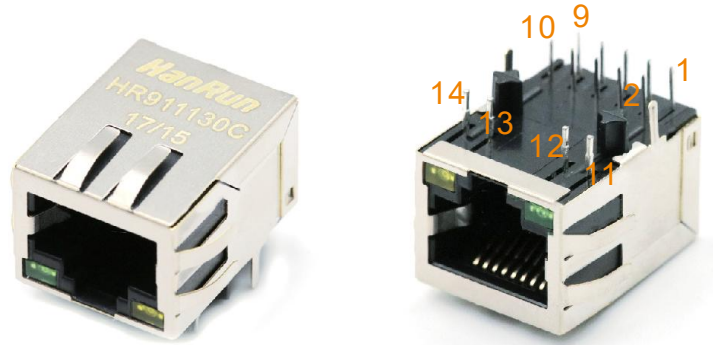

EM3576 adopts RTL8211F as the Ethernet chip. RJ45 connector.

Feature

- Supports 10/100/1000-Mbps data transfer rates with the RGMII interfaces.
- Supports both full-duplex and half-duplex operation.
- Supports IEEE 802.3ab.

Pin	Signal	Description	Pin	Signal	Description
1	COM	Common	2	PHY1_MDI 0+	Bi-directional transmit/receive pair 0
3	PHY1_MDI 0-	Bi-directional transmit/receive pair 0	4	PHY1_MDI 1+	Bi-directional transmit/receive pair 1
5	PHY1_MDI 2+	Bi-directional transmit/receive pair2	6	PHY1_MDI 2-	Bi-directional transmit/receive pair2
7	PHY1_MDI 1-	Bi-directional transmit/receive pair 1	8	PHY1_MDI 3+	Bi-directional transmit/receive pair 3
9	PHY1_MDI 3-	Bi-directional transmit/receive pair 3	10	AGND	Ground
11	GLEDA(VC C_3V3_S3)	3.3V	12	GLEDK (LINK1)	Detect link
13	YLEDK (GND)	Ground	14	YLEDA (SPEED1)	Detect speed
15	GND	Ground	16	GND	Ground

2.8 MIPI Panel (CON4)

EM3576 supports 10.1-inch MIPI Capacitive LCD, up to 1280 x 800 resolution.

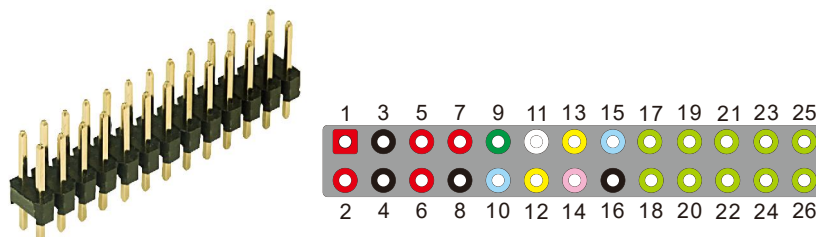

Pin	Signal	Description	Pin	Signal	Description
1	VCC5V0_DEVIC E_S0	5V power supply	2	VCC5V0_DEVI CE_S0	5V power supply
3	GND	Ground	4	GND	Ground
5	VCC_3V3_S3	3.3V power supply	6	VCC_3V3_S3	3.3V power supply
7	VCC_1V8_S3	1.8V power supply	8	GND	Ground
9	LCD_BL_PWM1 _CH1_M0	Backlight PWM output	10	GPIO0_B4_d	GPIO
11	NC	Not Connect	12	I2C0_SCL_M1 _TP	I2C serial clock line
13	I2C0_SDA_M1_ TP	I2C data line	14	TP_RST_L	Touch screen reset
15	TP_INT_L	GPIO	16	GND	Ground
17	MIPI_DPHY_DSI _TX_D0N	MIPI DSI negative differential data line transceiver output	18	MIPI_DPHY_D SI_TX_D0P	MIPI DSI positive differential data line transceiver output
19	MIP_DPHY_DSI _TX_D1N	MIPI DSI negative differential data line transceiver output	20	MIPI_DPHY_D SI_TX_D1P	MIPI DSI positive differential data line transceiver output
21	MIPI_DPHY_DSI _TX_CLKN	MIPI DSI negative differential clock line transceiver output	22	MIPI_DPHY_D SI_TX_CLKP	MIPI DSI positive differential clock line transceiver output
23	MIPI_DPHY_DSI _TX_D2N	MIPI DSI negative differential data line transceiver output	24	MIPI_DPHY_D SI_TX_D2P	MIPI DSI positive differential data line transceiver output
25	MIPI_DPHY_DSI _TX_D3N	MIPI DSI negative differential data line transceiver output	26	MIPI_DPHY_D SI_TX_D3P	MIPI DSI positive differential data line transceiver output

2.9 LCDC-RGB888 (J10: Option)



Pin	Signal	Description	Pin	Signal	Description
1	VCC5V0_DEVIC E_S0	5V power supply	2	VCC5V0_DEVI CE_S0	5V power supply
3	LCDC_D0	LDCC data0	4	LCDC_D1	LCDC data1
5	LCDC_D2	LCDC data2	6	LCDC_D3	LCDC data3

7	LCDC_D4	LCDC data4	8	LCDC_D5	LCDC data5
9	LCDC_D6	LCDC data6	10	LCDC_D7	LCDC data7
11	GND	Ground	12	LCDC_D8	LCDC data8
13	LCDC_D9	LCDC data9	14	LCDC_D10	LCDC data10
15	LCDC_D11	LCDC data11	16	LCDC_D12	LCDC data12
17	LCDC_D13	LCDC data13	18	LCDC_D14	LCDC data14
19	LCDC_D15	LCDC data15	20	GND	Ground
21	LCDC_D16	LCDC data16	22	LCDC_D17	LCDC data17
23	LCDC_D18	LCDC data18	24	LCDC_D19	LCDC data19
25	LCDC_D20	LCDC data20	26	LCDC_D21	LCDC data21
27	LCDC_D22	LCDC data22	28	LCDC_D23	LCDC data23
29	GND	Ground	30	LCD_PWM	PWM2_CH7_M0 (Backlight PWM output)
31	TOUCH_RST	Touch screen reset	32	GND	Ground
33	LCDC_DEN	valid data signal	34	LCDC_VSYNC	vertical sync signal
35	LCDC_HSYNC	Horizontal Synchronization Signal	36	LCDC_CLK	Pixel Clock Signal
37	GND	Ground	38	TSXP@TOUCH_H_INT	Touch INT
39	TSYM@TOUCH_SCL	Touch clock	40	TSYP@TOUCH_H_SDA	Touch Data

Note:

The TOUCH_RST, TSXP@TOUCH_INT, TSYM@TOUCH_SCL, TSYP@TOUCH_SDA multiplexing with CON4. The Software default support 10.1-inch MIPI capacitive LCD not support RGB-LCD.

2.10 GPIO (J9)



8pin connector. It is used to connect the gpio device.

Pin	Signal	Description	Pin	Signal	Description
-----	--------	-------------	-----	--------	-------------

1	VCC_3V3_S3	3.3V power supply	2	I2C2_SDA_M0_ CC_RTC	I2C2 data
3	I2C_SCL_M0_CC _RTC	I2C2 clock	4	GPIO4_A5_d	GPIO
5	GPIO4_A7_d	GPIO	6	GND	Ground
7	SPDIF_TX0_M1/ GPIO4_A1_d	GPIO	8	GND	Ground

2.11 Camera (J24, J25, J26, J27, J28, J29)

EM3576 supports connecting up to 12x AHD cameras.

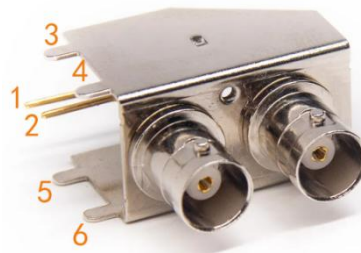

12x AHD Camera

Features

- High performance million CMOS image sensor Support 1280x 800@30fps and 1920x 1080@30 fps AHD camera.
- Module Interface BNC.
- High image color fidelity for realistic visuals.

J24					
Pin	Signal	Description	Pin	Signal	Description
1	TP2855-1_IN1	Ground	2	TP2855-1_IN2	Ground
3	GND	Ground	4	GND	Ground
5	GND	Ground	6	GND	Ground
J25					
Pin	Signal	Description	Pin	Signal	Description
1	TP2855-1_IN3	Ground	2	TP2855-1_IN4	Ground
3	GND	Ground	4	GND	Ground
5	GND	Ground	6	GND	Ground
J26					

Pin	Signal	Description	Pin	Signal	Description
1	TP2855-2_IN1	Ground	2	TP2855-2_IN2	Ground
3	GND	Ground	4	GND	Ground
5	GND	Ground	6	GND	Ground
J27					
Pin	Signal	Description	Pin	Signal	Description
1	TP2855-2_IN4	Ground	2	TP2855-2_IN3	Ground
3	GND	Ground	4	GND	Ground
5	GND	Ground	6	GND	Ground
J28					
Pin	Signal	Description	Pin	Signal	Description
1	TP2855-3_IN1	Ground	2	TP2855-3_IN2	Ground
3	GND	Ground	4	GND	Ground
5	GND	Ground	6	GND	Ground
J29					
Pin	Signal	Description	Pin	Signal	Description
1	TP2855-3_IN4	Ground	2	TP2855-3_IN3	Ground
3	GND	Ground	4	GND	Ground
5	GND	Ground	6	GND	Ground

2.12 UART (J1, J18, J19)

- UART0 with 2 wires for debug tools
- Embedded two 64byte FIFO
- Support auto flow control mode for UART10-11



The J1 is 3-pin connector. The debug serial port baud rate is 1500000.

Pin	Signal	Description	Pin	Signal	Description
1	UART0_RX_M0_DEBUG	Serial data input	2	UART0_TX_M0_DEBUG	Serial data output
3	GND	Ground			



The J18 J19 used for RS232.

J18					
Pin	Signal	Description	Pin	Signal	Description
1	VCC_3V3_S3	3.3V power supply	2	UART11_TX_M0	Transmit Data
3	UART11_RX_M0	Receive Data	4	GND	Ground
J19					
Pin	Signal	Description	Pin	Signal	Description
1	VCC_3V3_S3	3.3V power supply	2	UART10_TX_M0	Transmit Data
3	UART10_RX_M0	Receive Data	4	GND	Ground

2.13 RS485 (J52)

SP3485EN-L/TL Differential bus transceiver.

- Driver/Receiver Enable
- Allows up to 32 transceivers on the serial bus.
- Compatibility with industry standard 75176 pin out
- Driver Output Short-Circuit Protection
- +3.3V low power half-duplex transceiver

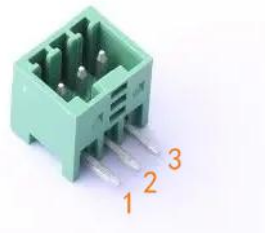

J32					
Pin	Signal	Description	Pin	Signal	Description
1	GND	Ground	2	RS485_A-1	RS-485 Data Line
3	RS485_B-1	RS-485 Data Line			

2.14 CAN (J15)

The CAN via TCAN1044VDRQ1 controller

- Support of classical CAN performance at 2, 5, and 8Mbps
- I/O voltage range supports 1.7V to 5.5V
- Support Normal mode and Low power standby mode

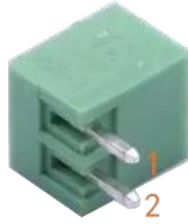

J32					
Pin	Signal	Description	Pin	Signal	Description
1	CANL-1	Low-level CAN bus input/output line	2	CANH-1	High-level CAN bus input/output line

2.15 Button (SW1, SW2, SW3)



SW1					
Pin	Signal	Description	Pin	Signal	Description
1	GND	Ground	2	RESET_L	RESET
SW2					
Pin	Signal	Description	Pin	Signal	Description
1	GND	Ground	2	PWRON_L	PWRON/OFF
SW3					
Pin	Signal	Description	Pin	Signal	Description
1	GND	Ground	2	RECOVERY_S ARADC_VIN1	RECOVER

2.16 Micro SD CARD (J3)

The Micro SD card is used as an external storage device. The MMC controller interface supports up to 4-bit transfer modes. MMC is always accessible through the carrier board interface.



Pin	Signal	Description	Pin	Signal	Description
1	SDMMC0_D2	SD/MMC data2	2	SDMMC0_D3	SD/MMC data3
3	SDMMC0_CMD	SD/MMC command signal	4	SD_3V3	3.3V
5	SDMMC0_CLK	SD/MMC clock	6	GND	Ground
7	SDMMC0_D0	SD/MMC data0	8	SDMMC0_D1	SD/MMC data1
9	SDMMC0_DET_L_1V8	SD/MMC detect signal			

2.17 WiFi&Bluetooth (U12)

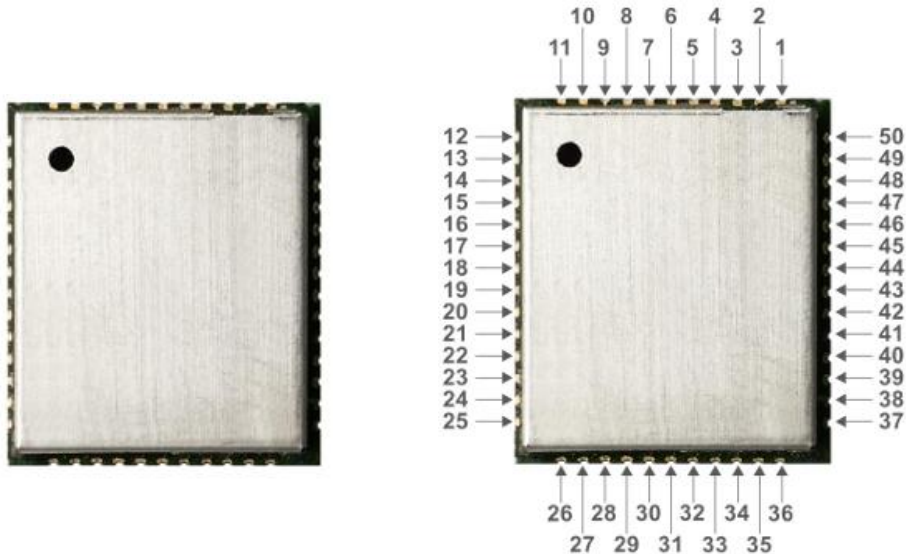

The LB-LINK BL-M8821BS1 is a highly integrated dual-band WLAN + BT41 2T2R SDIO module which has incorporated Wi-Fi and Bluetooth into one chip. The integrated module provides SDIO interface for WiFi, UART / PCM for Bluetooth.

RTL8723BS Module Specifications

Standard	IEEE 802.11a/b/g/n/ac, wireless data rate can reach up to 867Mbps
Host Interface	is SDIO3.0 (comply with SDIO1.1/2.0) and UART for BT
Frequency Range	2.4~2.4835GHz or 5.15~5.85GHz
Power Consumption	Standby 195mA (Max) TX mode 650 mA (Max)

Antenna	Connect to external antenna through half hole connector
Dimension	13.1*15.1*3.5mm (L*W*H), Tolerance: ±0.15mm
Working Temp.	-10°C to +70°C
Power supply	VDD 3.3V±0.2V

Pin	Signal	Description	Pin	Signal	Description
1	GND	Ground	2	WL/BT_ANT0	RF port 0 (Connect to IPEX)
3	GND	Ground	4	GND	Ground
5	GND	Ground	6	GND	Ground
7	GND	Ground	8	GND	Ground
9	WL_ANT1	RF port 1	10	GND	Ground
11	GND	Ground	12	NC/NC/PCIE_PR EST_L	BT antenna (Connect to IPEX)
13	XTAL_OUT	Connect to 37.4MHz Crystal oscillator X2	14	XTAL_IN	Connect to 37.4MHz Crystal oscillator X1
15	WIFI_REG_ON_ H_1V8	Low asserting reset for wifi	16	WIFI_WAKE_HO ST_H_1V8	WLAN to wake up HOST
17	SDMMC1_CMD _M0_1V8	SDIO command line (WIFI_CMD)	18	SDMMC1_CLK_ M0_1V8	SDIO clock line(WIFI_CLK)
19	SDMMC1_D3_ M0_1V8	SDIO data line3(WIFI_D3)	20	SDMMC1_D2_M 0_1V8	SDIO data line2(WIFI_D2)
21	SDMMC1_D0_ M0_1V8	SDIO data line0(WIFI_D0)	22	SDMMC1_D1_M 0_1V8	SDIO data line1(WIFI_D1)
23	GND	Ground	24	VCCIO_WL	SDIO_VSEL
25	VIN_LD0	Connect to inductor	26	VIN_LDO_OUT	Connect to inductor
27	SAI2_LRCK_M0 _1V8	PCM sync signal	28	SAI2_SDO_M0_ 1V8	PCM data input
29	SAI2_SDI_M0_ 1V8	PCM data output	30	SAI2_SCLK_M0 _1V8	PCM clock
31	32KOUT_RTC_ 1V8	External low power clock input (32.768KHz)	32	GND	Ground
33	NC	Not connect	34	VCCIO_WL	I/O Voltage supply input
35	NC	Not connect	36	VCC3V3_WL_V BAT	3.3V Main Power Supply
37	NC	Not connect	38	BT_REG_ON_H _1V8	Low asserting reset for Bluetooth
39	GND	Ground	40	UART4_RX_M1_ 1V8	Bluetooth UART interface
41	UART4_TX_M1	Bluetooth UART	42	UART4_CTSN_ _1V8	Bluetooth UART

	_1V8	interface		M1_1V8	interface
43	UART4_RTSN_M1_1V8	Bluetooth UART interface	44	NC	Not connect
45	NC	Not connect	46	NC	Not connect
47	GND	Ground	48	NC	Not connect
49	HOST_WAKE_BT_H_1V8	HOST wake up Bluetooth device	50	BT_WAKE_HOST_H_1V8	Bluetooth device to wake up HOST

2.18 SSD (J7)

M2_KEY_B_M_socket (PCIe) for NVMe SSD.

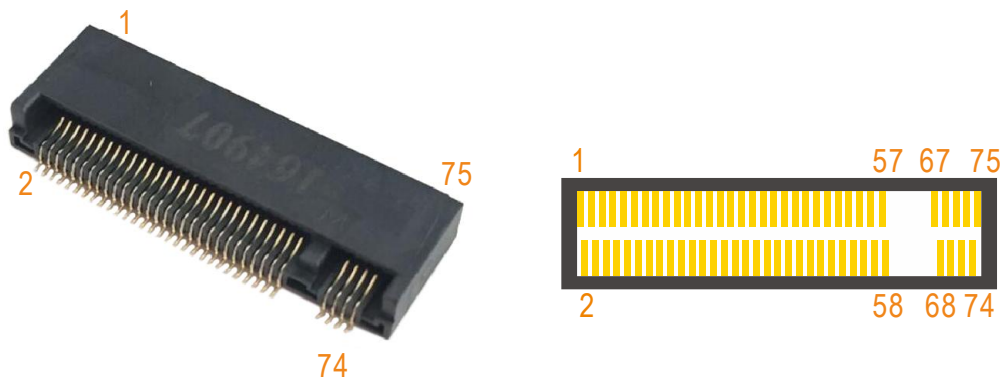

PCIe (for SSD module)					
Pin	Signal	Description	Pin	Signal	Description
1	GND	Ground	2	VCC3V3_M.2	3.3V power supply
3	GND	Ground	4	VCC3V3_M.2	3.3V power supply
5	NC	Not connect	6	NC	Not connect
7	NC	Not connect	8	NC	Not connect
9	NC	Not connect	10	NC	Not connect
11	NC	Not connect	20	NC	Not connect
21	GND	Ground	22	NC	Not connect
23	NC	Not connect	24	NC	Not connect
25	NC	Not connect	26	NC	Not connect
27	GND	Ground	28	NC	Not connect
29	NC	Not connect	30	NC	Not connect
31	NC	Not connect	32	NC	Not connect
33	GND	Ground	34	NC	Not connect
35	NC	Not connect	36	NC	Not connect
37	NC	Not connect	38	NC	Not connect
39	GND	Ground	40	NC	Not connect
41	PCIE0_RXN/SA TA0_RXN	PCIe data input -	42	NC	Not connect

43	PCIE0_RXP/SA TA0_RXP	PCle data input +	44	NC	Not connect
45	GND	Ground	46	NC	Not connect
47	PCIE0_TXN/SA TA0_TXN	PCle data output -	48	NC	Not connect
49	PCIE0_TXP/SA TA0_TXP	PCle data output +	50	PCIE0_PERS Tn	PCle global reset output (RC mode)
51	GND	Ground	52	PCIE0_CLKR EQn_M3	PCle reference clock request input (RC mode)
53	PCIE0_REFCLK N	PCle reference clock -	54	PCIE0_WAKE n_M0	PCle Wakeup Input (RC Mode)
55	PCIE0_REFCLK P	PCle reference clock +	56	NC	Not connect
57	GND	Ground	58	NC	Not connect
67	NC	Not connect	68	NC	Not connect
69	NC	Not connect	70	VCC3V3_M.2	3.3V power supply
71	GND	Ground	72	VCC3V3_M.2	3.3V power supply
73	GND	Ground	74	VCC3V3_M.2	3.3V power supply
75	GND	Ground	76	GND	Ground
77	GND	Ground	78	NC	Not connect
79	NC	Not connect	80	GND	Ground
81	GND	Ground	82	GND	Ground

2.19 SPI (J14)

The SPI is a 6-pin header connector.



Pin	Signal	Description	Pin	Signal	Description
1	VCC_3V3_S3	3.3V	2	SPI3_CLK_M1	Serial Clock
3	SPI3_MOSI_M1	Master Output Slave Input	4	SPI3_MISO_M1	Master Input Slave Output
5	SPI3_CSN1_M1	Chip Select/Slave Select	6	GND	Ground

2.20 NFC (J17)



Pin	Signal	Description	Pin	Signal	Description
1	SDA	Serial Data line	2	SCL	Serial Clock line
3	IRQ	Interrupt Request	4	VEN	Enable
5	5V	5V	6	3V3	3.3V
7	GND	Ground	8	NC	Not connect
9	NC	Not connect	10	NC	Not connect

Note:

The Software not support NFC.

2.21 RTC (J2)



The backup battery (3V) is used to ensure the RTC (frequency 32.768KHz) is still able to work after power off. Lithium cell model: CR1220.

Pin	Signal	Description	Pin	Signal	Description
1	VCC_RTC	3V battery	2	GND	Ground

3 Product Configurations

3.1 Standard Contents

NO.	Item	Qty. (PCS)	Description
1	EM3576 board	1	Standard Content (4GB RAM, 32GB eMMC)
2	U-Disk / CD-ROM	1	Android/ Debian/ Buildroot BSP, Documents, tools, Schematic Drawing, datasheets
3	Ethernet cable	1	1.5m Crossover cable
4	Serial Cable	1	CH9102X
5	USB Cable	1	USB Type_C Cable
6	Power adaptor	1	12V/3A DC
7	WIFI Antenna	3	WIFI Antenna

3.2 Optional Parts

- AHD Camera Module
- LCD Module (10.1-inch MIPI panel)
- 4G Module
- SSD
- SATA